

HCP1500 Series



- High Efficiency up to 90%
- High Power Density
- Programmable Output Voltage (30%–105%)
- Programmable Output Current (40%–105%)
- Parallel Operation
- Fully Featured Signals & Controls
- 3 Year Warranty

Specification

Input

Input Voltage	• 90-264 VAC (127-370 VDC), see derating curve
Input Frequency	• 47-63 Hz
Input Current	• 18.0 A/9.0 A typical at 115/230 VAC
Inrush Current	• 30.0 A/45.0 A typical at 115/230 VAC
Power Factor	• 0.99/0.98, typical at 115/230 VAC full load
Earth Leakage Current	• <1.0 mA at 240 VAC/60 Hz

Output

Output Voltage	• See model table
Output Trim	• $\pm 5.0\%$ by potentiometer
Output Voltage Program	• 30-105% of rated output
Output Current Program	• 40-105% of rated output
Initial Set Accuracy	• $\pm 1\%$
Minimum Load	• No minimum load required
Start Up Delay	• 1 s maximum
Start Up Rise Time	• 350 ms maximum at full load
Hold Up Time	• 16 ms typical at 230 VAC and full load
Line Regulation	• $\pm 0.5\%$
Load Regulation	• V1: $\pm 1\%$, 5 V standby output: $\pm 3\%$
Transient Response	• 1% max deviation for a 25% step load change
Ripple & Noise	• 150 mV pk-pk all voltages, see note 1
Overvoltage Protection	• Tracks output voltage. 115-125% of set voltage. Recycle AC to reset
Overtemperature Protection	• 90 °C, ± 5 °C measured on secondary heatsink. Output shuts down, auto recovers
Overload Protection	• 105-125% output shuts down, recycle AC to reset
Short Circuit Protection	• Output latches off, recycle AC to reset
Temperature Coefficient	• $\pm 0.02\%/^{\circ}\text{C}$ (0-50 °C)
Remote Sense Enable	• Compensates for 0.5 V max voltage drop • Output must be enabled. See application notes. Power supply is shipped with enable links fitted
Current Share	• 5 supplies can share within 5%
Standby Output	• 5 V at 0.5 A, present whenever AC is applied

General

Efficiency	• See model table
Isolation	• 3000 VAC Input to Output, 1500 VAC Input to Ground, 500 VDC Output to Ground
Isolation Resistance	• 100 M Ω /500 VDC
Switching Frequency	• PFC 100 kHz typical, PWM 65 kHz typical
Power Density	• 10.8 W/in ³
Signals & Controls	• Enable, Current Share, V Program, I Program, 5 V Standby, PWM switching
MTBF	• 100 kHrs to MIL-HDBK-217F at 25 °C

Environmental

Operating Temperature	• -25 °C to 60 °C, see derating curve
Cooling	• Internal fan fitted. Speed increases with load and internal temperature
Operating Humidity	• 20-90% R.H. non-condensing
Storage Temperature	• -40 °C to +85 °C
Storage Humidity	• 10-95% R.H.
Vibration	• 10-500 Hz, 5g 10 min/cycle, 60 min period for each axis. Compliant to IEC68-2-16, IEC 68-2-64

EMC & Safety

Emissions	• EN55022 class A conducted & radiated
Harmonic Currents	• EN61000-3-2 class A
Voltage Flicker	• EN61000-3-3
ESD Immunity	• EN61000-4-2, ± 4 kV contact, ± 8 kV air discharge, Perf Criteria A
Radiated Immunity	• EN61000-4-3, 10 V/m, Perf Criteria A
EFT/Burst	• EN61000-4-4, level 3, Perf Criteria A
Surge	• EN61000-4-5, installation class 3, Perf Criteria A
Conducted Immunity	• EN61000-4-6, 10 V, Perf Criteria A
Magnetic Field	• EN61000-4-8, 30 A/m, Perf Criteria A
Dips & Interruptions	• EN61000-4-11, 30% 10 ms, 60% 100 ms, >95% 5000 ms, Perf Criteria A, B, B
Safety Approvals	• UL60950-1, EN60950-1

Models and Ratings

Output Power	Output Voltage V1	OVP Range V1 ⁽²⁾	Output Current		Standby Output	Efficiency ⁽³⁾	Model Number
			Min	Max			
1500 W	12.0 VDC	13.80-15.00 V	0.0 A	125.0 A	5 V/0.5 A	87%	HCP1500PS12
1500 W	15.0 VDC	17.25-18.75 V	0.0 A	100.0 A	5 V/0.5 A	88%	HCP1500PS15
1500 W	24.0 VDC	27.40-30.00 V	0.0 A	62.5 A	5 V/0.5 A	89%	HCP1500PS24
1500 W	27.0 VDC	31.05-33.75 V	0.0 A	55.5 A	5 V/0.5 A	89%	HCP1500PS27
1500 W	48.0 VDC	55.20-60.00 V	0.0 A	31.3 A	5 V/0.5 A	90%	HCP1500PS48

Notes

1. Ripple & noise are measured with 20 MHz bandwidth and using 12" twisted pair-wire terminated with 0.1 μF & 47 μF capacitors in parallel.
2. Range given for nominal output voltage. OVP setting will track programmed output voltage.
3. Measured with 230 VAC input and full load.

Mechanical Details

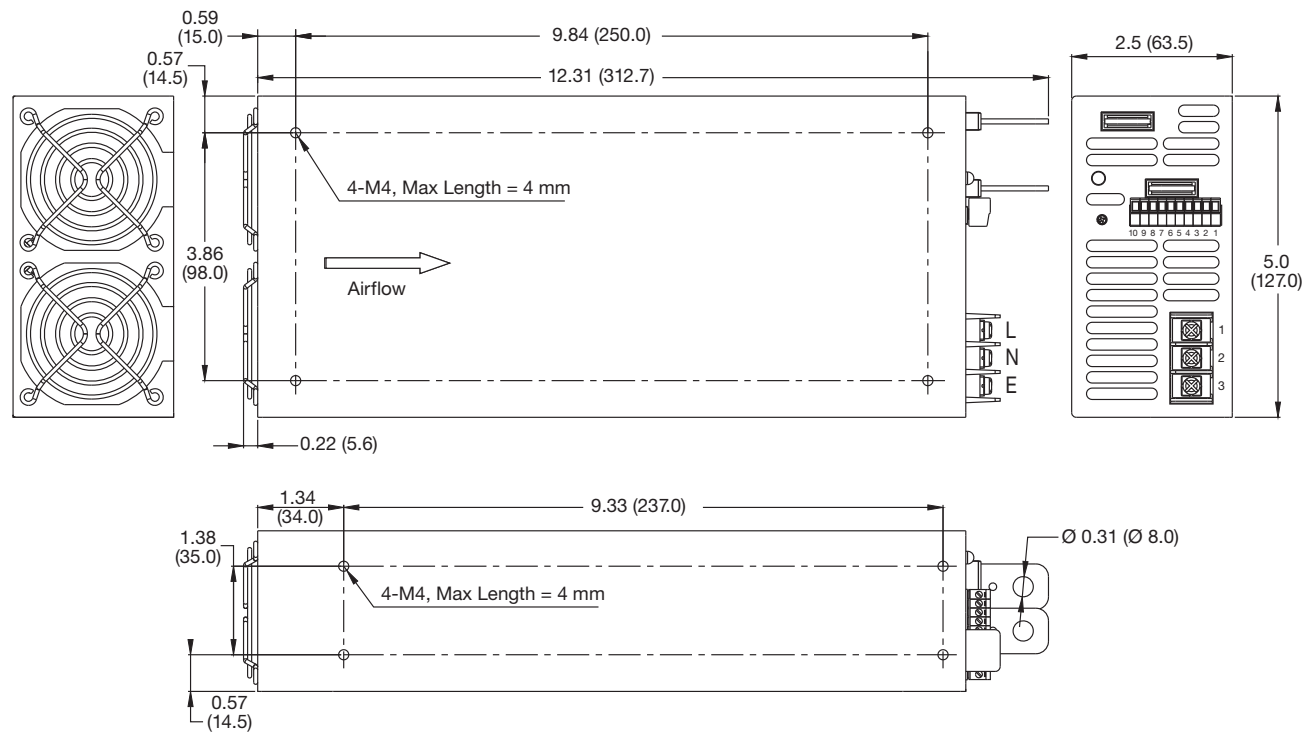

Notes

1. All dimensions are in inches (mm).
2. Weight 4.1 lb (1.9 kg)

Control Pin Connections					
Pin	Function	Description	Pin	Function	Description
1	VS+	Remote Sense (+)	6	GND	Signal Ground
2	VS-	Remote Sense (-)	7	PWM	PWM is Switching
3	5 V SB	5 V Standby Output (+)	8	VCI	V Program
4	EN+	Enable (+)	9	ACI	I Program
5	EN-	Enable (-)	10	CS	Current Share

Thermal Derating Curve

For HCP1500PS12/15

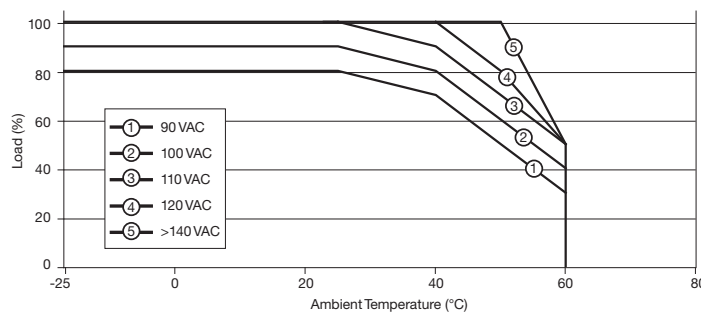

For HCP1500PS24/27/48

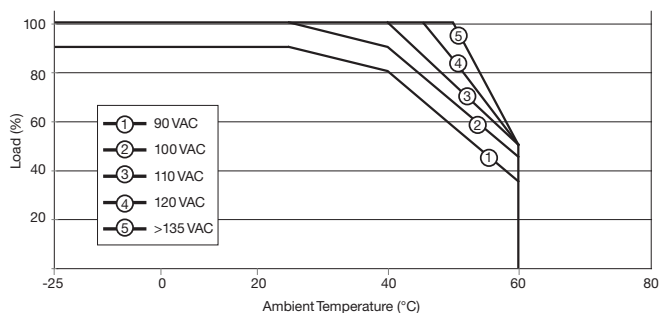

LED Status

LED Status	Output Status
Solid (Green)	DC Output OK
Slow Blink (Green)	Output Not Enabled
Fast Blink (Red)	Over Voltage
Solid (Red)	Over Loaded
	Short Circuited
	Under Voltage (<70% of output voltage)
Slow Blink (Red)	Over Temperature
Intermittent Blink (Red)	Fan Fail
Short & Long Blink (Red)	5 V Standby Failure

Output Voltage Program

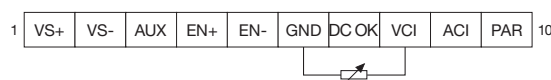
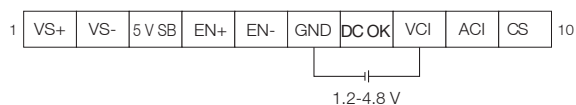
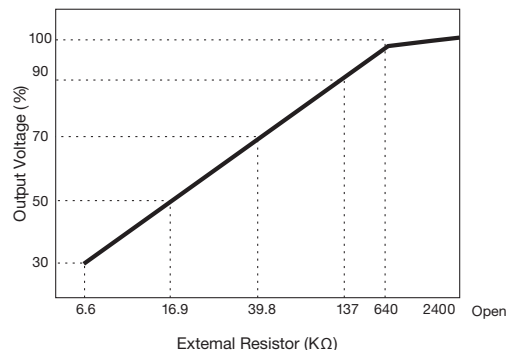
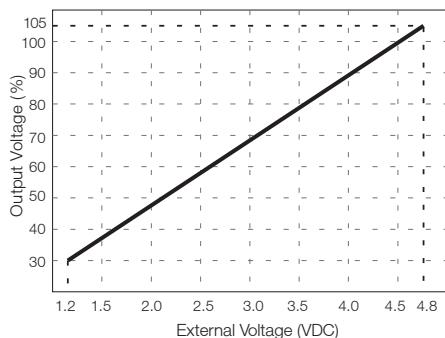

Output Current Program

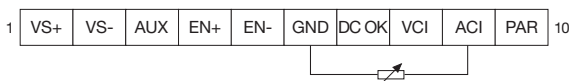
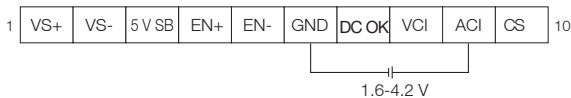
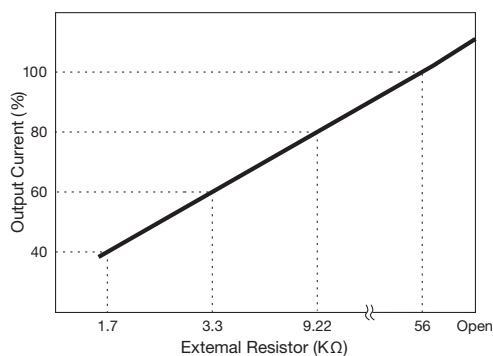
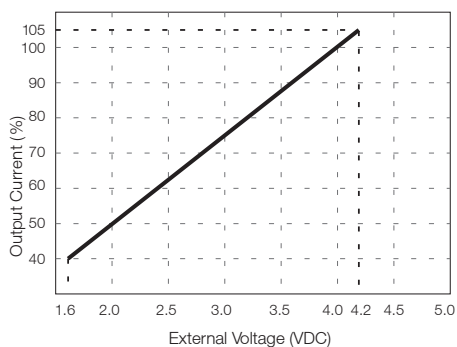

Remote Enable

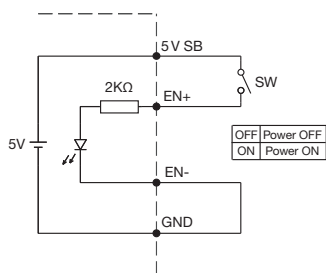

(A) Using internal 5V standby

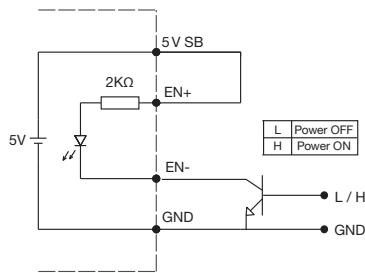

(B) Using external transistor

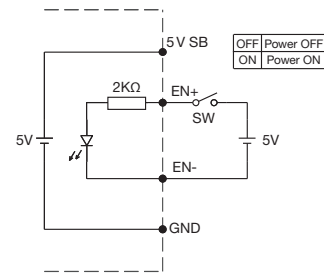

(C) Using external voltage source

PWM Signal

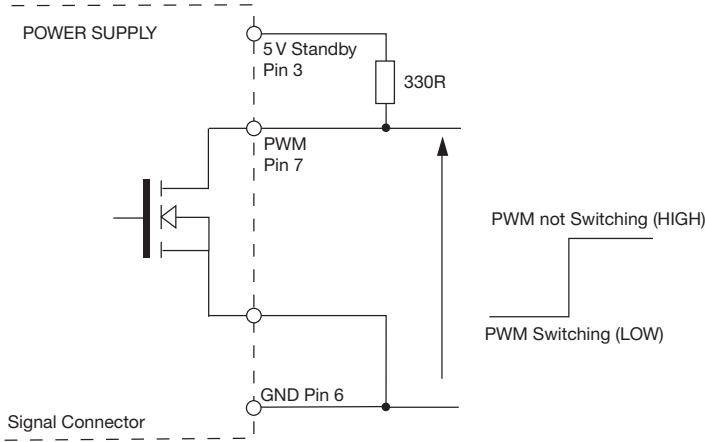

Open drain signal, low when PSU turns on
 Maximum sink current: 20 mA
 Maximum drain voltage: 40 V

Remote Sense

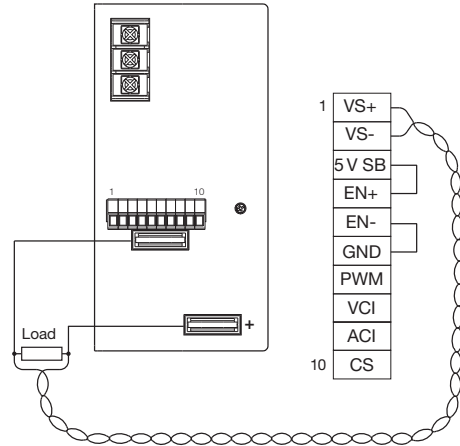

If remote sense is not required, connect VS+ and VS- locally to +VE and -VE terminals respectively

Current Share

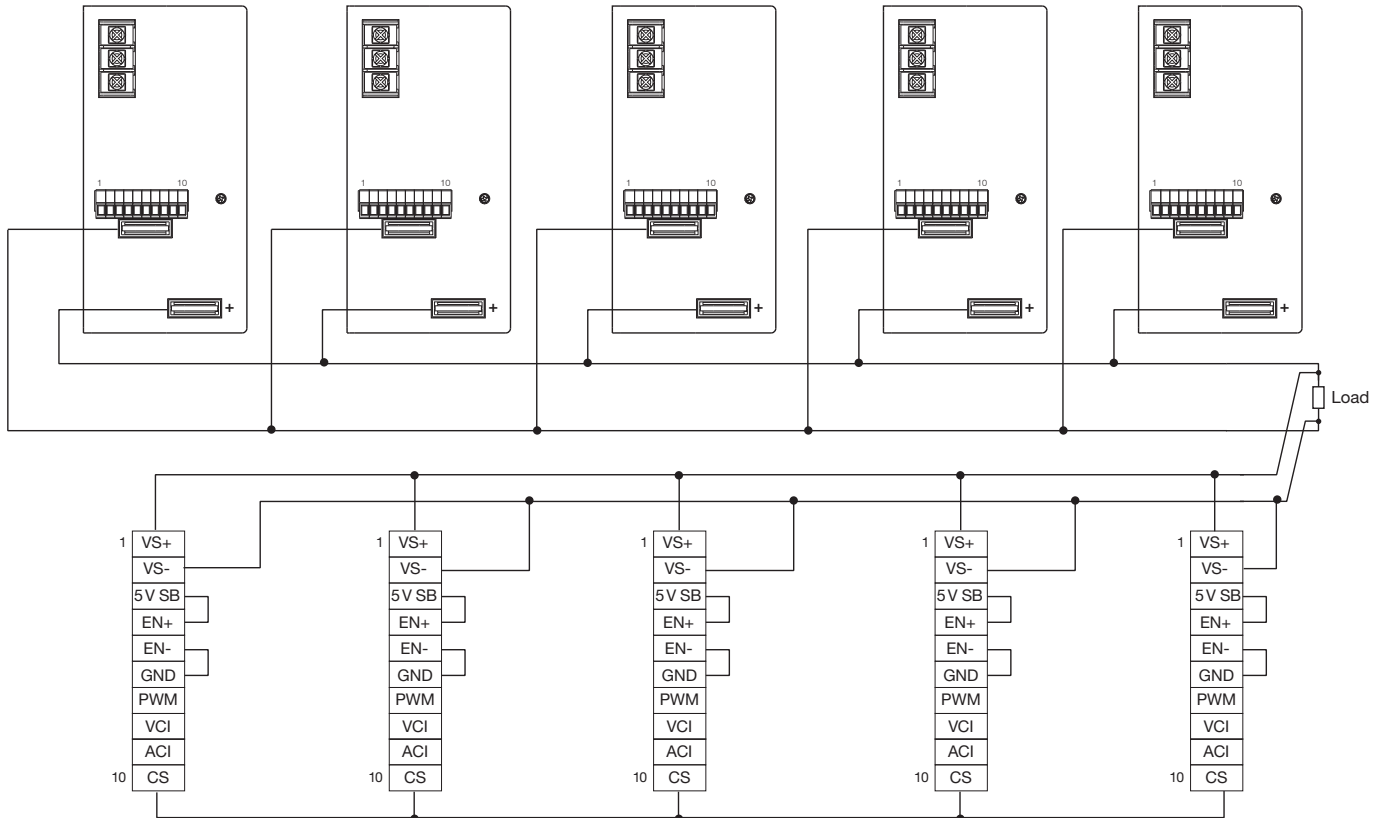

Notes

In parallel operation, it is possible that only one unit will operate if the load is less than 5% of the combined rated output load. It is possible to have more than five units in parallel, contact sales for details.