

80 Watts

- Ultra Compact Size
- Single Outputs from 12 to 48 V
- Encapsulated
- PCB, Chassis Mount and DIN Rail Versions
- <0.3 W No Load Input Power
- -40 to +70 °C Operation
- Peak Load Capability
- 3 Year Warranty



The ECE80 series of compact encapsulated AC-DC power modules are available in both PCB & chassis mount versions offering exceptional power density of >11W/in³. Output voltages are available from 12 – 48 VDC and these “green power” modules offer high active mode efficiency and low no load power consumption. They also provide a peak load capability up to 130% of nominal power for up to 30s and a wide operating temperature range from -40 to +70°C.

Dimensions:

ECE80:

3.60 x 1.80 x 1.10" (91.4 x 45.72 x 28.0 mm)

ECE80-S:

4.45 x 1.87 x 1.12" (113.0 x 47.5 x 28.5 mm)

Models & Ratings

Output Power	Output Voltage	Output Current		Efficiency ⁽⁴⁾	Model Number ^(2,3)
		Nominal	Peak ⁽¹⁾		
80 W	12.0 V	6.67 A	8.67 A	88%	ECE80US12
80 W	15.0 V	5.33 A	6.93 A	88%	ECE80US15
80 W	24.0 V	3.33 A	4.33 A	87%	ECE80US24
80 W	36.0 V	2.22 A	2.89 A	87%	ECE80US36
80 W	48.0 V	1.67 A	2.17 A	87%	ECE80US48

Notes

1. Peak load lasting <30 s with a maximum duty cycle of 10%, average output power not to exceed nominal power.
2. Add suffix -S to model number to denote chassis mount with screw terminal type, e.g. ECE80US12-S.
3. A screw terminal version (-S) is available with DIN Clip attached. Add suffix 'D', e.g. ECE80US24-SD. DIN Rail mounting clip is available as a separate item, order code ECE80 DIN CLIP.
4. Average of efficiencies measured at 25%, 50%, 75% & 100% load with 230 VAC input.

Summary

Characteristic	Minimum	Typical	Maximum	Units	Notes & Conditions
Input Range	85		264	VAC	Derate load from 100% at 90 VAC to 90% at 85 VAC
No Load Input Power			<0.3	W	12-36 V versions
			<0.5	W	48 V version
Efficiency	86	87	88	%	See note 4 above
Operating Temperature	-40		+70	°C	Some specification parameters may not met below -25 °C. Derate linearly from 100% load at +50 °C to 50% load at 70 °C.
EMC	EN55022 & 32 Level B Conducted & Radiated, EN61000-4, EN61000-3				
Safety Approvals	EN60950-1, UL60950-1, CSA22.2 No. 234 per cUL				

Input

Characteristic	Minimum	Typical	Maximum	Units	Notes & Conditions
Input Voltage - Operating	85		264	VAC	Derate load from 100% at 90 VAC to 90% at 85 VAC
Input Frequency	47		63	Hz	
Power Factor					EN61000-3-2 class A compliant
Input Current		1.4/0.87		A rms	At 115/230 VAC
No Load Input Power			0.3	W	12-36 V versions
			0.5	W	48 V version
Inrush Current		60/120		A	115/230 VAC cold start at 25 °C
Earth Leakage Current					Class II construction no earth
Input Protection	Internal T3.15 A/250 VAC fuse				

Output

Characteristic	Minimum	Typical	Maximum	Units	Notes & Conditions
Output Voltage	12		48	VDC	See Models and Ratings table
Initial Set Accuracy			1	%	At 100% load
Minimum Load	0			A	No minimum load required
Start Up Delay			0.5	s	
Start Up Rise Time			30	ms	
Hold Up Time	8.4	15		ms	At full load and 115 VAC
Line Regulation			±0.5	%	
Load Regulation			±1	%	
Transient Response			4	%	Recovery within 1% in less than 500 µs for a 25% load change
Ripple & Noise			1/2	% pk-pk	For ECE80/ECE80-S, 20 MHz bandwidth
Overvoltage Protection	115		140	% Vnom	
Overload Protection	110		185	%	
Short Circuit Protection					Trip & restart (hiccup mode)
Temperature Coefficient			0.02	%/°C	

General

Characteristic	Minimum	Typical	Maximum	Units	Notes & Conditions
Efficiency	86	87	88	%	See Models & Ratings table
Isolation	3000			VAC	Input to Output
Switching Frequency		65		kHz	
Power Density			11.2	W/in ³	
Mean Time Between Failure		>300		kHrs	MIL-HDBK-217F, +25 °C GB
Weight		0.66 (260)		lb (g)	ECE80
		0.71 (280)		lb (g)	ECE80-S

Environmental

Characteristic	Minimum	Typical	Maximum	Units	Notes & Conditions
Operating Temperature	-40		+70	°C	Some specification parameters may not met below -25 °C. Derate linearly from 100% load at +50 °C to 50% load at 70 °C.
Storage Temperature	-40		+85	°C	
Cooling					Convection-cooled
Humidity			95	%RH	Non-condensing
Operating Altitude			3048	m	
Vibration	2 g, 10 Hz to 500 Hz, 10 mins/cycle, 60 mins each cycle				

EMC: Emissions

Phenomenon	Standard	Test Level	Criteria	Notes & Conditions
Conducted	EN55022/55032	Class B		
Radiated	EN55022/55032	Class B		
Harmonic Current	EN61000-3-2			Class A
Voltage Flicker	EN61000-3-3			

EMC: Immunity

Phenomenon	Standard	Test Level	Criteria	Notes & Conditions
ESD	EN61000-4-2	± 6 kV/ ± 8 kV	A	Contact/Air Discharge
Radiated	EN61000-4-3	10 V/m 80% mod	A	
EFT	EN61000-4-4	3	A	
Surges	EN61000-4-5	2	A	
Conducted	EN61000-4-6	3	A	
Magnetic Fields	EN61000-4-8	3	A	
Dips and Interruptions	EN61000-4-11	DIP: >95% 10 ms DIP: 30% 500 ms INT: >95% 5000 ms	A A B	At 100 VAC and 230 VAC

Safety Approvals

Safety Agency	Safety Standard	Notes & Conditions
UL	UL60950-1, CSA 22.2 No.234 per cUL	
TUV	EN60950-1	
CB	IEC60950-1	

Mechanical Details

ECE80

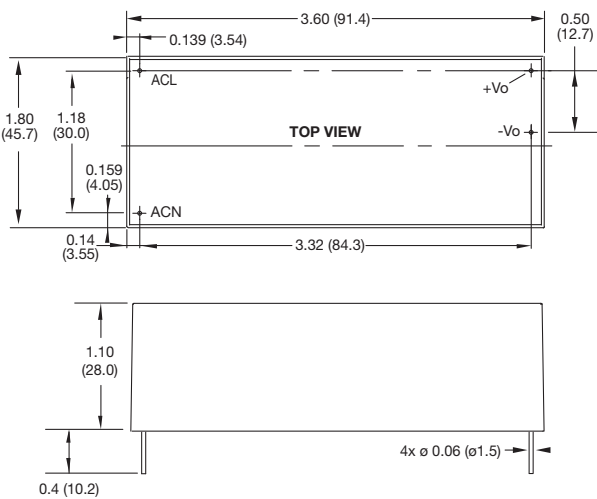

ECE80 Screw Terminal (-S)

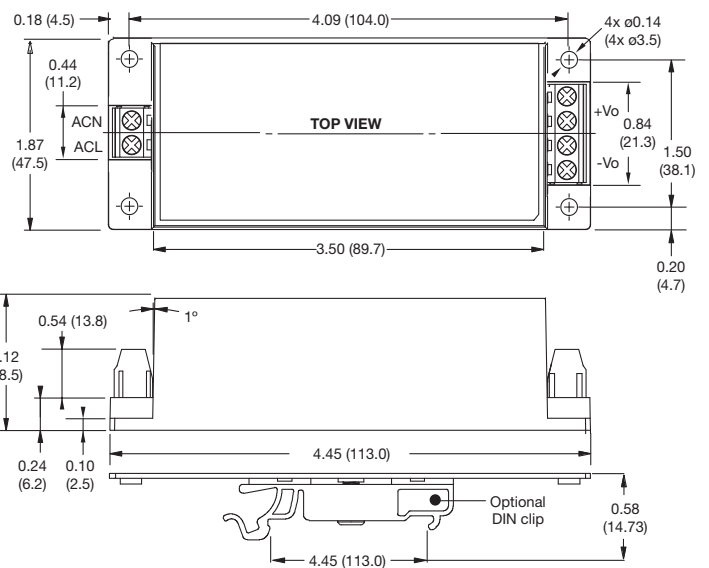

Notes

- All dimensions in inches (mm).
- Weight: ECE80: 0.66 lbs (260 g)
ECE80-S: 0.71 lbs (270 g)
- Tolerances: x.xx = ± 0.02 (x.x = ± 0.5), x.xxx = ± 0.01 (x.xx = ± 0.25)