



EL320.256 -F6 and -FD6 Operation Manual

Table of contents:

1	Product profile	3
2	TFEL technology.....	3
3	Electrical characteristics	4
3.1	Connector layout.....	4
3.2	Input connectors and programmable jumpers	5
3.3	Connectors.....	6
3.4	Control basics	6
3.5	Power input.....	6
4	Display features.....	7
4.1	Low power mode.....	7
4.2	Two-bits-parallel	7
4.3	Brightness control	7
4.4	Self-test.....	7
4.5	Input specifications	8
4.6	Timing characteristics	9
4.7	Setup and hold timing.....	10
5	Operational specifications.....	11
5.1	Environmental	11
5.2	Reliability	11
5.3	Safety.....	11
5.4	Electromagnetic compatibility	11
5.5	Optical.....	12
5.5.1	Display color	12
6	Mechanical characteristics	13
7	Installation and handling.....	15
8	Description of warranty	16
9	Easy to use	16
10	Ordering information	17
11	Support and service.....	17
12	RoHS II.....	17

1 Product profile

The EL320.256-F Series displays are low-power, rugged, electroluminescent (TFEL) displays, which replace the bulky CRT in control and instrument product designs. They feature an integral DC/DC converter, and their compact dimensions save space that allows addition of features or reduction in overall size. They are designed to function in extreme environments, and their crisp display is viewable under most lighting conditions at wide viewing angles. Their ease of installation reduces system integration costs.

The EL320.256-F6 and -FD6 are 320 columns by 256 row flat panel displays with a resolution of 80 dots per inch. The pixel aspect ratio is 1:1. The digital flat panel interface is designed to match the needs of most systems. The display may be driven at frame rates up to 75 Hz.

The EL320.256-F Series displays require +5 V and +11 V to +30 V (V_{cc1} , V_{cc2}) power and 4 basic signals to operate:

1. Video Data or pixel information (VID)
2. Video Clock, pixel clock, or dot clock (VCLK)
3. Horizontal Sync (HS)
4. Vertical Sync (VS)

2 TFEL technology

The display consists of an electroluminescent glass panel and two mounted circuit boards with control electronics.

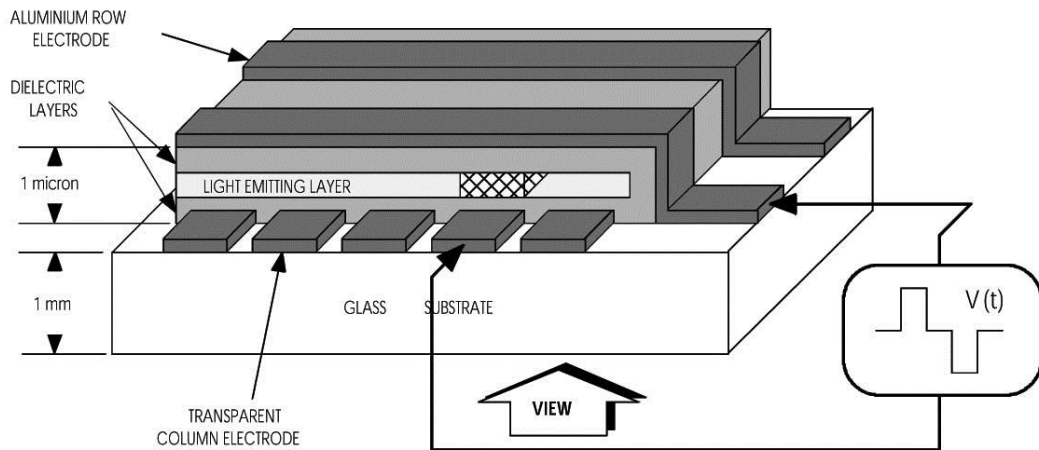

Figure 1. TFEL technology

The TFEL glass panel is a solid-state device with a thin film luminescent layer sandwiched between transparent dielectric layers and a matrix of row and column electrodes. The row electrodes, in back, are aluminums; the column electrodes, in front, are transparent. The entire thin film device is deposited on a single glass substrate. The glass panel is mounted to an electronic circuit assembly board (ECA) with an elastic spacer. The ECAs are connected to the TFEL glass panel with soldered lead frames. The result is a flat, compact, reliable, and rugged display device.

The EL320.256-FD6 display includes a dark ICEBrite™ (Integral Contrast Enhancement) background in the display glass. The ICEBrite background significantly improves the luminance contrast of the display in bright ambient. ICEBrite also removes the halo around the lit pixels in dark ambient, making the appearance of each pixel crisp and clear.

In the EL320.256-F Series, the 320 column electrodes and 256 row electrodes are arranged in an X-Y formation with the intersecting areas performing as pixels. Voltage is applied to both the correct row electrode and the correct column electrode to cause a lit pixel. Operating voltages required are provided by an integral DC/DC converter.

3 Electrical characteristics

3.1 Connector layout

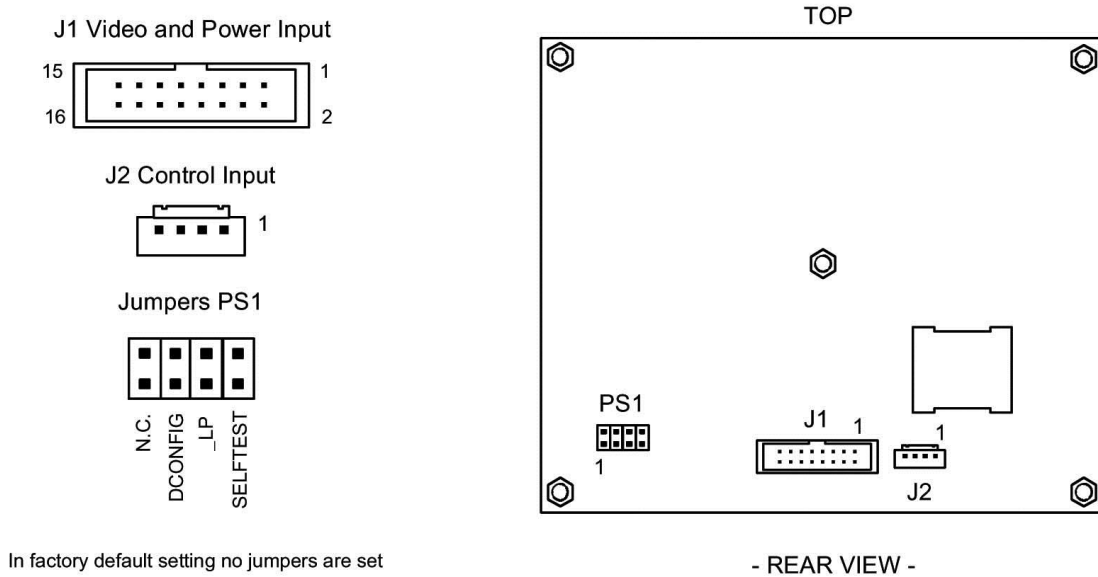

Figure 2. Input connectors and programmable jumpers

3.2 Input connectors and programmable jumpers

Table 1. Input connectors and programmable jumpers

Pins	Signal	Symbol	Description
J1(Data/power input connector)			
1, 2	Voltage	V _{cc2}	Supply voltage (+11 V... 30 V) converted to required internal high voltages.
3, 4	Voltage	V _{cc1}	Supply voltage (+5 V) for the logic.
5	Enable	_ENABLE	Display operation is enabled when LOW or left is disconnected.
6, 8, 10			
12, 14, 16	Ground	GND	Signal and power return.
7	Two-bit data	TVID	Odd column data input for optional two-bit parallel mode. See page 6.
9	Vertical Sync	VS	The vertical sync signal VS controls the vertical position of the picture. The topmost row displayed is the first HS HIGH time ending after the rising edge of the VS.
11	Horizontal Sync	HS	The horizontal sync signal HS controls the horizontal position of the picture. The last 320 pixels before the fall of HS are displayed.
13	Video Clock	VCLK	The VCLK signal shifts data present on the VID and TVID lines into the display system. VCLK is active on the rising edge.
15	Video Data	VID	Signal that supplies the pixel information to the system. Even pixel data for two-bit parallel mode. See page 6.
J2 (Control input)			
1	Luminance	LCa	Brightness control inputs a and b. If left disconnected, luminance is at its maximum level. See brightness control on page 7.
2	Luminance	LCb	
3	Ground	GND	Signal return. Same as GND in connector J1.

Pins	Signal	Symbol	Description
4	Low Power	_LOWPOW	If pulled LOW, the display is in Low Power Mode. The display has its normal brightness if HIGH or left disconnected. See page 6.
Pinstrip PS1			
1		NC	No connection.
2	Two-bit parallel	DCONFIG	The video data is input two pixels per video clock using VID and TVID if jumper is set.
3	Low Power	_LP	Low Power Mode is selected when jumper is set. This function overrides the _LOWPOW control input.
4	SELFTTEST		When set, video data input in VID and TVID is displayed asynchronously.

3.3 Connectors

Table 2. Connectors

J1	16-pin header	ODU 511.066.003.016 or eq.
	Mating	ODU 517.065.003.016 or eq.
J2	4-pin header	Hirose DF1-4P-2.5 DSA or eq.
	Mating	Hirose DF1-4S-2.5 R 24 or eq.
	Protector	Hirose DF1-4A 1.33

3.4 Control basics

The TFEL panel has 320 transparent column electrodes crossing 256 row electrodes in an X-Y fashion. Light is emitted when an AC voltage is applied at a row-column intersection. The display operation is based on the symmetric, line-at-a-time data addressing scheme, which is synchronized by the external VS, HS, and video clock input signals. The signal inputs are HCT-compatible with 100 Ω series resistors.

3.5 Power input

The input voltages needed are the +5 V input (V_{cc1}) for the logic and the +11 V... +30 V input (V_{cc2}) for the DC/DC converter generating all internal high voltages.

4 Display features

4.1 Low power mode

The power consumption of the display is possible to be reduced typically to 3 W by using the low power mode. This mode is selected either with the `_LP` jumper (PS1/3) or temporarily with the `_LOWPOW` control input (J2/4). The `_LP` jumper overrules the control input.

Low power mode is selected when the `_LP` jumper is set or the `_LOWPOW` input is pulled LOW. When `_LP` is open and `_LOWPOW` is HIGH or left disconnected, the display has its normal brightness. This function slightly reduces the contrast and average brightness of the display.

4.2 Two-bits-parallel

For reduction of data clock frequency, it is possible to input the data of two pixels per pixel clock. This feature is selected with the `DCONFIG` jumper (PS1/2). If the jumper is set, data for even columns is input in VID and data for odd columns is input in TVID. If the jumper is open, data is input normally to VID only.

4.3 Brightness control

The brightness of the display can be adjusted from below 10% up to full brightness by a 50 k Ω external logarithmic potentiometer between the LCa and LCb control inputs (J2/1 and /2). The control function is achieved by sinking a small current from LCa to LCb (when open, the voltages are at 5 V and 0 V respectively).

If the two inputs are left disconnected, the brightness is at its maximum level.

4.4 Self-test

The operation of the display can be easily tested using the two self-test features.

When the `SELFEST` jumper (PS1/4) is set, the video data at VID and TVID are displayed asynchronously without the use of any timing signals.

When only supply voltages without any video data are input, the display starts scanning with all pixels except the leftmost half of the topmost row on.

4.5 Input specifications

Table 3. Input specifications

Parameter	Symbol	Min.	Typ.	Max.	Absolute min./max.
Logic input HIGH		2.0 V	—	V_{cc1}	$V_{cc1} + 0.5$ V abs. max.
Logic input LOW			—	0.8 V	-0.5 V abs. min.
Supply voltage	V_{cc1}	4.75 V	5.0 V	5.25 V	6.0 V abs. max.
Supply current at 5 V	I_{cc1}	—	0.1 A	0.2 A	
Supply voltage	V_{cc2}	10.8 V	—	30 V	33 V abs. max.
Supply current at 12 V	I_{cc2}	—	0.3 A	0.6 A	
Supply current at 12 V (Low Power)	I_{cc2}	—	0.2 A	0.4 A	
Power consumption			4 W	8.2 W	
Power consumption (Low Power)			3 W	5 W	

Operating conditions: Ambient temperature 25 °C @ 60 Hz

NOTE: Absolute maximum ratings are those values beyond which damage to the device may occur. The minimum and maximum specifications in this Operation Manual should be met, without exception, to ensure the long-term reliability of the display. Beneq does not recommend operation of the display outside these specifications.

4.6 Timing characteristics

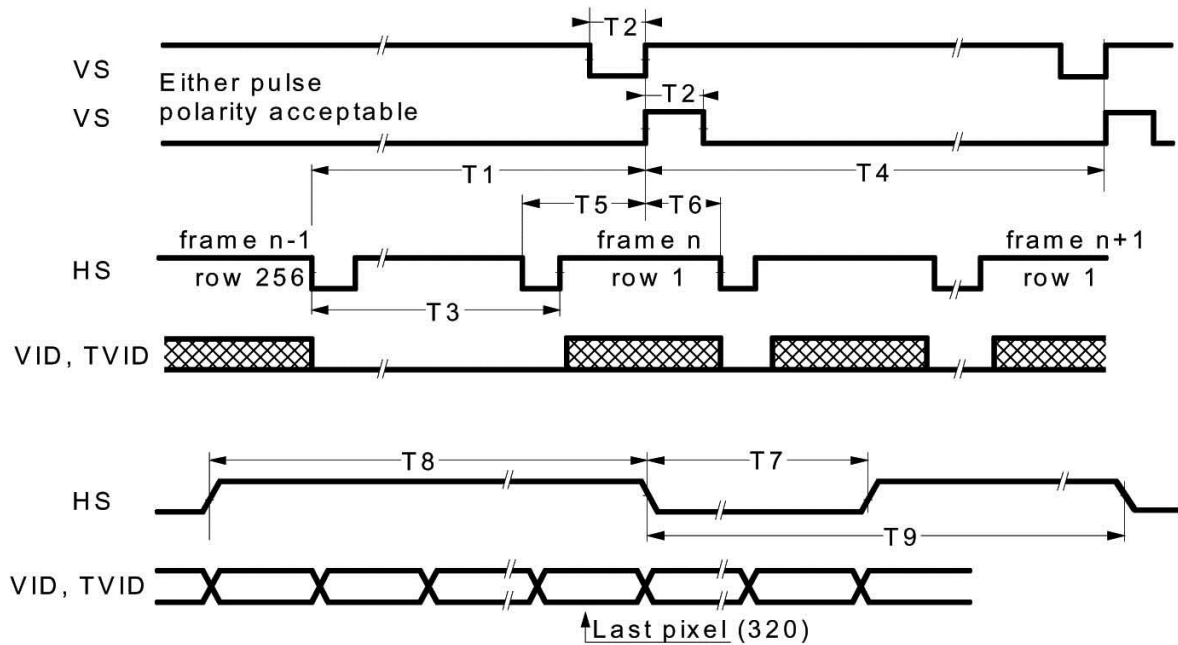

Figure 3. Timing characteristics

Table 4. Timing characteristics

Description	Min	Max	Unit	Note
T1 Vertical Front Porch	100		μs	1
T2 VS HIGH/LOW time	30		ns	2
T3 Vertical Blank	70		μs	
T4 Vertical Period	256		tHS	
VS frequency		75	Hz	
Description	Min	Typ	Unit	Note
T5 HS setup to VS	1		μs	3
T6 HS hold from VS	3		μs	
T7 HS Low Time	4		tVCLK	
T8 HS High Time	320	320	tVCLK	4
T9 HS period (tHS)	51		μs	

Notes:

1. This time is needed to display the last row and to initiate the following frame.
2. Only rising edge is used.
3. 2 tVCLK minimum.
4. The number of VCLK pulses during HS high time must be even. Video clock VCLK must be kept running continuously.

4.7 Setup and hold timing

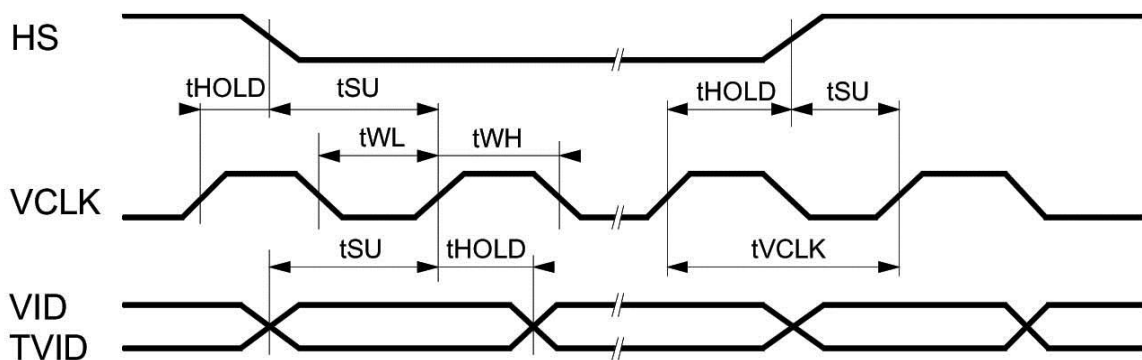

Figure 4. Setup and hold timing

Table 5. Setup and hold timing

Symbol	Description	Min	Max
tSU	HS, VID, TVID setup to VCLK	5 ns	
tHOLD	HS, VID, TVID hold from VCLK	8 ns	
tWL	VCLK low width	16 ns	
tWH	VCLK high width	16 ns	
tVCLK	VCLK period	40 ns	
	VCLK frequency		25 MHz

5 Operational specifications

5.1 Environmental

Table 6. Environmental characteristics

Temperature	
Operating	-25 °C...+65 °C
Non-operating	-40 °C...+85 °C
Operating survival	-40 °C...+70 °C (no permanent damage)
Humidity	
Relative humidity	+40 °C, 93% RH, operating (IEC 68-2-3)
Damp heat	+25 °C...+55 °C, 95% RH, non-operating (IEC 68-2-30)
Altitude	
	15,000 m (50,000 ft.) above sea level Standard IEC 68-2-13
Vibration	
	20...500 Hz ASD level 0.05 g ² /Hz 30 min each axis Standard IEC 68-2-36, Random Vibration, Test Fdb
Shock	
Magnitude	100 g
Duration	4 ms (half sine wave)
Number of shocks	18 (3 on each of the 6 surfaces) IEC 68-2-27, test Ea

5.2 Reliability

MTBF > 50,000 h @ 25 °C

5.3 Safety

The display will not inhibit the end product from obtaining any of the following certifications: UL544, IEC 601.

5.4 Electromagnetic compatibility

The display is capable of operating in an end product that complies with: EN55022 Class B, FCC Part 15J Class B.

5.5 Optical

Determined at 60 Hz frame rate at 25 °C ambient.

5.5.1 Display color

Wide band amber (ZnS:Mn) Peak wavelength 580 nm typ.

Table 7. Optical characteristics

Areal luminance		
On Luminance (typ)	-F6	77 cd/m ² (22.4 fL)
	-FD6	25 cd/m ² (7.3 fL)
On Luminance (min.)	-F6	55 cd/m ² (16.0 fL)
	-FD6	22 cd/m ² (6.4 fL)
Low power (min.)	-F6	45 cd/m ² (13.1 fL)
	-FD6	18 cd/m ² (5.2 fL)
Measured at the center and the four corners of the screen.		
Luminance non-uniformity		
	20% max.	
Low Power	26% max.	= (1- min. luminance/max luminance) x 100. Maximum difference between any two of five points (center and four corners)
Luminance variation (time)		
Maximum	10%	15,000 h @ 25 °C
Luminance variation (temperature)		
Maximum	15%	Over -25 °C ...+65 °C range.
Luminance contrast ratio		
-FD6	12:1 typ.	@ 500 lx
	3:1 typ.	@ 3,000 lx
Viewing angle		
	179°	

Illuminance	Classification
100 ... 1000 lx	Office
1000 ... 10000 lx	Bright
10000 ... 100000 lx	Sunlight

6 Mechanical characteristics

Table 8 shows the mechanical dimensions of a standard EL320.256-F6 and -FD6 display unit.

Table 8. Display external dimensions

Height	110 mm	4.33 in.
Width	130 mm	5.12 in.
Depth	31.0 mm	1.22 in.
Weight	260 g max.	9.2 oz.

The EL320.256-F6 and -FD6 are mechanically compatible with other Beneq MD320.256 and EL320.256 displays.

Table 9. Display viewing area characteristics

Active area		
millimeters (inches)	height	76.7 (3.02)
	width	95.9 (3.77)
Pixel pitch		
millimeters (inches)	height	0.30 (0.012)
	width	0.30 (0.012)
Pixel size		
millimeters (inches)	height	0.30 (0.012)
	width	0.30 (0.012)
Pixel fill factor	49%	
Pixel matrix	320 horizontal by 256 vertical	

CAUTION: The ambient temperature of the display should not be allowed to exceed the environmental specifications (see page 9). In most applications, an air gap of a minimum of 5 mm is recommended (see mechanical drawings). Some applications may require, however, a larger air gap or cooling of the display unit in the system. Note that this may slightly increase the total depth of the design.

CAUTION: In order to ensure mechanical compatibility with future revisions of the display, it is highly recommended not to intrude in the component envelope by any part of the customer application.

WARNING: The product generates potentially dangerous voltages capable of causing personal injury (high voltage pulses up to 195 V_{ac}). Do not touch the display electronics during operation!

ELECTROSTATIC CAUTION: The Beneq display uses CMOS and power MOS-FET devices. These components are electrostatic-sensitive. Unpack, assemble and examine this assembly

in a static-controlled area only. When shipping, use packing materials designed for protection of electrostatic-sensitive components.

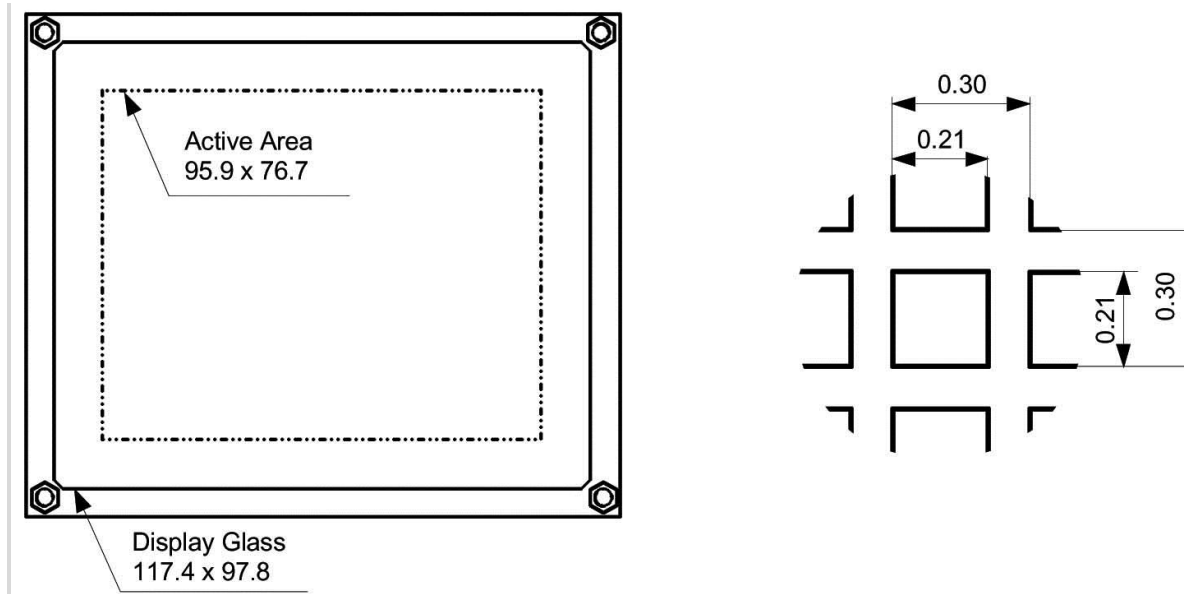

Figure 5. EL320.256-F6 and -FD6 display viewing area characteristics

7 Installation and handling

The product should be mounted using the M3 insert nuts on the ECA. Beside the four corner nuts, it is recommended to use also the center nut in the mounting if the vibration or shock stress is severe.

Before touching the display, necessary precaution must be taken to prevent application of static charges on the display from the operator or tools.

The display is made of glass material and should be handled with proper care. Do not drop the display or allow hard objects to strike its surface.

NOTE: For trouble-free data transfer, a maximum cable length of 300 mm (12 in.) from data transmitter to display input connector is recommended. If longer cables up to 2 m (80 in.) length are needed, a serial resistor of approximately 100 Ω could be placed at each of the four signal line outputs of the transmitter in order to lower signal reflections.

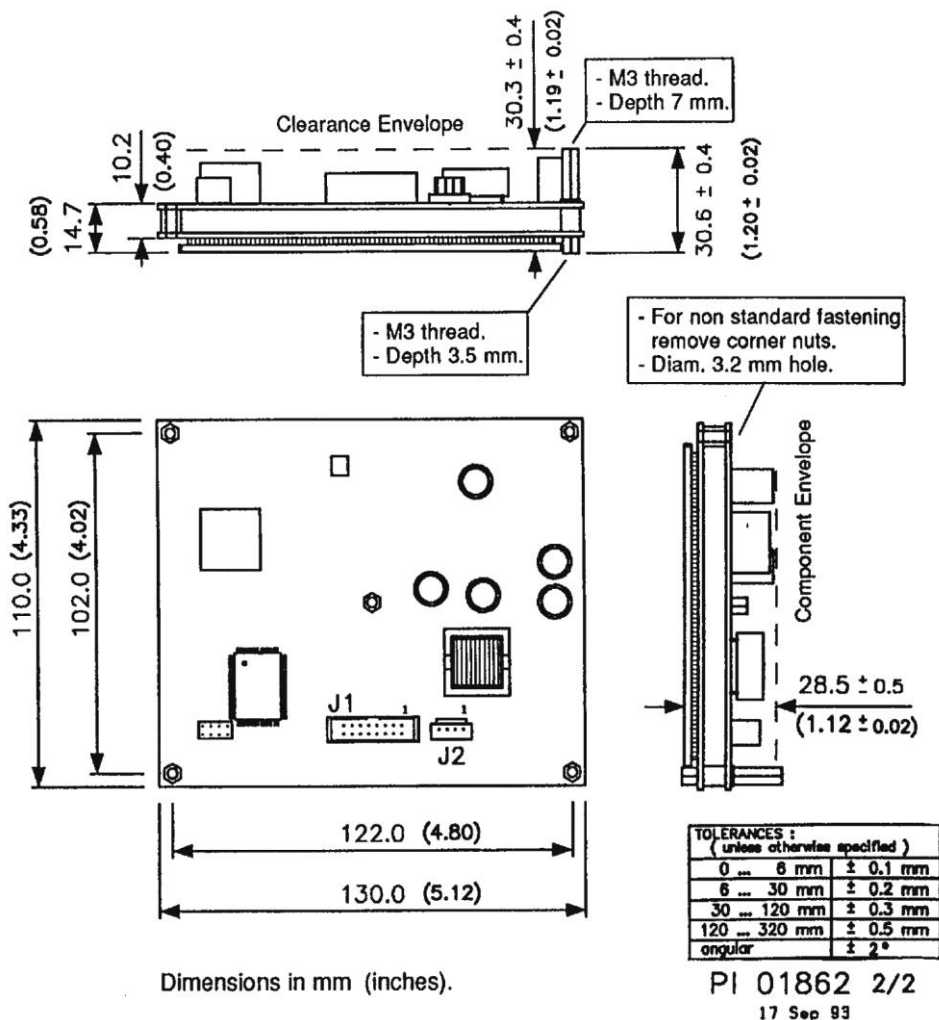

Figure 6. EL320.256-F6 and -FD6 display mechanical dimensions

8 Description of warranty

Seller warrants that the Goods will conform to published specifications and be free from defects in material during warranty time from delivery. To the extent that goods incorporate third-party-owned software, seller shall pass on seller's licensor's warranty to buyer subject to the terms and conditions of seller's license.

Warranty repairs shall be warranted for the remainder of the original warranty period. Buyer shall report defect claims in writing to seller immediately upon discovery, and in any event, within the warranty period. Buyer must return goods to seller within 30 days of seller's receipt of a warranty claim notice and only after receiving seller's return goods authorization. Seller shall, at its sole option, repair or replace the goods.

If goods were repaired, altered or modified by persons other than seller, this warranty is void. Conditions resulting from normal wear and tear and buyer's failure to properly store, install, operate, handle or maintain the goods are not within this warranty. Repair or replacement of goods is seller's sole obligation and buyer's exclusive remedy for all claims of defects. If that remedy is adjudicated insufficient, Seller shall refund buyer's paid price for the goods and have no other liability to buyer.

All warranty repairs must be performed at seller's authorized service center using parts approved by seller. Buyer shall pay costs of sending goods to seller on a warranty claim and seller shall pay costs of returning goods to buyer. The turnaround time on repairs will usually be 30 working days or less. Seller accepts no added liability for additional days for repair or replacement.

If seller offers technical support relating to the goods, such support shall neither modify the warranty nor create an obligation of seller. Buyer is not relying on seller's skill or judgment to select goods for buyer's purposes. Seller's software, if included with goods, is sold as is, and this warranty is inapplicable to such software.

SELLER DISCLAIMS ALL OTHER WARRANTIES, EXPRESS OR IMPLIED, INCLUDING BUT NOT LIMITED TO, IMPLIED WARRANTIES OF MERCHANTABILITY AND FITNESS FOR A PARTICULAR PURPOSE.

9 Easy to use

There are many options available, which make Beneq flat panel displays easy to use, easy to interface, and easy to package. Call Beneq for complete information.

10 Ordering information

Product	Part number	Description
EL320.256-F6	996-5076-00LF	
EL320.256-FD6	996-5087-00LF	ICE display

Design and specifications are subject to change without notice.

11 Support and service

Beneq Products is a Finnish company based in Espoo, Finland, with a world-wide sales distribution network. Full application engineering support and service are available to make the integration of Lumineq® displays as simple and quick as possible for our customers.

RMA Procedure: For a Returned Material Authorization number, please contact Beneq Products Oy by email (rma.lumineq@beneq.com) with the model number(s), serial number(s) and brief description of the problem. When returning goods for repair, please include a brief description of the problem, and mark the outside of the shipping container with the RMA number.

12 RoHS II

Beneq Products OY is committed to continuous improvement. As part of this process we are fully in support of EU directive 2011/65/EU, the Restriction of Hazardous Substances, commonly known as RoHS II or RoHS Recast, which, compared to RoHS, keeps the restrictions on the original six hazardous substances, including lead (Pb) in electronic equipment. It also expands these restrictions to previously exempted categories including medical devices and monitoring and control instruments.

Beneq part number with an "LF" suffix designation indicates RoHS compliance, as shown on the part number label affixed to the display and on the box containing the display.

This document is compiled and kept up-to-date as conscientiously as possible. Beneq cannot, however, guarantee that the data are free of errors, accurate or complete and, therefore, assumes no liability for loss or damage of any kind incurred directly or indirectly through the use of this document. The information in this document is subject to change without notice. All texts, pictures, graphics and any other contents of this document and their layout are protected by copyright and other protective laws. The aforementioned contents may not be duplicated, modified or used in other electronic or printed publications without the prior consent of Beneq. Unless otherwise stated, all trademarks are protected under trademark laws, especially the Beneq trademarks, logos, emblems and nameplates. The patents and trademarks presented in this document are the intellectual property of Beneq Oy. Beneq and Lumineq are registered trademarks of Beneq Oy. ICEBrite is a trademark of Beneq Oy.