



EL640.200-SK
ICEBrite™ Half-VGA Display

USER'S MANUAL

www.planar.com

Revision Control

Date	Description
July 2000	Document number OM250-01
June 2004	Document number 020-0348-00A
June 2005	Document number 020-0348-00B

Contents

EL640.200-SK Display	3
Features and Benefits	3
Installation and Handling.....	4
Mounting EL Displays	4
Cable Length.....	4
Cleaning	5
Avoiding Burn-In	5
Specifications	6
Control Basics	6
Power.....	6
Connector	8
Interface Information.....	9
<i>Buffered Video Mode</i>	9
<i>Non-buffered Video Mode</i>	9
Video Input Signals.....	10
Video Data in Non-Buffered Mode.....	11
Video Data in Buffered Mode.....	11
Dimming	12
<i>Analog Luminance Control</i>	12
Self-Test Mode.....	13
Optical.....	13
Environmental.....	14
Reliability.....	15
Safety and EMI Performance	15
Mechanical Characteristics	15
Component Envelope	15
Description of Warranty	17
Ordering Information	17
Support and Service.....	18

Figures

Figure 1. EL640.200-SK Power Curve	7
Figure 2. Data/Power Connector	8
Figure 3. Video Input Timing Diagram.	10
Figure 4. Pixel Location versus Sequence of Data in Non-buffered Mode.	11
Figure 5. Pixel Location versus Sequence of Data in Buffered Mode.	11
Figure 6. Display Dimensions.....	16

Tables

Table 1. DC Input Voltage Requirements.	6
Table 2. Video Input Requirements.	6
Table 3. Power Consumption.....	7
Table 4. Connector Pinouts.	8
Table 5. Video Input Descriptions.	10
Table 6. Digital Luminance Control	12
Table 7. Analog Luminance Control.....	12
Table 8. Optical Characteristics.	13
Table 9. Environmental Characteristics.....	14
Table 10. Mechanical Characteristics.	15

EL640.200-SK Half-VGA Display

The EL640.200-SK thin film electroluminescent (EL) display is a high-performance alternative to industry-standard LCDs and is the ideal solution in demanding applications where superior visual performance and environmental ruggedness are critical. The EL640.200-SK utilizes Planar's proprietary Integral Contrast Enhancement (ICE™) technology to achieve unparalleled image quality without the use of expensive filters. This display excels in a wide range of ambient lighting environments while effectively eliminating the blooming common to other high-bright displays.

The display consists of an EL glass panel and control electronics assembled into a space-saving, rugged package for easy mounting. The EL640.200-SK is easily interfaced using standard 4-bit or 8-bit LCD control signals. Each pixel is individually addressable to clearly display high information content graphics and text.

Features and Benefits

- Excellent visual performance:
 - High brightness and contrast
 - Wide viewing angle > 160°
- Rapid display response < 1 ms
- Frame buffer provides compatibility with low-cost LCD video controllers
- Space efficient mechanical package
- Low power
- Low EMI emissions
- Extremely rugged and durable
- Reliable, long operating life
- 4-bit buffered and 8-bit non-buffered dual-panel LCD-type interfaces

Installation and Handling

Do not drop, bend, or flex the display. Do not allow objects to strike the surface of the display.

CAUTION: The display uses CMOS and power MOSFET devices. These components are electrostatic sensitive. Unpack, assemble, and examine this assembly in a static-controlled area only. When shipping, use packing materials designed for protection of electrostatic-sensitive components.

Mounting EL Displays

Properly mounted, EL displays can withstand high shock loads as well as severe vibration found in demanding applications. However the glass panel used in an EL display will break if subjected to bending stresses, high impact, or excessive loads.

Avoid bending the display. Stresses are often introduced when a display is mounted into a product. Ideally, the mounting tabs of the display should be the only point of contact with the system. Use a spacer or boss for support; failure to do so will bend the display and cause the glass to break. The instrument enclosure or frame should not flex or distort in such a way that during use the bending loads might be transferred to the display. The EL640.200-SK mounting tabs were designed for a 3 mm screw. Mounting surfaces should be flat to within ± 0.6 mm (± 0.025 "). Use all the mounting holes provided. Failure to do so will impair the shock and vibration resistance of the final installation.

CAUTION: To prevent injury in the event of glass breakage, a protective overlay should be used on the viewer side of the display.

WARNING: These products generate voltages capable of causing personal injury (high voltage up to 235 V_{ac}). Do not touch the display electronics during operation.

Cable Length

A maximum cable length of 600 mm (24 in.) is recommended. Longer cables may cause data transfer problems between the data transmitted and the display input connector. Excessive cable lengths can pick up unwanted EMI. There are third party products which allow this maximum cable length to be exceeded. Contact Planar Application Engineering for more information.

Cleaning

As with any glass or coated surface, care should be taken to minimize scratching. Clean the display glass with mild, water-based detergents only. Apply the cleaner sparingly to a soft cloth, then wipe the display. Disposable cleaning cloths are recommended to minimize the risk of inadvertently scratching the display with particles embedded in a re-used cloth. Particular care should be taken when cleaning displays with anti-glare and anti-reflective films.

Avoiding Burn-In

As with other light emitting displays, use a screen saver or image inversion to avoid causing burn-in on the display. Displaying fixed patterns on the screen can cause burn-in, where luminance variations can be noticed over time.

Specifications

Performance characteristics are guaranteed when measured at 25°C with rated input voltage unless otherwise specified. The minimum and maximum specifications in this manual should be met, without exception, to ensure the long-term reliability of the display. Planar does not recommend operation of the display outside these specifications.

Control Basics

The EL panel is a matrix structure with column and row electrodes arranged in an X-Y formation. Light is emitted when an AC voltage of sufficient amplitude is applied at a row-column intersection. The display operation is based on the symmetric, line-at-a-time data addressing scheme.

Power

The supply voltages are shown in Table 1. All internal high voltages are generated from the display supply voltage (V_H).

Table 1. DC Input Voltage Requirements.

Parameter ¹	Symbol	Min	Typ	Max	Absolute Max ²
Logic voltage	V_L	4.75 V		5.25 V	
Logic voltage absolute max.	V_{Lmax}	-0.5 V		6 V	
Logic supply current at +5 V	I_L			150 mA	
Display supply voltage	V_H	8 V		18 V	20 V
VH Supply current at +8 V	I_H			2.1 A	
Power consumption 5 V/12 V			7.5 W	17.0 W	

1 Operating conditions: ambient temperature 25°C, 240 Hz frame rate.

2 Absolute max. ratings are those values beyond which damage to the device may occur.

There is no overcurrent protection on either the V_H or V_L inputs to protect against catastrophic faults. Planar recommends the use of a series fuse on the 12-volt supply (V_H). A general guideline is to rate the fuse at 1.8 to 2 times the display maximum current rating.

Table 2. Video Input Requirements.

Description	Symbol	Min	Max	Units
Absolute Maximum Input voltage	V_{IMAX}	-0.5	$V_L + 0.5$	V
Low-level Input voltage	V_{IL}	0	20% V_L	V
High-level Input voltage	V_{IH}	70% V_L	V_L	V_{CC}
Low-level input current	I_{IL}	–	-0.4	mA
High-level input current	I_{IH}	–	10	μ A

All video inputs are CMOS compatible with 470 Ω series resistors. Selftest, HS, VIDMODE, LUM0, and LUM1 have 10 k Ω pull-up resistors.

Table 3. Power Consumption

Brightness Level	25%	50%	75%	100%
Maximum Mean (W)	3.35	5.7	8.1	10.4
Absolute Maximum, estimated (W) 70% of pixels on per row	4.5	9	13	17
Typical (W) 20% of pixels on per row	3.0	4.7	6.2	7.5

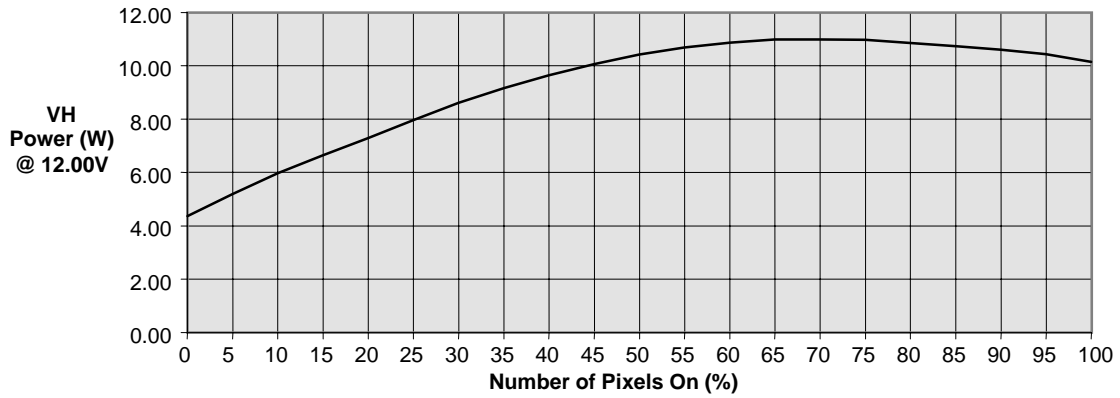

Figure 1. EL640.200-SK Power Curve (typical, @ 100% luminance level)

Connector

Video signals and DC power are connected to the display through a 24-contact dual-row 2 mm square pin locking connector, Samtec EHT-112-01-S-D. The mating connector is available through Samtec as an IDC cable assembly (Series TCSD-12-S-XX-01-X-X). The proper connector, user-specified cable length, and connector configuration are supplied as a single unit. Consult your Samtec representative (1-800-SAMTEC9) for cable and connector options.

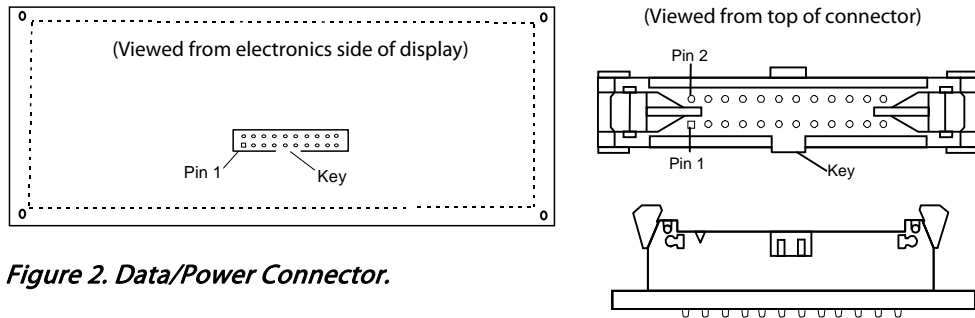

Figure 2. Data/Power Connector.

Table 4. Connector Pinouts.

Pin	Signal	Description	Pin	Signal	Description
1	VID1 (U1)	Video Data	2	VID0 (U0)	Video Data
3	VID3 (U3)	Video Data	4	VID2 (U2)	Video Data
5	VID (L3)	Video, Lower Panel	6	VID (L2)	Video, Lower Panel
7	VID (L1)	Video, Lower Panel	8	VID (L0)	Video, Lower Panel
9	VCLK	Video Clock	10	GND	Ground
11	HS	Horizontal Sync	12	GND	Ground
13	VS	Vertical Sync	14	GND	Ground
15	Selftest	Selftest Input	16	GND	Ground
17	VL (+5V)	+5 V Power	18	VIDMODE	Selects video mode
19	VH (+12V)	+12 V Power	20	VH (+12V)	+12 V Power
21	LUM 0	Digital dimming	22	LUM1	Digital dimming
23	GND	Ground	24	LUMA	Analog dimming input

Interface Information

This Planar EL display has two types of video interfaces for buffered and non-buffered modes. Changing from buffered to non-buffered mode or vice versa can be done during operation of the display. Pull VIDMODE, pin 18, low for non-buffered mode, and pull it high or leave it disconnected for buffered mode.

This display includes an internal frame buffer that is active when the display is in buffered mode. In buffered mode, the display scan rate and the display brightness are independent of user-supplied input data timing. The display frequency is controlled through the digital dimming feature as described below.

Buffered Video Mode

The input timing in the buffered mode is compatible with standard 4-line LCD single-scan controllers made by a variety of manufacturers. Designers should select the chip set that best suits their particular architecture and price point. The display scan rate, set by LUM0 and LUM1, is independent of the input video frame rate. This allows the user to achieve maximum brightness even at low input video frame rates for minimizing power consumption and EMI.

In buffered mode, four preset display scan rates can be selected. In addition to these four luminance steps, an analog luminance-control function is available (see Dimming on page 11). Due to the timing independence of the input data and the display scan, an image will be shown on the display even without any video input data. When using averaging grayscale algorithms, visual artifacts may be more easily perceived in buffered mode than in non-buffered mode.

Note: The display includes an internal frame buffer. In buffered mode the display scan is independent of the input video. In order to blank the display image in the event of system malfunction, pull VIDMODE low to exit the buffered mode.

Non-buffered Video Mode

The input timing in non-buffered mode is an eight-line dual-screen interface. The display panel is divided into an upper screen (rows 1 through 100) and a lower screen (rows 101 through 200). Four pixels for each screen—eight pixels total—are input on every video clock cycle. The video interface in non-buffered mode is similar to what is used to drive monochrome dual-panel LCD displays. The non-buffered mode provides the user with full control of the display scan rate. It also enables the use of gradual dimming with frame rate and the use of averaging grayscale algorithms. For additional dimming independent of frame-rate, an analog luminance-control function is available (see Dimming on page 11).

In non-buffered mode, video data must be supplied continuously. If the supported frame rate range of the available display controller limits the achievable brightness, the buffered mode can be used for high-brightness operation.

Video Input Signals

The end of the top line of a frame is marked by **VS**, vertical sync signal as shown in Figure . The end of each row of data is marked by **HS**. In non-buffered mode, the **VS** signal may be independently set to a CMOS low level at any time for longer than one frame period. During the time of **VS** inactivity the display is blank. Halting **VS** results in a standby condition to minimize power usage in buffered mode.

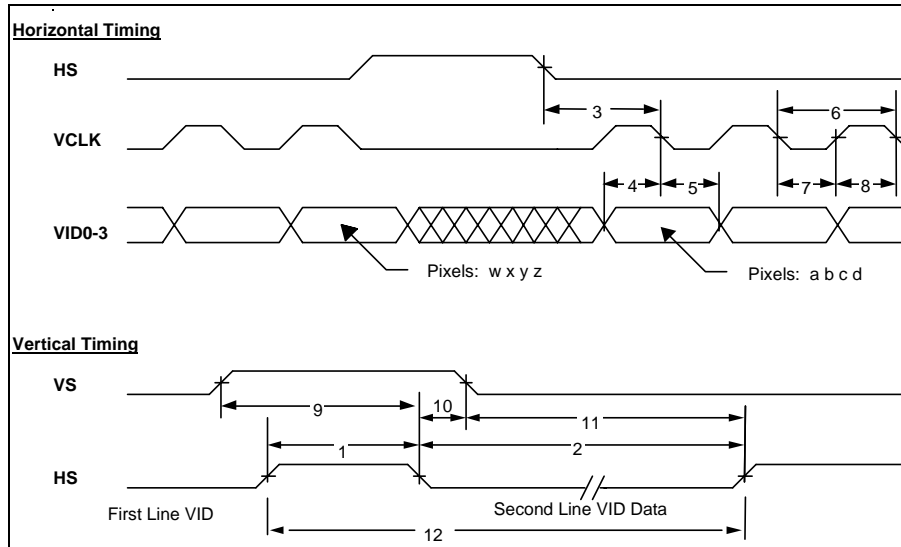

Figure 3. Video Input Timing Diagram.

Table 5. Video Input Descriptions.

Num	Description	Symbol	Min.	Max.	Units
1	HS high time	tHSh	125		nsec
2	HS low time	tHSl	160		tVCLK
3	HS to VCLK	tHSsu	63		nsec
4	VID setup to VCLK	tVIDsu	100		nsec
5	VID hold from VCLK	tVIDhd	100		nsec
6	Video clock period	tVCLK	334 (200*)		nsec
	VCLK rise, fall time	tVCLKrf		50	nsec
7	VCLK low width	tVCLKl	125		nsec
8	VCLK high width	tVCLKh	125		nsec
9	VS high setup to HS low	tVShsu	100		nsec
10	VS hold after HS	tVShd	100		nsec
11	VS low setup to HS high	tVSlisu	140		nsec
12	HS period	tHS	53.6 (41.3*)		µsec
	VS period	tVS	200 (101*)		tHS
	Max frame rate*		239*		Hz

* Non-buffered mode

Video Data in Non-Buffered Mode

In non-buffered mode, input signals **VID0** through **VID3** and **VIDL0** through **VIDL3** contain the video data for the screen. Video data for row n and row $n+100$ is latched on the falling edge of **HS**, as shown in Figure 3.

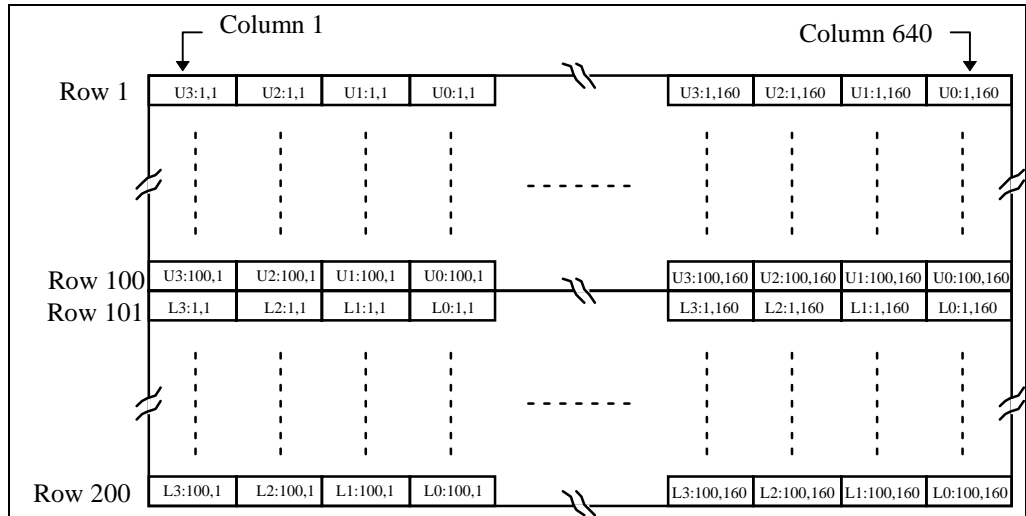

Figure 4. Pixel Location versus Sequence of Data in Non-buffered Mode.

Video Data in Non-Buffered Mode

In buffered mode, input signals **VID0** through **VID3** contain the video data for the screen. Pixel information is supplied from left to right and from top to bottom four pixels at a time. Video data for one row is latched on the falling edge of **HS**, as shown in Figure 3.

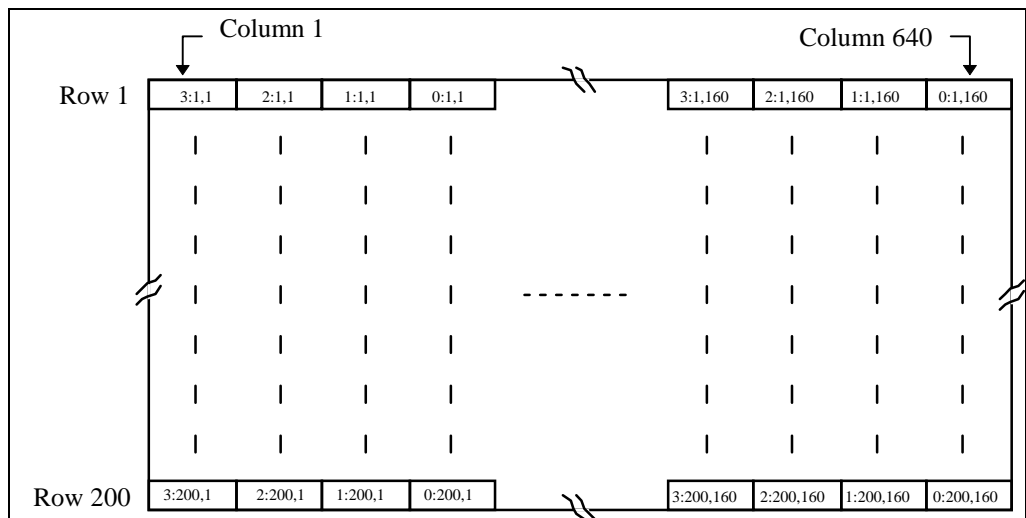

Figure 5. Pixel Location versus Sequence of Data in Buffered Mode.

Dimming

There are two standard methods for dimming the EL640.200-SK display. To perform analog dimming in either buffered or non-buffered mode, connect a 100 K Ω variable resistor between LUMA and GND. Alternatively, an external voltage or current mode D/A converter may be used to facilitate dimming by sinking a maximum of 250 μ A nominal (for maximum dimming) from LUMA to GND on the input connector. Open circuit voltage is 5 V nominal.

To perform digital dimming in buffered mode, the internal scan frequency is controlled via the LUM1 and LUM0 inputs. When these inputs are left open, the display is scanned at 240 Hz—the maximum scan rate. With the combination of the two inputs, LUM1 and LUM0, the following scan frequencies are obtained:

Table 6. Digital Luminance Control.

Approx. Relative Luminance	Max	75%	50%	25%
LUM1	1	1	0	0
LUM0	1	0	1	0
Frame rate (Hz) *	240	180	120	60

Analog Luminance Control

Luminance control circuitry is provided to allow the user to adjust the luminance from 5 to 100 percent of the maximum. Connecting a 100 K Ω variable resistor between LUMA and GND will give a brightness range from approximately 5 to 100 percent of the full luminance value. Alternatively, an external voltage or current mode D/A converter may be used to facilitate dimming by sinking a maximum of 250 μ A (for maximum dimming) from LUMA to GND on the input connector.

Table 7. Analog Luminance Control.

Approx. Relative Luminance	Dimming
Maximum (No resistor connected)	100 % (Default)
Maximum (100 K Ω resistor connected)	100 %
Minimum (0 Ω resistor connected)	5% maximum, 0% minimum
Open Circuit voltage	5V nominal
Sink Current	250 μ A nominal, $V_{in} = 0V$

Brightness values are measured as a percentage of full On Luminance with the external resistor disconnected.

Self-Test Mode

The display incorporates a self-test mode composed of a 1 x 2 checkerboard and full-on pattern displayed at 240 Hz. Upon power up, the 1 x 2 pattern is displayed for several seconds, then the full-on pattern is displayed continuously. The self-test mode is entered by leaving the SELFTEST pin pulled high. For normal operation the SELFTEST pin must be pulled to a logic low. If the SELFTEST pin is pulled high during normal operation, the display will enter the self-test mode.

Optical

Table 8. Optical Characteristics.

Luminance		
L _{on} (areal), min	63.5 cd/m ²	screen center, 240 Hz frame rate
L _{on} (areal), typ	80.6 cd/m ²	screen center, 240 Hz frame rate
L _{off} (areal), max	.20 cd/m ²	5 points @ 240 Hz
Non-uniformity		
All pixels fully lit	26%	Maximum difference two of five points, using the formula: LNU%=[1- (min_lum/max_lum)] x 100%
Luminance Variation (Temperature)		
Maximum	±25%	Across operating temperature range
Luminance Variation (Time)		
Maximum	<20%	10,000 hours at 25°C ambient
Viewing Angle		
Minimum	160°	
Contrast Ratio		
240 Hz frame rate	40.5	@ 500 Lux
	5.5	@ 5,000 Lux
	1.5	@50,000 Lux

Environmental

Table 9. Environmental Characteristics.

Temperature	
Operating	-40°C to +85°C
Non-operating	-50°C to +105°C*
Operating Survival	-45°C to +105°C**
Humidity	
Non-condensing, operating	93% RH @ 40°C, per IEC 68-2-3
Condensing, non-operating	95% RH @ 25-55°C, per IEC 68-2-30
Altitude	
Operating/non-operating	0 to 18 km (58k ft) per IEC 68-2-13
Vibration	
operating/ non-operating	Random, 0.02 g ² /Hz, 5-500 Hz, 30 minutes each axis per IEC 68-2-34
operating/ non-operating	Sinusoidal, 1.50 mm amplitude, 10 g max., 10-55-10 Hz, 1 min./cycle, 60 minutes each axis
Shock	
operating/ non-operating	100 g, 6 ms, half sine wave, per IEC 68-2-27

* After 12 hours at -50°C, acclimatize the display at -40°C min. before power on.

** Operating survival: at extremes for 1 hour maximum.

Reliability

The display MTBF is to be greater than 50,000 hours at 120 Hz with a 90% confidence level at 25°C.

Safety and EMI Performance

The display will not inhibit the end product from obtaining certifications under UL1950, CSA22.2 No. 950, and EN60950. The display will not inhibit the end product from complying with FCC Part 15, Subpart J, Class B or EN55022 Class B when housed in a suitable enclosure.

Mechanical Characteristics

Table 10. Mechanical Characteristics.

Display External Dimensions		
millimeters (inches)	width	260.0 (10.24)
	height	104.1 (4.09)
	depth	19.0 (0.75)
<hr/>		
Weight (typical)	306g (10.79 oz)	
<hr/>		
Fill Factor	59.3%	
<hr/>		
Display Active Area millimeters (inches)	width	211.17 (8.31)
	height	79.17 (3.12)
	diagonal	225.52 (8.87)
<hr/>		
Pixel Size millimeters (inches)	width	.25 (0.009)
	height	.31 (0.012)

Component Envelope

The component envelope shown in Figure illustrates the distance components extend behind the display. Tall components do not necessarily fill this area. Planar reserves the right to relocate components *within* the constraints of the component envelope without prior customer notification. For this reason, Planar advises users to design enclosure components to be outside the component envelope. Device designers will need to consider their specific system requirements to determine the spacing necessary to maintain the specified ambient temperature. Air flow and surrounding component materials will affect the depth of the air gap.

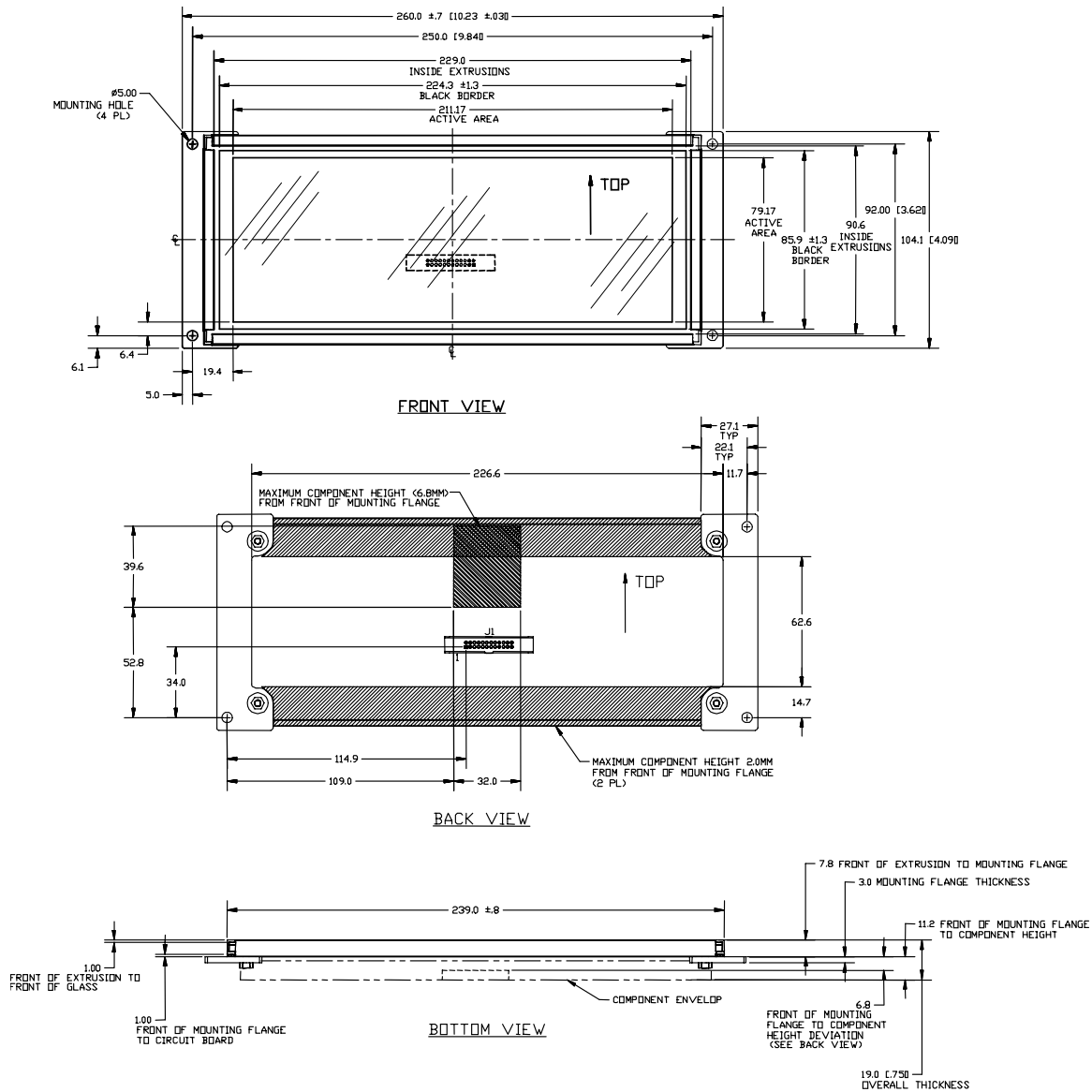

Dimensions in are millimeters; inches in brackets.

Tolerances unless specified

.x ±0.50 [0.02]

.xx ±0.25 [0.01]

Figure 6. Display Dimensions.

Note: Please refer to www.planar.com/support to view the mechanical drawing.

Description of Warranty

Seller warrants that the Goods will conform to published specifications and be free from defects in material for 12 months from delivery. To the extent that Goods incorporate third-party-owned software, Seller shall pass on Seller's licensor's warranty to Buyer subject to the terms and conditions of Seller's license.

Warranty repairs shall be warranted for the remainder of the original warranty period. Buyer shall report defect claims in writing to Seller immediately upon discovery, and in any event, within the warranty period. Buyer must return Goods to Seller within 30 days of Seller's receipt of a warranty claim notice and only after receiving Seller's Return Goods Authorization. Seller shall, at its sole option, repair or replace the Goods.

If Goods were repaired, altered or modified by persons other than Seller, this warranty is void. Conditions resulting from normal wear and tear and Buyer's failure to properly store, install, operate, handle or maintain the Goods are not within this warranty. Repair or replacement of Goods is Seller's sole obligation and Buyer's exclusive remedy for all claims of defects. If that remedy is adjudicated insufficient, Seller shall refund Buyer's paid price for the Goods and have no other liability to Buyer.

All warranty repairs must be performed at Seller's authorized service center using parts approved by Seller. Buyer shall pay costs of sending Goods to Seller on a warranty claim and Seller shall pay costs of returning Goods to Buyer. The turnaround time on repairs will usually be 30 working days or less. Seller accepts no added liability for additional days for repair or replacement.

If Seller offers technical support relating to the Goods, such support shall neither modify the warranty nor create an obligation of Seller. Buyer is not relying on Seller's skill or judgment to select Goods for Buyer's purposes. Seller's software, if included with Goods, is sold as is, and this warranty is inapplicable to such software.

SELLER DISCLAIMS ALL OTHER WARRANTIES, EXPRESS OR IMPLIED, INCLUDING BUT NOT LIMITED TO, IMPLIED WARRANTIES OF MERCHANTABILITY AND FITNESS FOR A PARTICULAR PURPOSE.

Ordering Information

Product	Part Number	Features
EL640.200-SK ALE	996-0290-05	Standard version
EL640.200-SK CC ALE	996-0290-06	EL640.200-SK ALE with conformal coating

Design and specifications are subject to change without notice.

Planar Systems continues to provide optional, and in many cases custom, features to address the specific customer requirements. Consult Planar Sales for pricing, lead time and minimum quantity requirements.

Support and Service

Planar is a U.S. company based in Beaverton, Oregon and Espoo, Finland, with a world-wide sales distribution network. Full application engineering support and service are available to make the integration of Planar displays as simple and quick as possible for our customers.

RMA Procedure: For a *Returned Material Authorization* number, please contact Planar Systems, Inc. with the model number(s) and serial number(s). When returning goods for repair, please include a brief description of the problem, and mark the outside of the shipping container with the RMA number.

Planar Systems, Inc.

Customer Service

24x7 Online Technical Support: <http://www.planar.com/support>

Americas Support

1195 NW Compton Drive

Beaverton, OR 97006-1992

Tel: 1-866-PLANAR1 (866) 752-6271

Hours: M-F, 5am - 5pm Pacific Time

Europe and Asia-Pacific Support

Olarinluoma 9 P.O. Box 46

FIN-02201 Espoo, Finland

Tel: +358-9-420-01

Hours: M-F, 7:00am - 4pm CET

© 2005 **Planar Systems, Inc. 06/05** Planar is a registered trademark of Planar Systems, Inc.

ICE, ICEBrite, and ICEPlus are trademarks of Planar Systems, Inc.

Other brands and names are the property of their respective owners.

Technical information in this document is subject to change without notice.

020-0348-00B