

**har-pak®**, 2.50 mm pitch

Page

<b>har-pak®</b> connector system – general information .....	<b>05.02</b>
Contact arrangements .....	<b>05.03</b>
Technical characteristics .....	<b>05.04</b>
<b>Male connectors</b>	
1 SU (SU = <b>S</b> ystem <b>U</b> nit = 25 mm) .....	<b>05.06</b>
2 SU .....	<b>05.07</b>
2.3 SU .....	<b>05.08</b>
4 SU .....	<b>05.09</b>
5.4 SU .....	<b>05.10</b>
9 SU .....	<b>05.11</b>
10 SU .....	<b>05.12</b>
<b>Female connectors</b>	
1 SU (SU = <b>S</b> ystem <b>U</b> nit = 25 mm) .....	<b>05.13</b>
2 SU .....	<b>05.14</b>
2.3 SU .....	<b>05.15</b>
4 SU .....	<b>05.16</b>
5.4 SU .....	<b>05.17</b>
9 SU .....	<b>05.18</b>
10 SU .....	<b>05.19</b>
Guiding system .....	<b>05.20</b>

har-pak®

Future packaging systems for electronic equipment must be able to accommodate highly integrated components and be compatible with modern PCB assembly procedures.

har-pak® connectors<sup>1)</sup> are an integral part of the electrical and mechanical construction of such systems.

This new development is designed in a three dimensional modular format. Due to CAE/CIM, a flexible and cost effective system is offered to the user, from design stage through to production. All existing and projected future packaging requirements are met by har-pak®.

Typical requirements of such a connector system are as follows:

- High contact density
- Modular construction designed for state of the art backplane wiring techniques
- Solderless termination techniques

With har-pak®, an optimum utilisation of space is achieved with no loss of contact pitch when components are joined together. The minimum daughtercard pitch is only 15 mm.

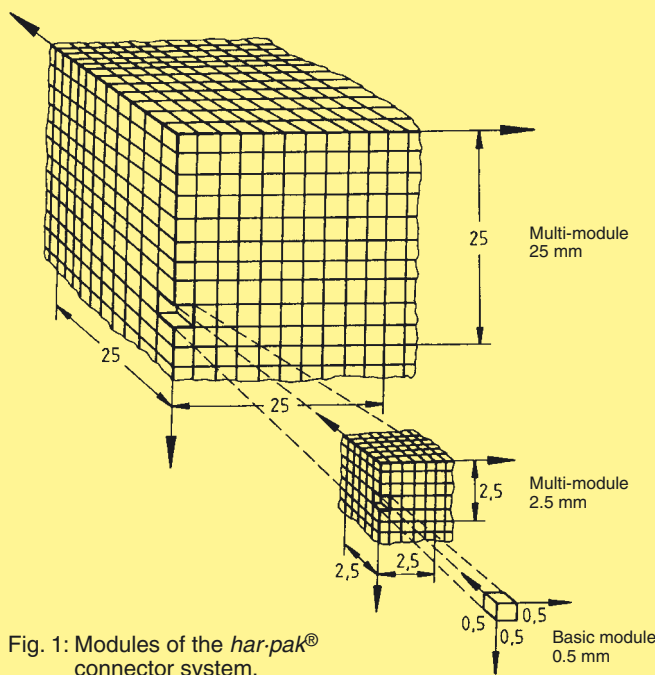

Fig. 1: Modules of the har-pak® connector system.

The concept of the har-pak® packaging system realises a homogeneous continuing pitch. Units of height, width and depth are formed by single modules of 0.5 mm or multi-modules of 2.5 mm (see Fig. 1).

The construction of har-pak® considers the possibility of combinations with other standardised packaging systems and meets all technical requirements of data communication, medical and process control markets.

har-pak® connectors are available in sizes 1 SU, 2 SU, 2.3 SU, 4 SU, 5.4 SU, 9 SU and 10 SU according to IEC 61 076-4-100 (SU = System Unit = 25 mm).

The 5 row arrangement with the 10 SU version carries up to 475 contacts in one connector module. Customised designs of this indirect, inverse connector system are available on request.

Male and female connectors accommodate coaxial, high current, first mate contacts and are designed in solderless press-in technique. An optimum screening concept for protection against Electromagnetic Interference (EMI) is achieved by pseudo coaxial contact arrangements.

Male and female connectors offer the following benefits:

Male connectors

- Precision contacts, including the interface system
- Reliable press-in technology for multilayer PCB's (up to 6.00 mm)<sup>2)</sup>
- Preleading/lagging contacts possible in all positions
- Contact plating for all performance levels
- Press-in contact header with compliant press-in zone

Female connectors

- Two contact points
- Contacts protected by moulding
- Contact plating for all performance levels
- Different contact loadings possible
- Integrated fixing elements
- Press-in contact with compliant press-in zone

<sup>1)</sup> specified acc. to IEC 61 076-4-100 (DIN 41 642, CECC 75 101-807 and others)

<sup>2)</sup> The maximal allowed board thickness depends on several parameters. For boards with more than 4.5 mm please contact us.

Identification	Cont. arr.	No. of contacts (SU)								Drawing	Dimensions in mm		
		1	2	2.3	4	5.4	9	10					
Female connector	3	12	27	30	57	78	132	147					
Male connector	7	12	27	30	57	78	132	147					
Female connector	2	18	43	50	93	126	214	239					
Male connector	6	18	43	50	93	126	214	239					
Female connector	8	28	68	80	148	200	340	380					
Male connector	4	28	68	80	148	200	340	380					
Female connector	1	35	85	100	185	250	425	475					
Male connector	1	35	85	100	185	250	425	475					
Screening of signals Examples of pseudo coaxial contact arrangements based on standard contact loadings	6												
	4												
	1												

Signal contact  
 Ground contact

har-pak®

Design according : IEC 61 076 - 4 - 100

Number of contacts : max. 475 at 10 SU

Contact spacing : 2.5 mm  
Clearance and creepage distances:

	contact arrangements (see page 05.03)			
	7/3	6/2	4/8	1
in one row	2.9 mm	0.8 mm	0.8 mm	0.8 mm
between rows	1.4 mm	0.8 mm	0.8 mm	0.6 mm

Working current : See current carrying capacity chart on page 09.05

Test voltage  $U_{r.m.s.}$  : 1 kV for pitch 2.5 x 2.5 mm  
1.55 kV for pitch 5.0 x 5.0 mm

Contact resistance :  $\leq 20 \text{ m}\Omega$

Insulation resistance :  $\geq 10^{12} \Omega$

Temperature range :  $- 55 \text{ }^\circ\text{C} \dots + 125 \text{ }^\circ\text{C}$

Durability as per IEC 61076-4-100 : Performance level 2 = 250 mating cycles in total.  
Performance level 1 = 500 mating cycles in total.

Normal force :  $\geq 0.75 \text{ N}$  for performance level 2  
 $\geq 1.0 \text{ N}$  for performance level 1

Insertion force :  $\leq 1.0 \text{ N}$  per contact

Withdrawal force :  $\leq 1.0 \text{ N}$  per contact

Recommended configuration of plated through holes:

<i>Tin plated PCB (HAL) acc. EN 60 352-5</i>	Hole-Ø	1.15 $\pm$ 0.025 mm
	Cu	min. 25 $\mu\text{m}$
	Sn	max. 15 $\mu\text{m}$
	Plated hole-Ø	0.94-1.09 mm
<i>Chemical tin plated PCB</i>	Hole-Ø	1.15 $\pm$ 0.025 mm
	Cu	min. 25 $\mu\text{m}$
	Sn	min. 0.8 $\mu\text{m}$
	Plated hole-Ø	1.00-1.10 mm
<i>Au / Ni plated PCB</i>	Hole-Ø	1.15 $\pm$ 0.025 mm
	Cu	min. 25 $\mu\text{m}$
	Ni	3-7 $\mu\text{m}$
	Au	0.05-0.12 $\mu\text{m}$
	Plated hole-Ø	1.00-1.10 mm
<i>Silver plated PCB</i>	Hole-Ø	1.15 $\pm$ 0.025 mm
	Cu	min. 25 $\mu\text{m}$
	Ag	0.1-0.3 $\mu\text{m}$
	Plated hole-Ø	1.00-1.10 mm
<i>OSP copper plated PCB</i>	Hole-Ø	1.15 $\pm$ 0.025 mm
	Cu	min. 25 $\mu\text{m}$
	Plated hole-Ø	1.00-1.10 mm

PCB board thickness:  $\geq 1.6 \text{ mm}$

Materials

Mouldings : Thermoplastic resin, glass-fibre filled, UL 94-V0

Contacts : Copper alloy

Contact surface\*

Contact zone : Selectively gold-plated

Press-in-zone : Ni

Termination for interfacing : Wrap zone : Ni  
Interface : Au

\* Other contact surfaces on request

**Current carrying capacity**

The current carrying capacity is limited by maximum temperature of materials for inserts and contacts including terminals. The current capacity curve is valid for continuous, non interrupted current loaded contacts of connectors when simultaneous power on all contacts is given, without exceeding the maximum temperature.

Control and test procedures according to DIN IEC 60 512

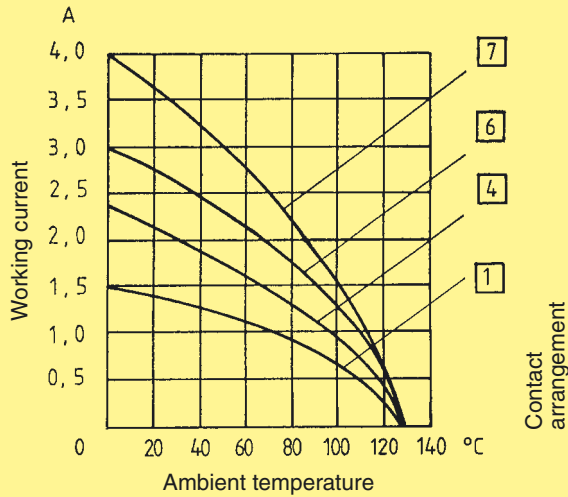

**Inductivity**

Contact arrangement	max. inductivity	max. counter inductivity between two contacts
7/3	26 nH	9 nH
6/2	26 nH	11 nH
4/1/8	28 nH	15 nH

All part numbers shown in this chapter contain the standard mating pin length of 8.45 mm. Any customized configuration on request.

**Capacitance**

Contact arrangement	between adjacent contacts			between surrounding contacts		
	K	M	L	K	M	L
7/3	0.6 pF	0.7 pF	0.8 pF	1.4 pF	1.6 pF	1.7 pF
6/2	0.7 pF	0.8 pF	0.9 pF	1.7 pF	1.9 pF	2.0 pF
4/1/8	1.2 pF	1.3 pF	1.4 pF	2.5 pF	2.8 pF	3.0 pF

K = Male connector with press-in termination

M = Male connector with press-in termination and 2 wraps

L = Male connector with press-in termination and 3 wraps

**Mating conditions as per DIN EN 61 076-4-100**

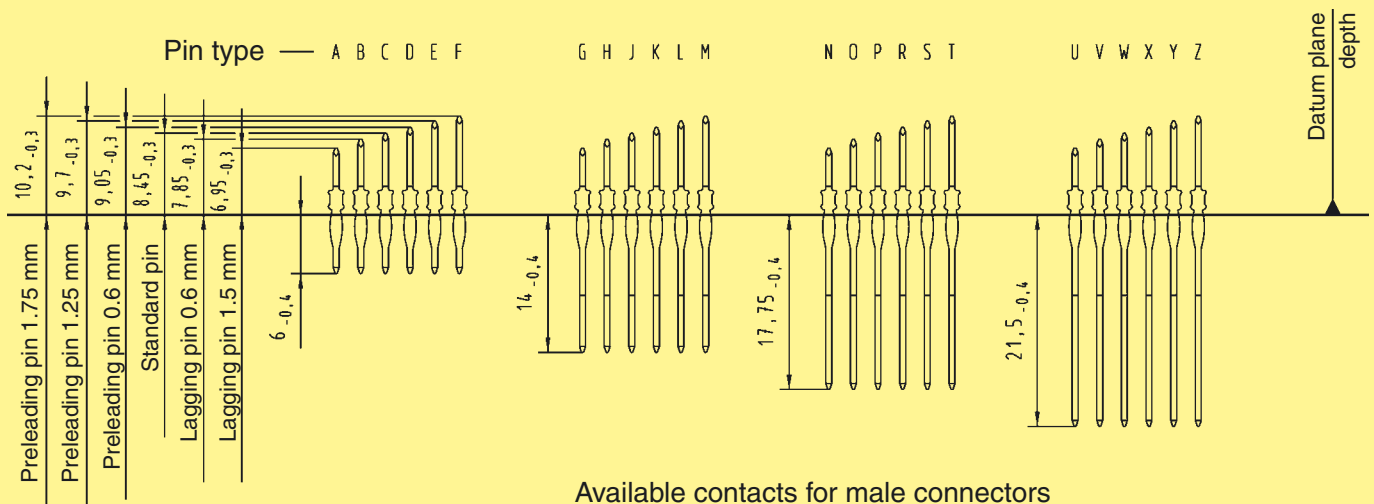
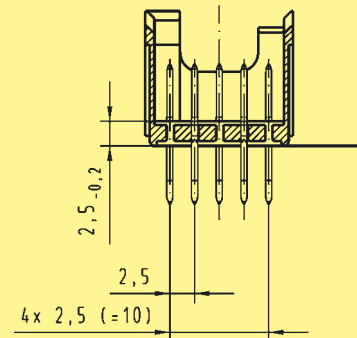
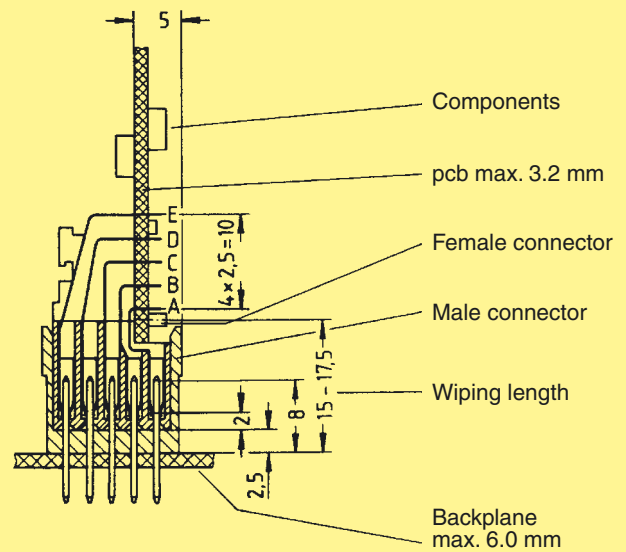

Available contacts for male connectors

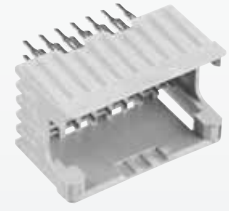

Male connectors, straight

Identification		Number of contacts	Contact arrangement*	Part number
1 SU male connector with press-in termination	6.0 mm	12	7	07 01 711 7015 <b>07 01 711 8015</b>
		18	6	07 01 611 7015 <b>07 01 611 8015</b>
		28	4	07 01 411 7015 <b>07 01 411 8015</b>
		35	1	07 01 111 7015 <b>07 01 111 8015</b>
	14.0 mm	12	7	07 01 712 7015 <b>07 01 712 8015</b>
		18	6	07 01 612 7015 <b>07 01 612 8015</b>
		28	4	07 01 412 7015 <b>07 01 412 8015</b>
		35	1	07 01 112 7015 <b>07 01 112 8015</b>

Connector dimensions [mm]

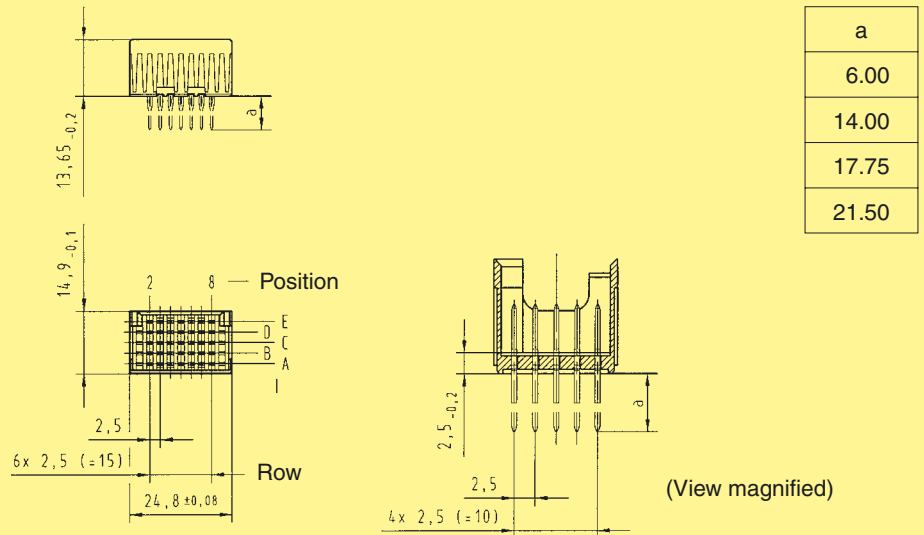

Board drillings

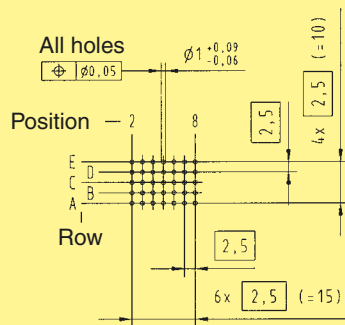

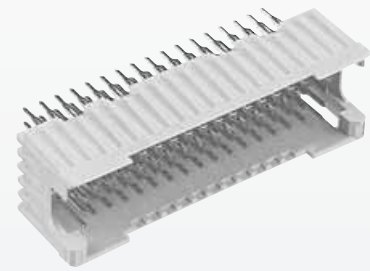

Male connectors, straight

Identification	Number of contacts	Contact arrangement*	Part number
2 SU male connector with press-in termination	6.0 mm	27	07 02 711 7015 <b>07 02 711 8015</b>
		43	07 02 611 7015 <b>07 02 611 8015</b>
		68	07 02 411 7015 <b>07 02 411 8015</b>
		85	07 02 111 7015 <b>07 02 111 8015</b>
	14.0 mm	27	07 02 712 7015 <b>07 02 712 8015</b>
		43	07 02 612 7015 <b>07 02 612 8015</b>
		68	07 02 412 7015 <b>07 02 412 8015</b>
		85	07 02 112 7015 <b>07 02 112 8015</b>

Connector dimensions [mm]

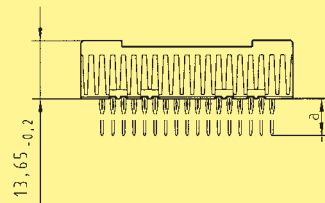

a
6.00
14.00
17.75
21.50

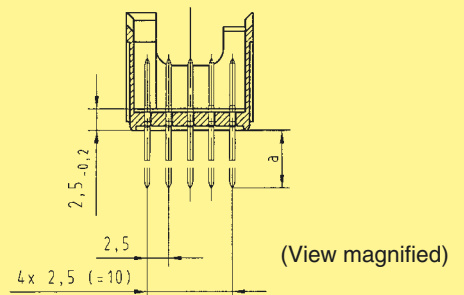
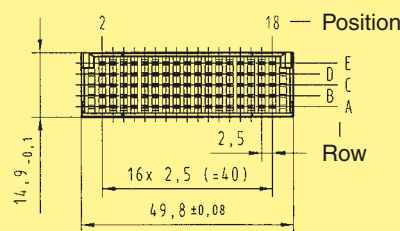

Board drillings

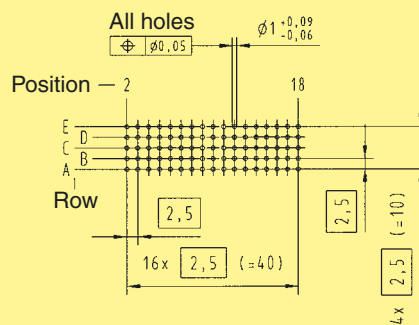

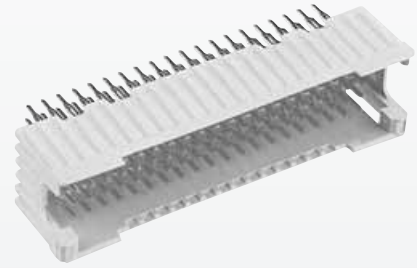

Male connectors, straight

Identification	Number of contacts	Contact arrangement*	Part number
2.3 SU male connector with press-in termination	6.0 mm	30	7 <b>07 02 711 8016</b>
		50	6 <b>07 02 611 8016</b>
		80	4 <b>07 02 411 8017</b>
		100	1 <b>07 02 111 8018</b>
		14.0 mm	30
	50		6 <b>07 02 612 8016</b>
	80		4 <b>07 02 412 8016</b>
	100		1 <b>07 02 112 8016</b>

Connector dimensions [mm]

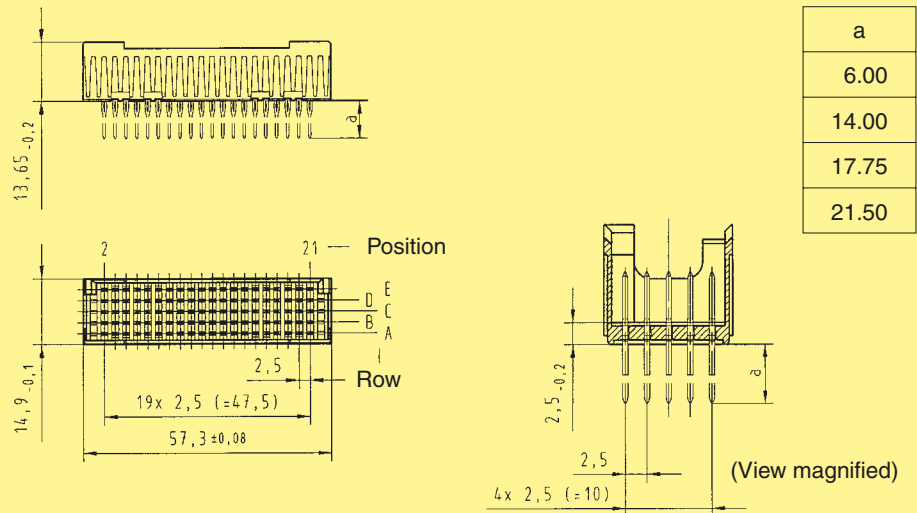

Board drillings

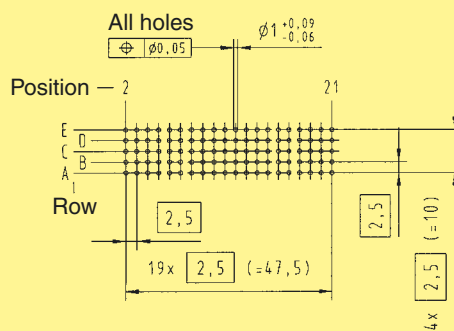



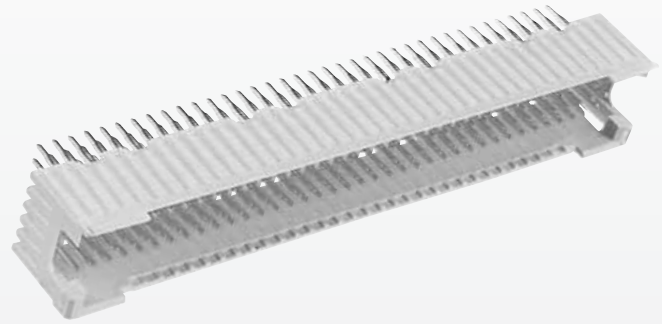

Male connectors, straight

Identification		Number of contacts	Contact arrangement*	Part number
4 SU male connector with press-in termination	6.0 mm	57	7	07 04 711 7015 <b>07 04 711 8015</b>
		93	6	07 04 611 7015 <b>07 04 611 8015</b>
		148	4	07 04 411 7015 <b>07 04 411 8015</b>
		185	1	07 04 111 7015 <b>07 04 111 8015</b>
	14.0 mm	57	7	07 04 712 7015 <b>07 04 712 8015</b>
		93	6	07 04 612 7015 <b>07 04 612 8015</b>
		148	4	07 04 412 7015 <b>07 04 412 8015</b>
		185	1	07 04 112 7015 <b>07 04 112 8015</b>

Connector dimensions [mm]

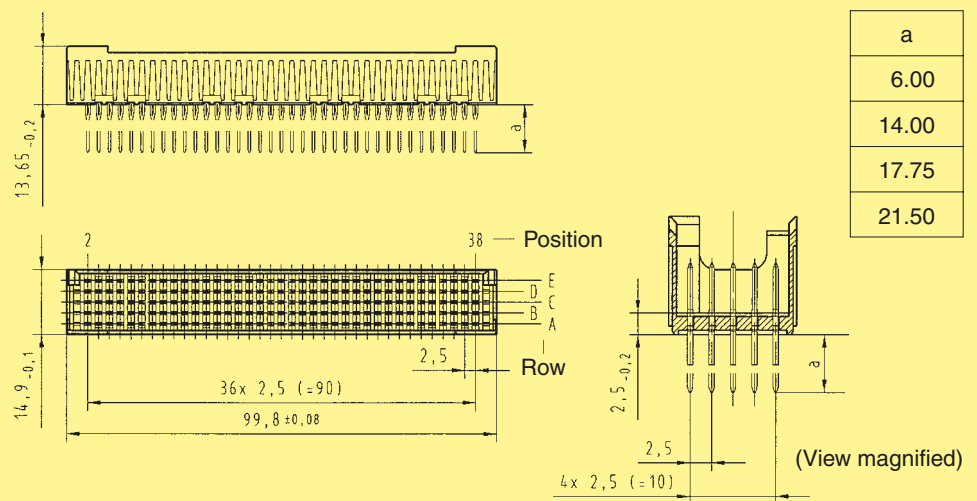

Board drillings

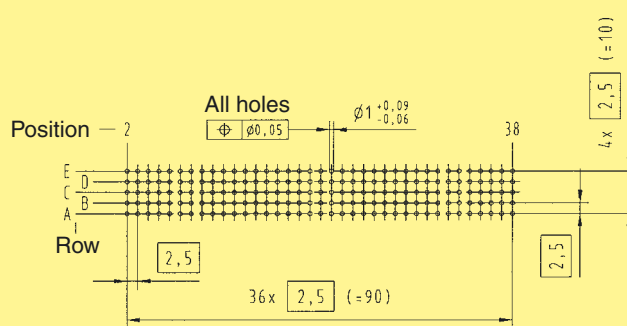

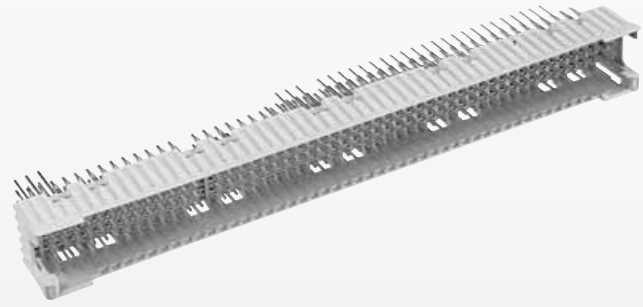

Male connectors, straight

Identification	Number of contacts	Contact arrangement*	Part number
5.4 SU male connector with press-in termination	6.0 mm	78	7 07 05 711 7015 <b>07 05 711 8015</b>
		126	6 07 05 611 7015 <b>07 05 611 8015</b>
		200	4 07 05 411 7015 <b>07 05 411 8015</b>
		250	1 07 05 111 7016 <b>07 05 111 8016</b>
	14.0 mm	78	7 07 05 712 7015 <b>07 05 712 8015</b>
		126	6 07 05 612 7015 <b>07 05 612 8015</b>
		200	4 07 05 412 7015 <b>07 05 412 8015</b>
		250	1 07 05 112 7015 <b>07 05 112 8015</b>

Connector dimensions [mm]

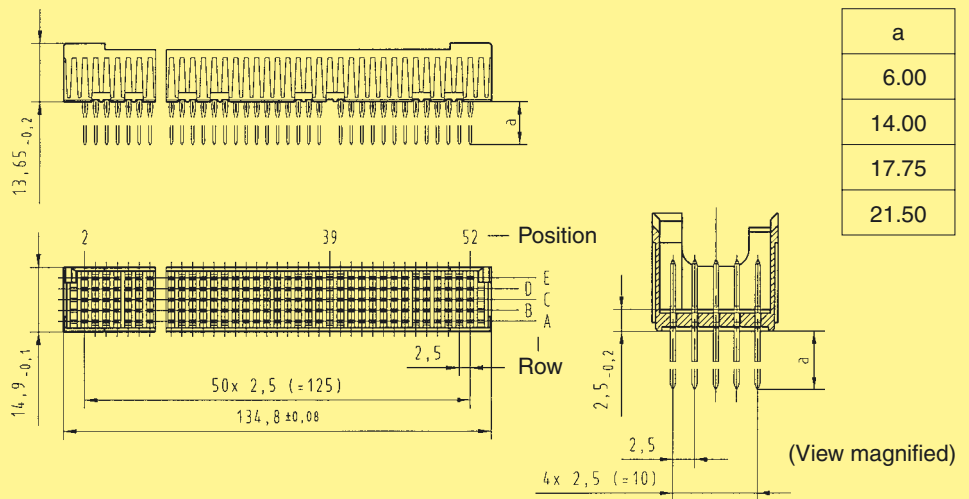

Board drillings

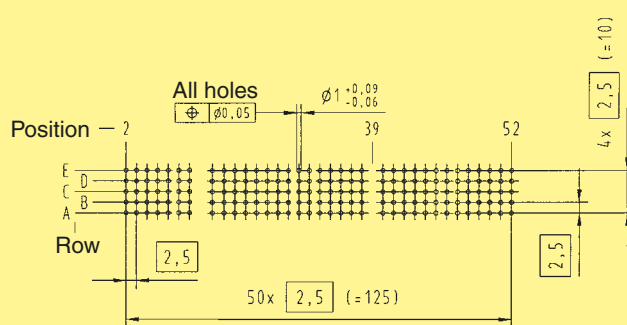

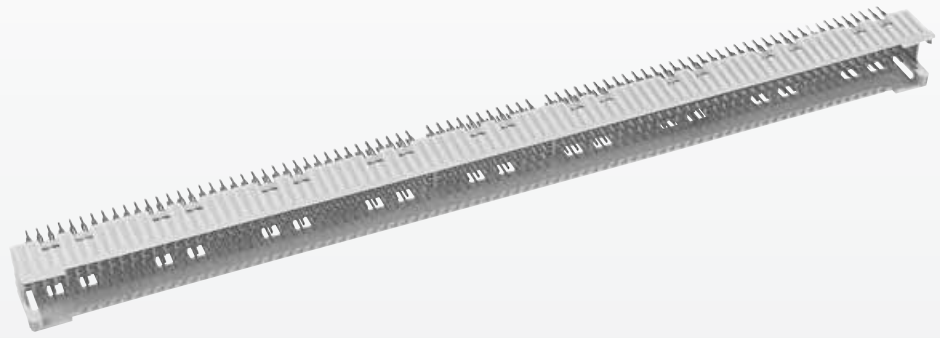

Male connectors, straight

Identification		Number of contacts	Contact arrangement*	Part number
9 SU male connector with press-in termination	6.0 mm	132	7	07 09 711 7015 <b>07 09 711 8015</b>
		214	6	07 09 611 7015 <b>07 09 611 8015</b>
		340	4	07 09 411 7015 <b>07 09 411 8015</b>
		425	1	07 09 111 7015 <b>07 09 111 8015</b>
	14.0 mm	132	7	07 09 712 7015 <b>07 09 712 8015</b>
		214	6	07 09 612 7015 <b>07 09 612 8015</b>
		340	4	07 09 412 7015 <b>07 09 412 8015</b>
		425	1	07 09 112 7015 <b>07 09 112 8015</b>

Connector dimensions [mm]

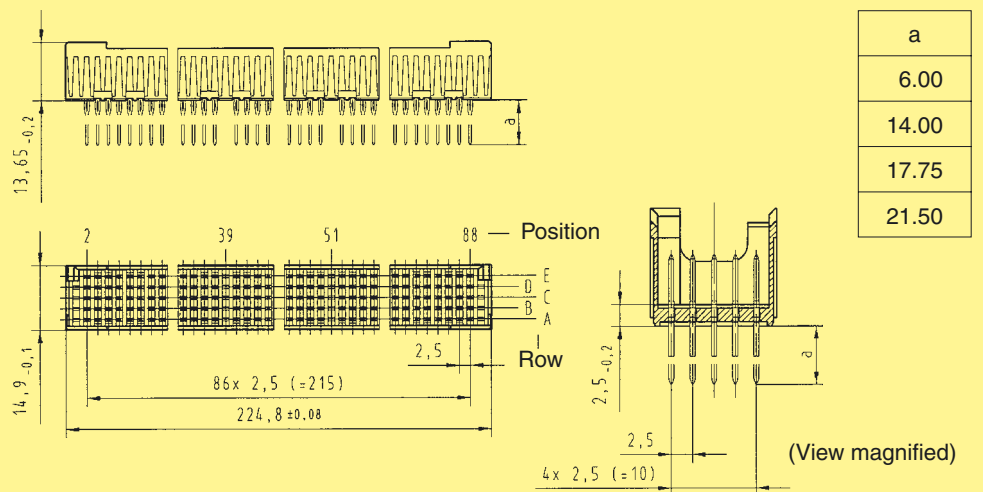

Board drillings

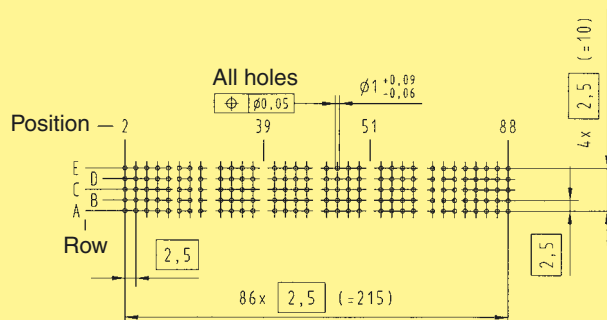

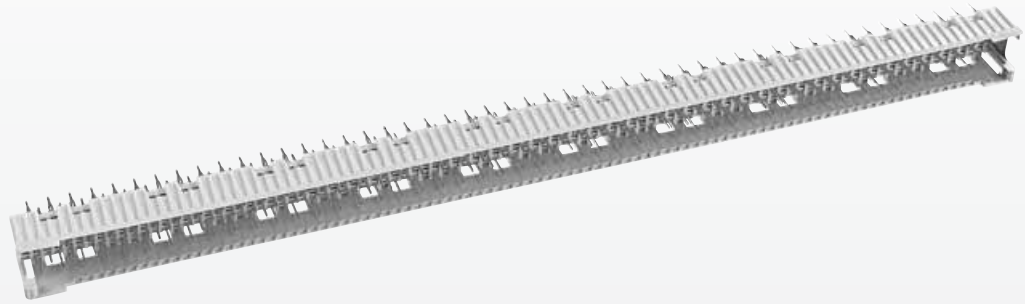

Male connectors, straight

Identification	Number of contacts	Contact arrangement*	Part number
10 SU male connector with press-in termination	6.0 mm	147	7 07 00 711 7015 <b>07 00 711 8015</b>
		239	6 07 00 611 7015 <b>07 00 611 8015</b>
		380	4 07 00 411 7015 <b>07 00 411 8015</b>
		475	1 07 00 111 7015 <b>07 00 111 8015</b>
	14.0 mm	147	7 07 00 712 7015 <b>07 00 712 8015</b>
		239	6 07 00 612 7015 <b>07 00 612 8015</b>
		380	4 07 00 412 7015 <b>07 00 412 8015</b>
		475	1 07 00 112 7015 <b>07 00 112 8015</b>

Connector dimensions [mm]

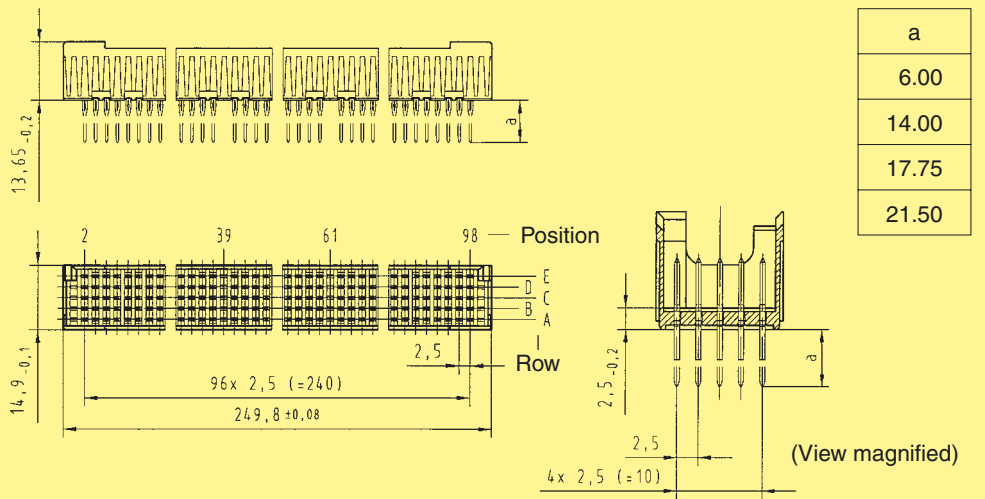

Board drillings

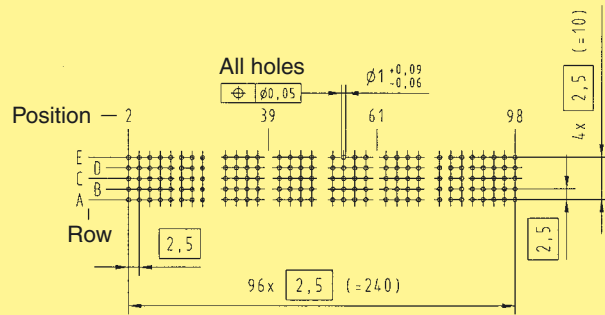

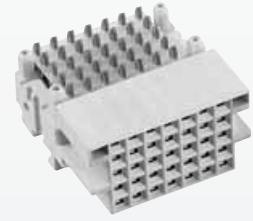

Female connectors, angled

Identification	Number of contacts	Contact arrangement*	Part number
1 SU female connector with press-in termination	12	3	07 21 319 7015 <b>07 21 319 8015</b>
	18	2	07 21 219 7015 <b>07 21 219 8015</b>
	28	8	07 21 819 7015 <b>07 21 819 8015</b>
	35	1	07 21 119 7015 <b>07 21 119 8015</b>

Connector dimensions [mm]

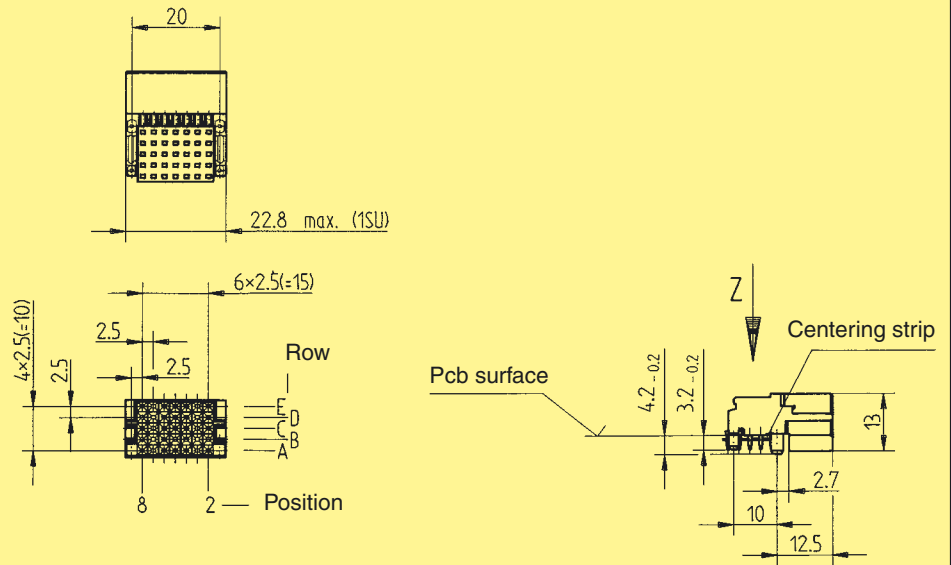

Board drillings (revolved by 90°)

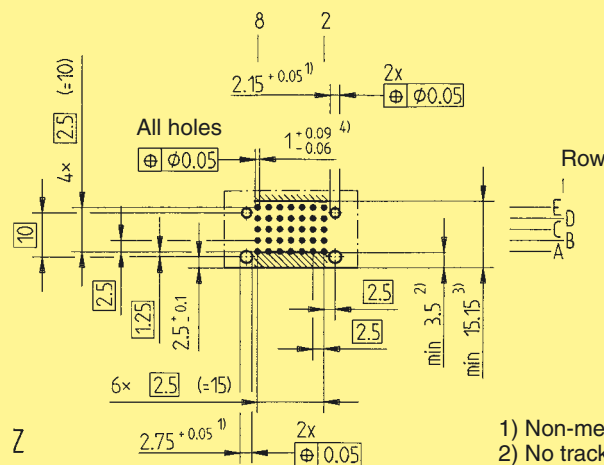

- 1) Non-metallised drillings
- 2) No tracks, except solder eyes
- 3) Limit area of components (valid for both pcb-sides)
- 4) For press-in connection DIN EN 60 352-5

\* Contact arrangements see page 05.03

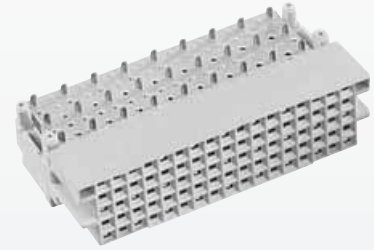

Female connectors, angled

Identification	Number of contacts	Contact arrangement*	Part number
2 SU female connector with press-in termination	27	3	07 22 319 7015 <b>07 22 319 8015</b>
	43	2	07 22 219 7015 <b>07 22 219 8015</b>
	68	8	07 22 819 7015 <b>07 22 819 8015</b>
	85	1	07 22 119 7015 <b>07 22 119 8015</b>

Connector dimensions [mm]

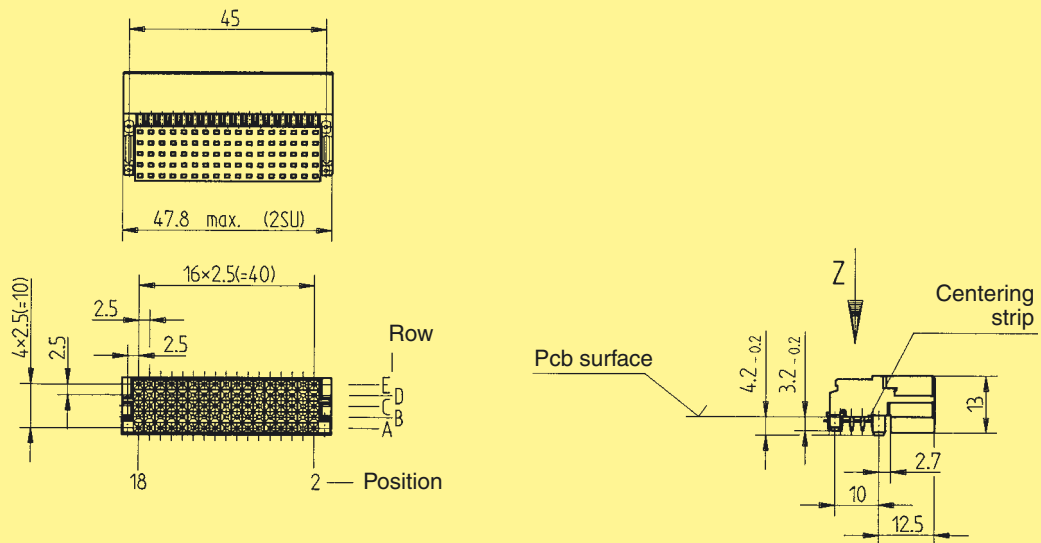

Board drillings (revolved by 90°)

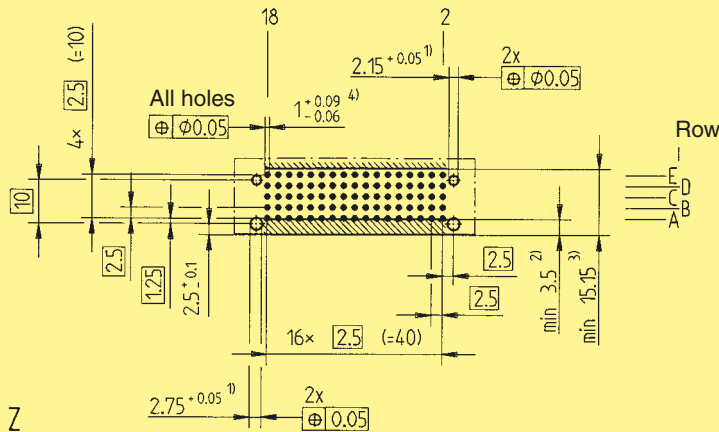

- 1) Non-metallised drillings
- 2) No tracks, except solder eyes
- 3) Limit area of components (valid for both pcb-sides)
- 4) For press-in connection DIN EN 60 352-5

\* Contact arrangements see page 05.03

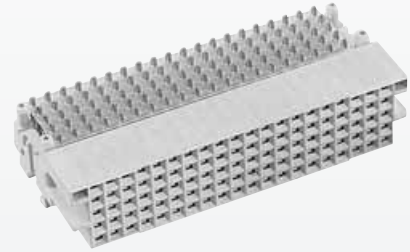

Female connectors, angled

Identification	Number of contacts	Contact arrangement*	Part number
2.3 SU female connector with press-in termination	30	3	07 22 319 7016 <b>07 22 319 8016</b>
	50	2	07 22 219 7016 <b>07 22 219 8016</b>
	80	8	07 22 819 7016 <b>07 22 819 8016</b>
	100	1	07 22 119 7016 <b>07 22 119 8016</b>

Connector dimensions [mm]

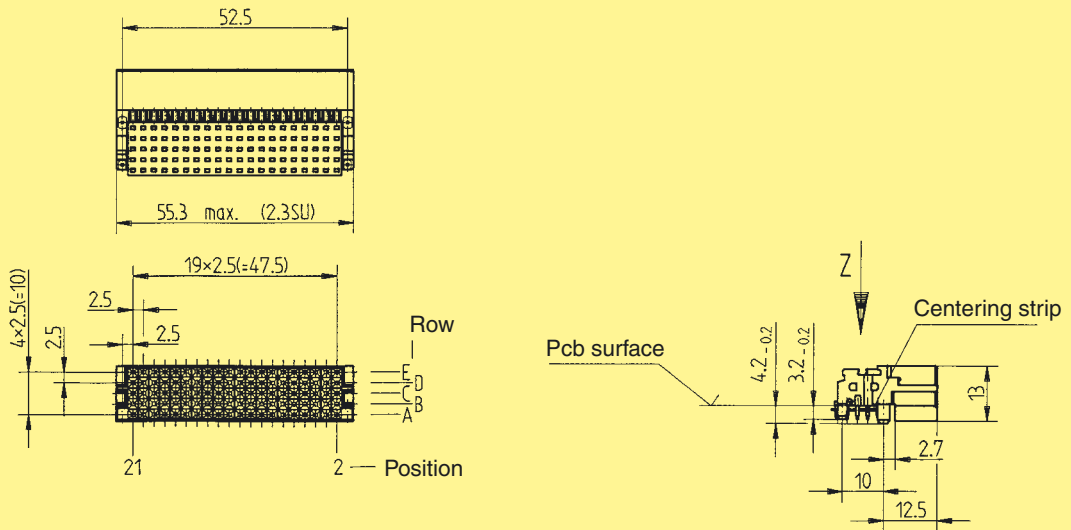

Board drillings (revolved by 90°)

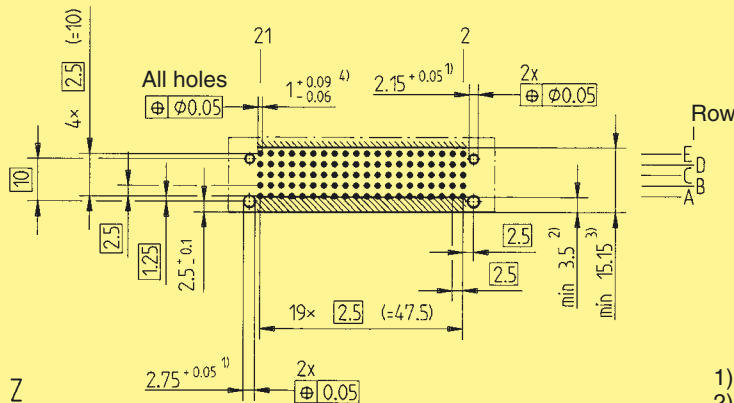

- 1) Non-metallised drillings
- 2) No tracks, except solder eyes
- 3) Limit area of components (valid for both pcb-sides)
- 4) For press-in connection DIN EN 60 352-5

\* Contact arrangements see page 05.03

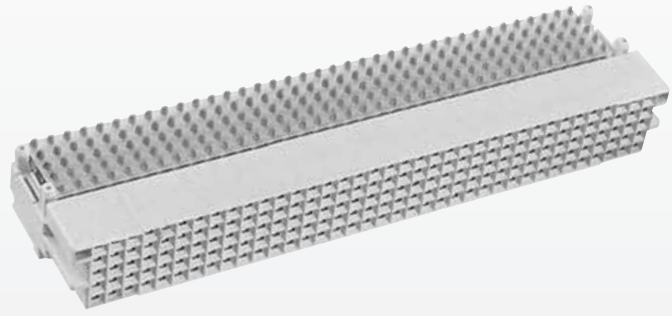

Female connectors, angled

Identification	Number of contacts	Contact arrangement*	Part number
4 SU female connector with press-in termination	57	3	07 24 319 7015 <b>07 24 319 8015</b>
	93	2	07 24 219 7015 <b>07 24 219 8015</b>
	148	8	07 24 819 7015 <b>07 24 819 8015</b>
	185	1	07 24 119 7015 <b>07 24 119 8015</b>

Connector dimensions [mm]

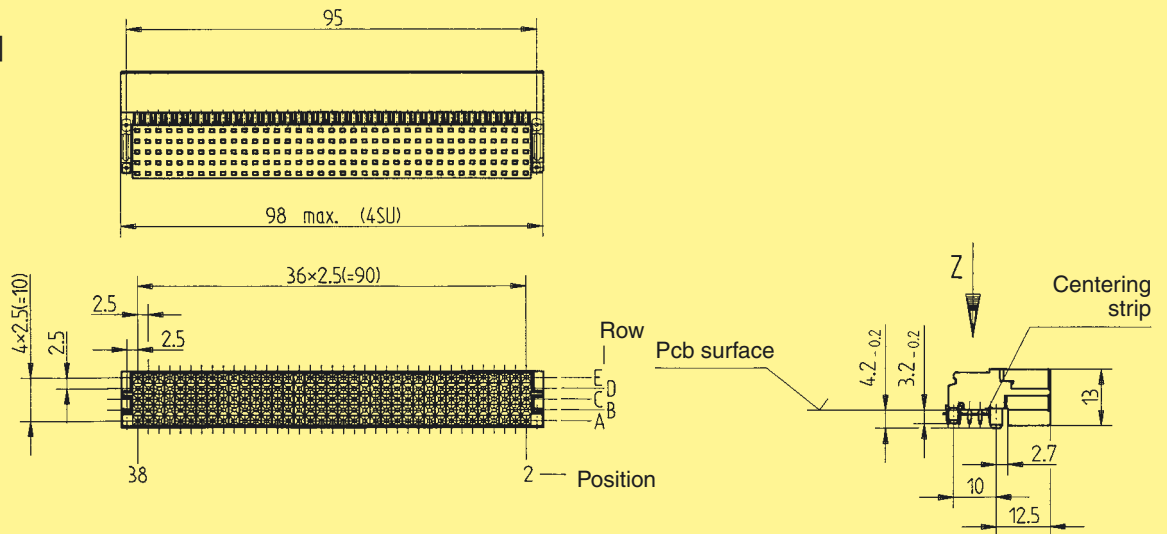

Board drillings (revolved by 90°)

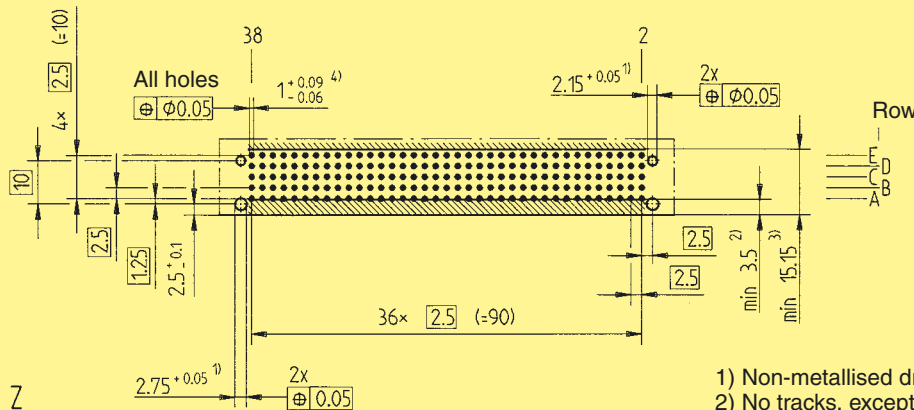

- 1) Non-metallised drillings
- 2) No tracks, except solder eyes
- 3) Limit area of components (valid for both pcb-sides)
- 4) For press-in connection DIN EN 60 352-5

\* Contact arrangements see page 05.03



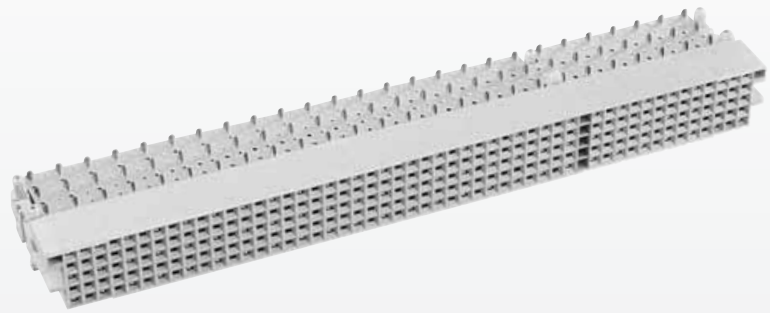

Female connectors, angled

Identification	Number of contacts	Contact arrangement*	Part number
5.4 SU female connector with press-in termination	78	3	07 25 319 7015 <b>07 25 319 8015</b>
	126	2	07 25 219 7015 <b>07 25 219 8015</b>
	200	8	07 25 819 7015 <b>07 25 819 8015</b>
	250	1	07 25 119 7015 <b>07 25 119 8015</b>

Connector dimensions [mm]

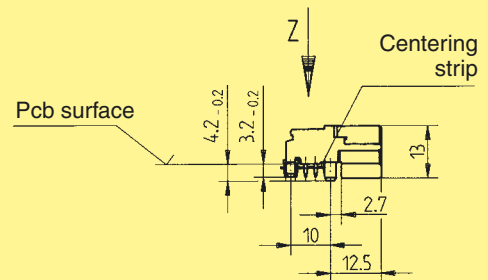
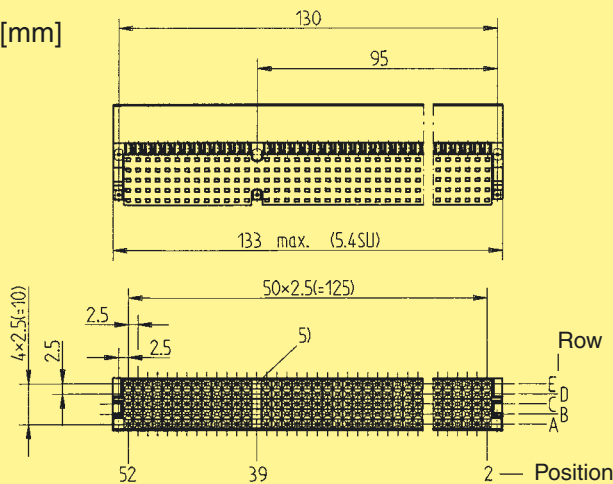

Board drillings (revolved by 90°)

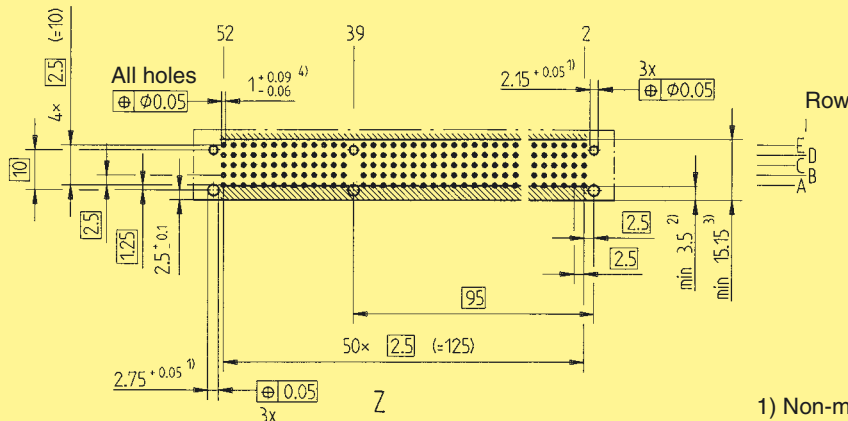

- 1) Non-metallised drillings
- 2) No tracks, except solder eyes
- 3) Limit area of components (valid for both pcb-sides)
- 4) For press-in connection DIN EN 60 352-5
- 5) Aperture for male contact

\* Contact arrangements see page 05.03

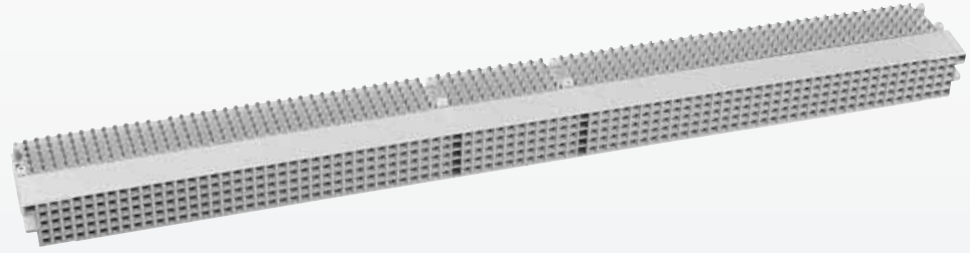

Female connectors, angled

Identification	Number of contacts	Contact arrangement*	Part number
9 SU female connector with press-in termination	132	3	07 29 319 7015 <b>07 29 319 8015</b>
	214	2	07 29 219 7015 <b>07 29 219 8015</b>
	340	8	07 29 819 7015 <b>07 29 819 8015</b>
	425	1	07 29 119 7015 <b>07 29 119 8015</b>

Connector dimensions [mm]

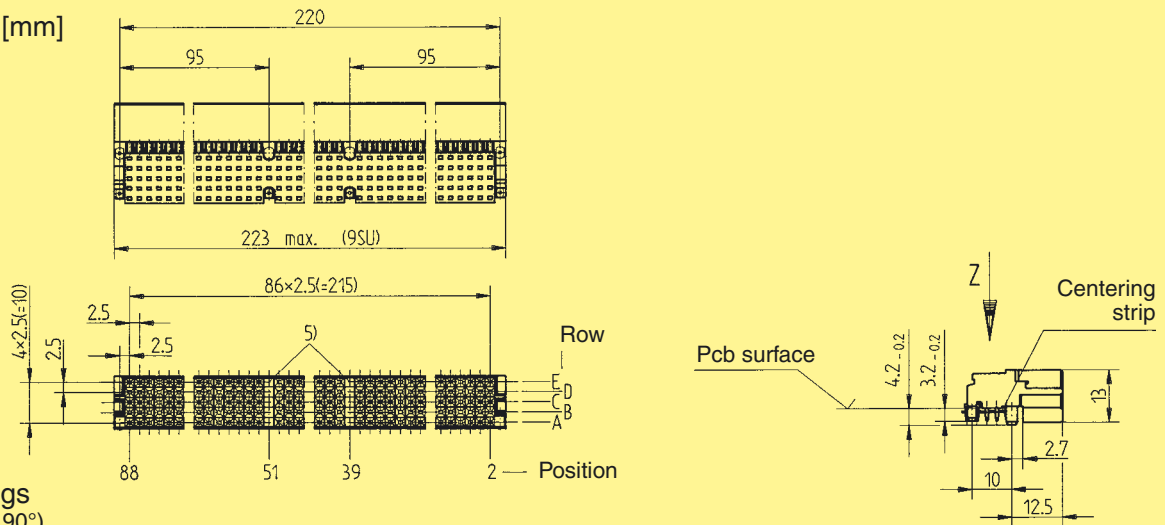

Board drillings (revolved by 90°)

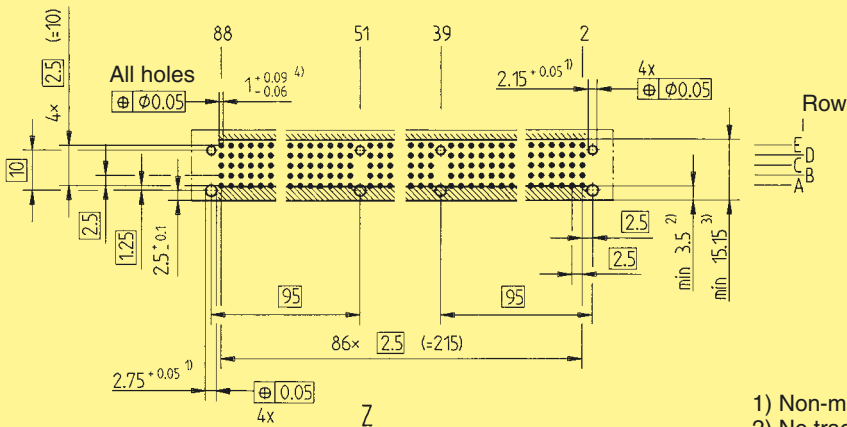

- 1) Non-metallised drillings
- 2) No tracks, except solder eyes
- 3) Limit area of components (valid for both pcb-sides)
- 4) For press-in connection DIN EN 60 352-5
- 5) Apertures for male contacts

\* Contact arrangements see page 05.03

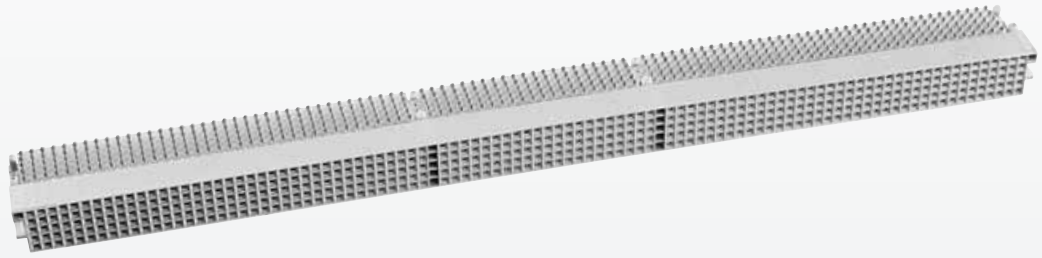

Female connectors, angled

Identification	Number of contacts	Contact arrangement*	Part number
10 SU female connector with press-in termination	147	3	07 20 319 7015 <b>07 20 319 8015</b>
	239	2	07 20 219 7015 <b>07 20 219 8015</b>
	380	8	07 20 819 7015 <b>07 20 819 8015</b>
	475	1	07 20 119 7015 <b>07 20 119 8015</b>

Connector dimensions [mm]

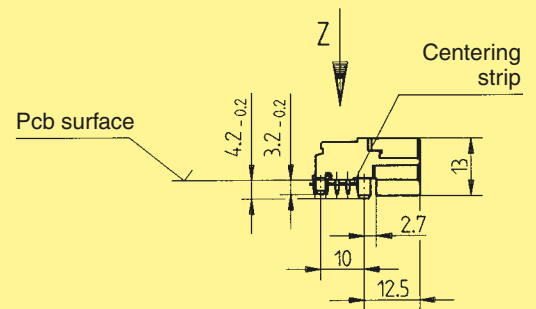
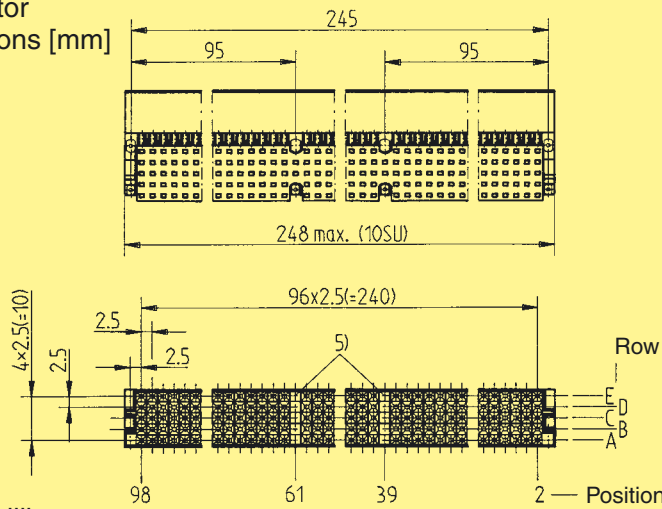

Board drillings (revolved by 90°)

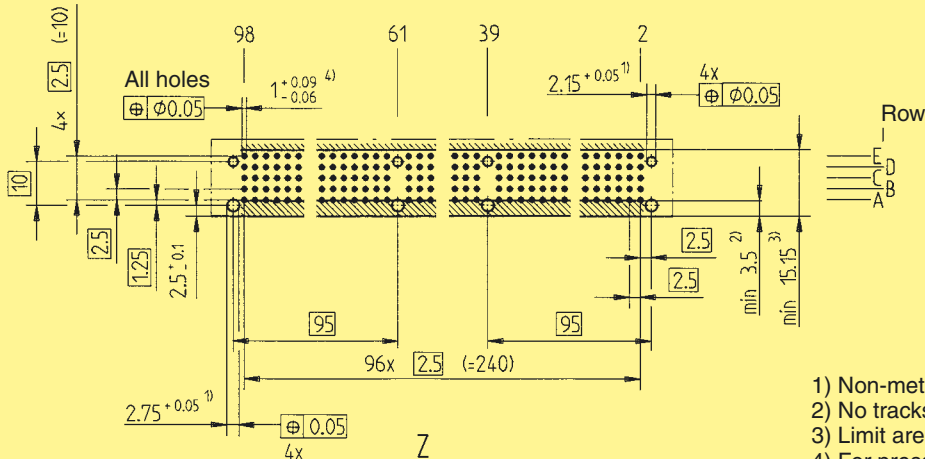

- 1) Non-metallised drillings
- 2) No tracks, except solder eyes
- 3) Limit area of components (valid for both pcb-sides)
- 4) For press-in connection DIN EN 60 352-5
- 5) Apertures for male contacts

\* Contact arrangements see page 05.03

Thin print part numbers: performance level 1  
**Bold print part numbers: performance level 2**

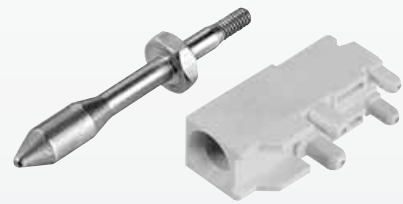

Identification

Guide pin

Receptacle for guide pin

Part number

07 73 000 0291

07 73 000 0280

Dimensions [mm]

Guide pin\*

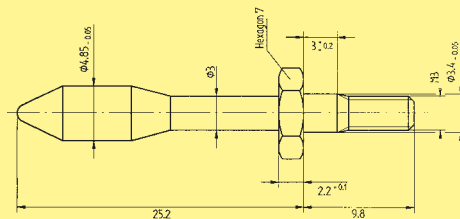

Receptacle for guide pin

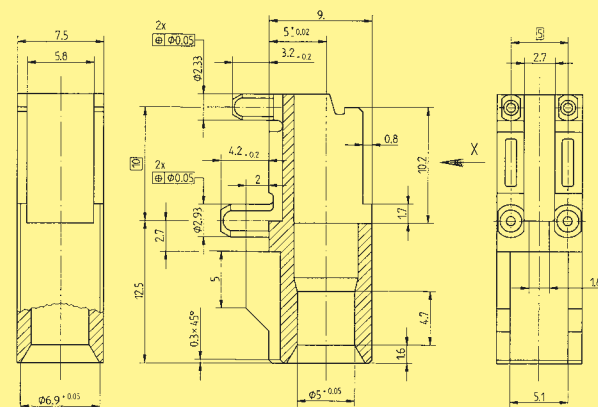

Board drillings (View-X)

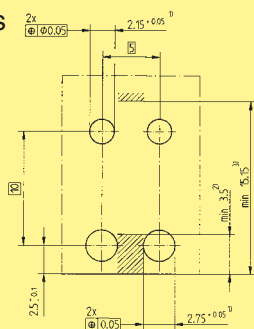

General information

The guide pin solution from HARTING allows safe mating under sometimes extreme conditions. This might be large and heavy boards that bow under their own weight. Also insufficiently aligned or worn out rack systems can be tolerated better with the use of HARTING's guiding system, which also reduces the potential danger of damaging cards when being forced into flexing racks.

The guide pin and receptacle's design solution allows to overcome a 3 mm [.118"] offset between the backplane and the mating daughtercard. The reducing diameter of the pin (from 4.85 mm to 3 mm) ensures that it's positioning task is smoothly transferred to the connectors as soon as they start to engage. Finally the thin diameter section of the guide pin is no longer positioned by the ferrule of the receptacle, ensuring that the pin is able to freely follow any movement imposed by the engaging connector. This ensures that there is no static stress between the connectors and the guiding system.

The rugged metal designed guide pin is screwed to the backplane with standard hexagon screws. Whereas the molded receptacle is designed with four press fit pegs that can be installed to the board together with the connectors.

The tooling can be ordered with the part numbers **0779 000 0157** (top tool) and **0779 000 0158** (bottom tool).

- 1) Non-metallised drillings
- 2) No tracks, except solder eyes
- 3) Limit area of components (valid for both pcb sides)

\* Recommended board drilling is 3.5 (-0.05) mm