



LITEMAX CM1236E

Sunlight readable 12.1" LED B/L LCD

(1st Edition 8/14/2007)

All information is subject to change without notice.

Approved by	Checked by	Prepared by
David	Sharline	Eric

LITEMAX Electronics Inc.
8F-2, No.133, Lane 235, Bau-chiau Rd.,
Shin-dian City, Taipei County, Taiwan R.O.C.
Tel : 886-2-8919-1858
Fax: 886-2-8919-1300
Homepage: <http://www.litemax.com.tw>

- CONTENTS -

REVISION HISTORY	-----	3
1. GENERAL DESCRIPTION	-----	4
1.1 OVERVIEW		
1.2 FEATURES		
1.3 APPLICATION		
1.4 GENERAL SPECIFICATIONS		
1.5 MECHANICAL SPECIFICATIONS		
2. ABSOLUTE MAXIMUM RATINGS	-----	6
2.1 ABSOLUTE RATINGS OF ENVIRONMENT		
2.2 ELECTRICAL ABSOLUTE RATINGS		
2.2.1 TFT LCD MODULE		
2.2.2 BACKLIGHT UNIT		
3. ELECTRICAL CHARACTERISTICS	-----	8
3.1 TFT LCD MODULE		
3.2 BACKLIGHT UNIT		
3.3 Power Consumption		
4. BLOCK DIAGRAM	-----	11
4.1 TFT LCD MODULE		
4.2 BACKLIGHT UNIT		
5. INPUT TERMINAL PIN ASSIGNMENT	-----	12
5.1 TFT LCD MODULE		
5.2 BACKLIGHT UNIT		
5.3 TIMING DIAGRAM OF LVDS INPUT SIGNAL		
5.4 COLOR DATA INPUT ASSIGNMENT		
6. INTERFACE TIMING	-----	14
6.1 INPUT SIGNAL TIMING SPECIFICATIONS		
6.2 POWER ON/OFF SEQUENCE		
7. OPTICAL CHARACTERISTICS	-----	16
7.1 TEST CONDITIONS		
7.2 OPTICAL SPECIFICATIONS		
8. PRECAUTIONS	-----	20
8.1 ASSEMBLY AND HANDLING PRECAUTIONS		
8.2 SAFETY PRECAUTIONS		
9. MECHANICAL CHARACTERISTICS	-----	21
10. LED DRIVER BOARD	-----	22

REVISION HISTORY

Version	Date	Section	Description
Ver. 0.0	Jan.,13 '06	-	CM-1236E Tentative Specification was first issued.
Ver. 1.0	June.,5 '06	-	CM-1236E Preliminary Specification was first issued.
Ver. 1.1	Oct.,04 '06	-	CM-1236E Approval Specification was first issued.

1. GENERAL DESCRIPTION

1.1 OVERVIEW

The LF-1236E model is a 12.1" TFT-LCD module with a 60-LED Backlight Unit and a 20-pin 1ch-LVDS interface. This module supports 1024 x 768 XGA mode and displays 262,144 colors.

1.2 FEATURES

- Wide viewing angle
- High contrast ratio
- Fast response time
- High color saturation
- XGA (1024 x 768 pixels) resolution
- Wide operating temperature
- DE (Data Enable) mode
- LVDS (Low Voltage Differential Signaling) interface
- RoHS Compliance
- High Brightness(1000nits)

1.3 APPLICATION

- TFT LCD Monitor
- TFT LCD TV
- Factory Application
- Amusement
- Vehicle

1.4 GENERAL SPECIFICATIONS

Item	Specification	Unit	Note
Diagonal Size	(12.1" diagonal)	mm	(1)
Active Area	245.76(H) x 184.32(V)	mm	
Bezel Opening Area	249.00(H) x 188.00(V)	mm	
Driver Element	a-si TFT active matrix	-	-
Pixel Number	1024 x R.G.B. x 768	pixel	-
Pixel Pitch	0.240(H) x 0.240(V)	mm	-
Pixel Arrangement	RGB vertical stripe	-	-
Display Colors	262,144	color	-
Transmissive Mode	Normally black	-	-
Surface Treatment	Hard coating (3H), Anti-glare (Haze 25%)	-	-

1.5 MECHANICAL SPECIFICATIONS

Item		Min.	Typ.	Max.	Unit	Note
Module Size	Horizontal (H)	271.5	272.0	272.5	mm	(1)
	Vertical (V)	203.5	204.0	204.5	mm	
	Depth (D)	9.2	9.7	10.2	mm	
Weight		-	-	752	g	-
I/F connector mounting position		The mounting inclination of the connector makes the screen center within $\pm 0.5\text{mm}$ as the horizontal.				(2)

Note (1) Please refer to the attached drawings for more information of front and back outline dimensions.

(2) Connector mounting position

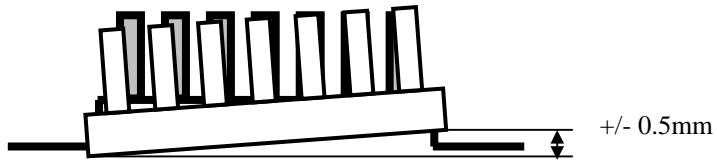

2. ABSOLUTE MAXIMUM RATINGS

2.1 ABSOLUTE RATINGS OF ENVIRONMENT

Item	Symbol	Value		Unit	Note
		Min.	Max.		
Operating Ambient Temperature	T _{OP}	-20	+60	°C	(0), (1), (2)
Storage Temperature	T _{ST}	-40	+80	°C	(0), (1)

Test Item	Test Condition	Note
High Temperature Storage Test	80°C, 240 hours	(1) (2)
Low Temperature Storage Test	-40°C, 240 hours	
Thermal Shock Storage Test	-40°C, 0.5hour 80 , 0.5hour; 100cycles, 1hour/cycle	
High Temperature Operation Test	60°C, 240 hours	
Low Temperature Operation Test	-20°C, 240 hours	
High Temperature & High Humidity Operation Test	60°C, RH 50%, 240hours	
Heat Cycle Operation Test	-20°C, 1hour 60°C, 1hour; 50cycles, 4hour/cycle	
ESD Test (Operation)	150pF, 330 , 1sec/cycle Condition 1 : panel contact, ±8KV Condition 2 : panel non-contact ±15KV	(2)
Shock (Non-Operating)	220G, 2ms, half sine wave, 1 time for ± X, ± Y, ± Z.	(2)(3)
Vibration (Non-Operating)	1.5G, 10 ~ 300 Hz, 10min/cycle, 3 cycles each X, Y, Z	(2)(3)

2.2 ELECTRICAL ABSOLUTE RATINGS

2.2.1 TFT LCD MODULE

Item	Symbol	Value		Unit	Note
		Min.	Max.		
Power Supply Voltage	V _{CC}	-0.3	4.0	V	(1)
Logic Input Voltage	V _{IN}	-0.3	2.7	V	

2.2.2 BACKLIGHT UNIT

Item	Symbol	Value		Unit	Note
		Min.	Max.		
LED Voltage	V _L	-	17.7	V _{RMS}	(1), (2), I _L = 1.1A
LED Current	I _L	0.05	1.1		(1), (2)

Note (1) Permanent damage to the device may occur if maximum values are exceeded. Function operation should be restricted to the conditions described under Normal Operating Conditions.

Note (2) Specified values are for LED (Refer to 3.2 for further information).

3. ELECTRICAL CHARACTERISTICS

3.1 TFT LCD MODULE

Ta = 25 ± 2 °C

Parameter	Symbol	Value			Unit	Note
		Min.	Typ.	Max.		
Power Supply Voltage	V _{CC}	3.0	3.3	3.6	V	-
Ripple Voltage	V _{RP}			100	mV	-
Rush Current	I _{RUSH}			1.0	A	(2)
Power Supply Current	White		(400)		mA	(3)a
	Black		(730)		mA	(3)b
LVDS differential input voltage	V _{id}	-100		+100	mV	
LVDS common input voltage	V _{ic}		1.2		V	

Note (1) The module is recommended to operate within specification ranges listed above for normal function.

Note (2) Measurement Conditions:

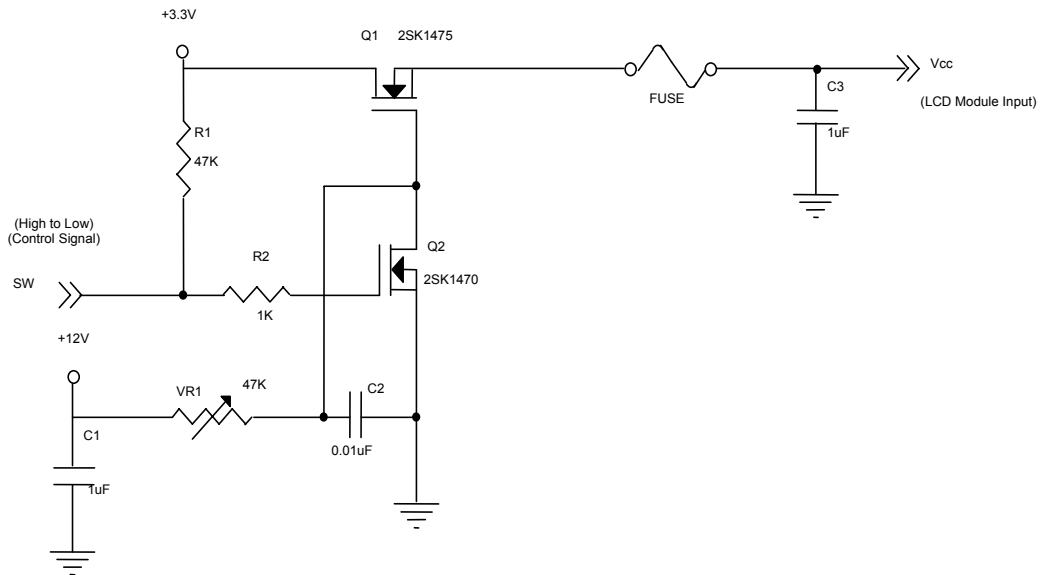

Vcc rising time is 470µs

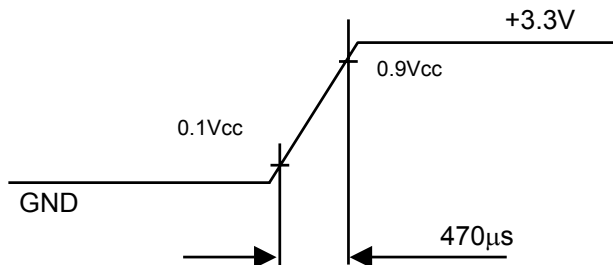

Note (3) The specified power supply current is under the conditions at $V_{cc} = 3.3\text{ V}$, $T_a = 25 \pm 2\text{ }^\circ\text{C}$, $f_v = 60\text{ Hz}$, whereas a power dissipation check pattern below is displayed.

a. White Pattern

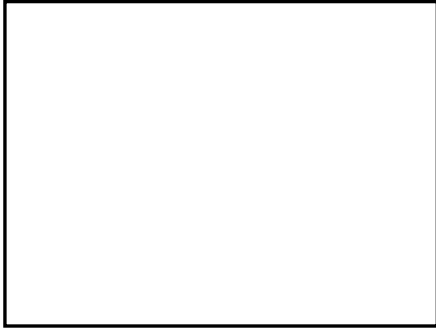

Active Area



3. ELECTRICAL CHARACTERISTICS

3.1 TFT LCD MODULE

Ta = 25 ± 2 °C

Parameter	Symbol	Value			Unit	Note
		Min.	Typ.	Max.		
Power Supply Voltage	V _{CC}	3.0	3.3	3.6	V	-
Ripple Voltage	V _{RP}			100	mV	-
Rush Current	I _{RUSH}			1.0	A	(2)
Power Supply Current	White		(400)		mA	(3)a
	Black		(730)		mA	(3)b
LVDS differential input voltage	V _{id}	-100		+100	mV	
LVDS common input voltage	V _{ic}		1.2		V	

Note (1) The module is recommended to operate within specification ranges listed above for normal function.

Note (2) Measurement Conditions:

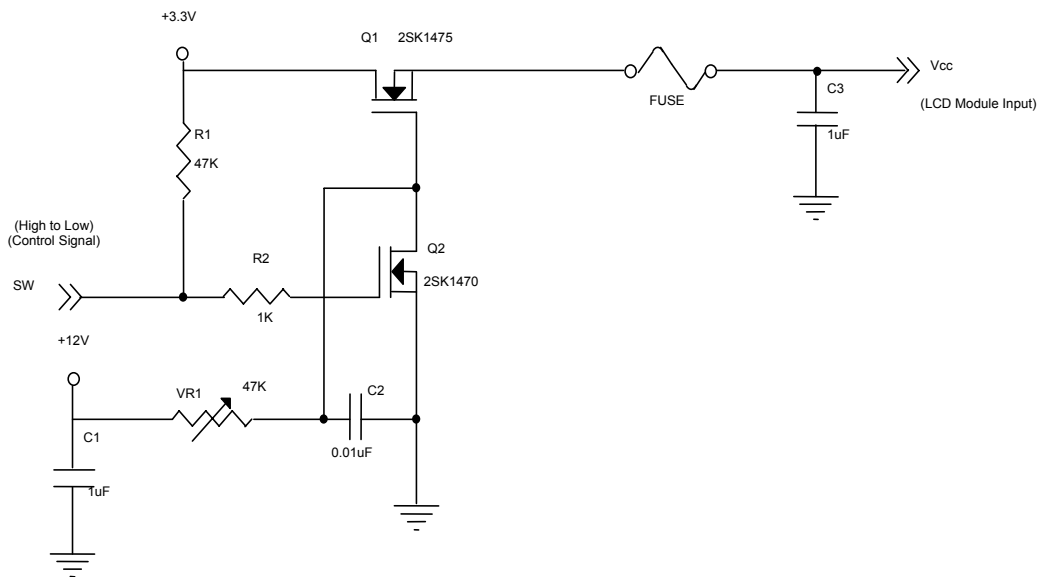

Vcc rising time is 470μs

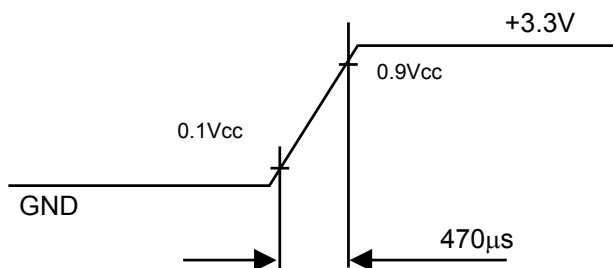

4. BLOCK DIAGRAM

4.1 TFT LCD MODULE

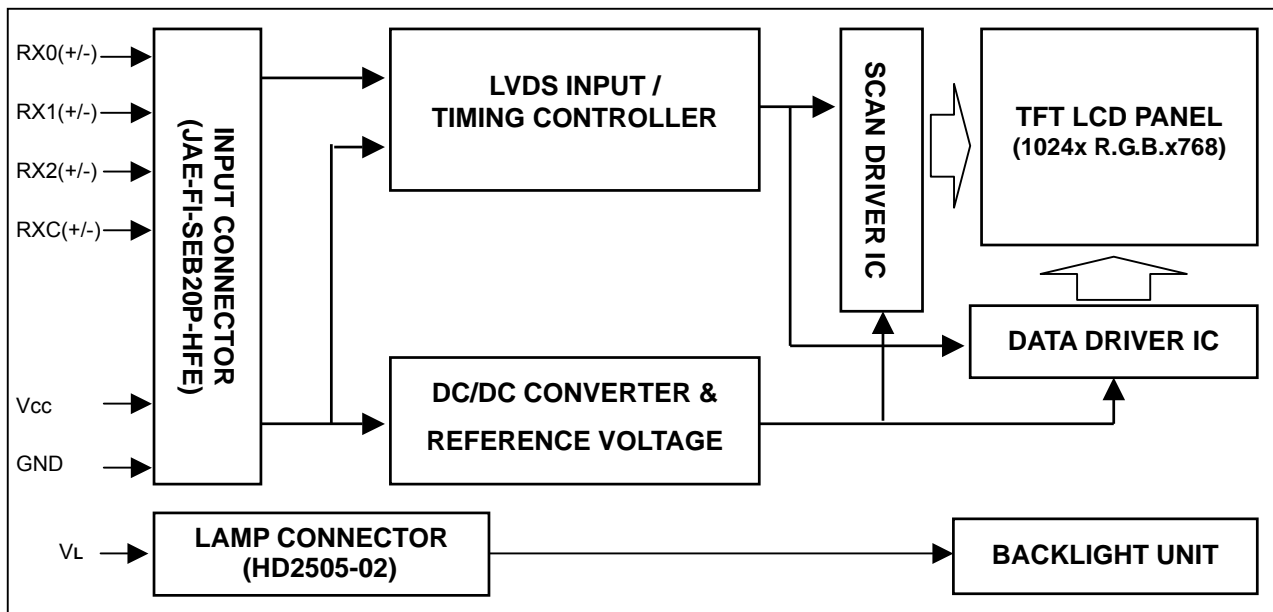

4.2 BACKLIGHT UNIT

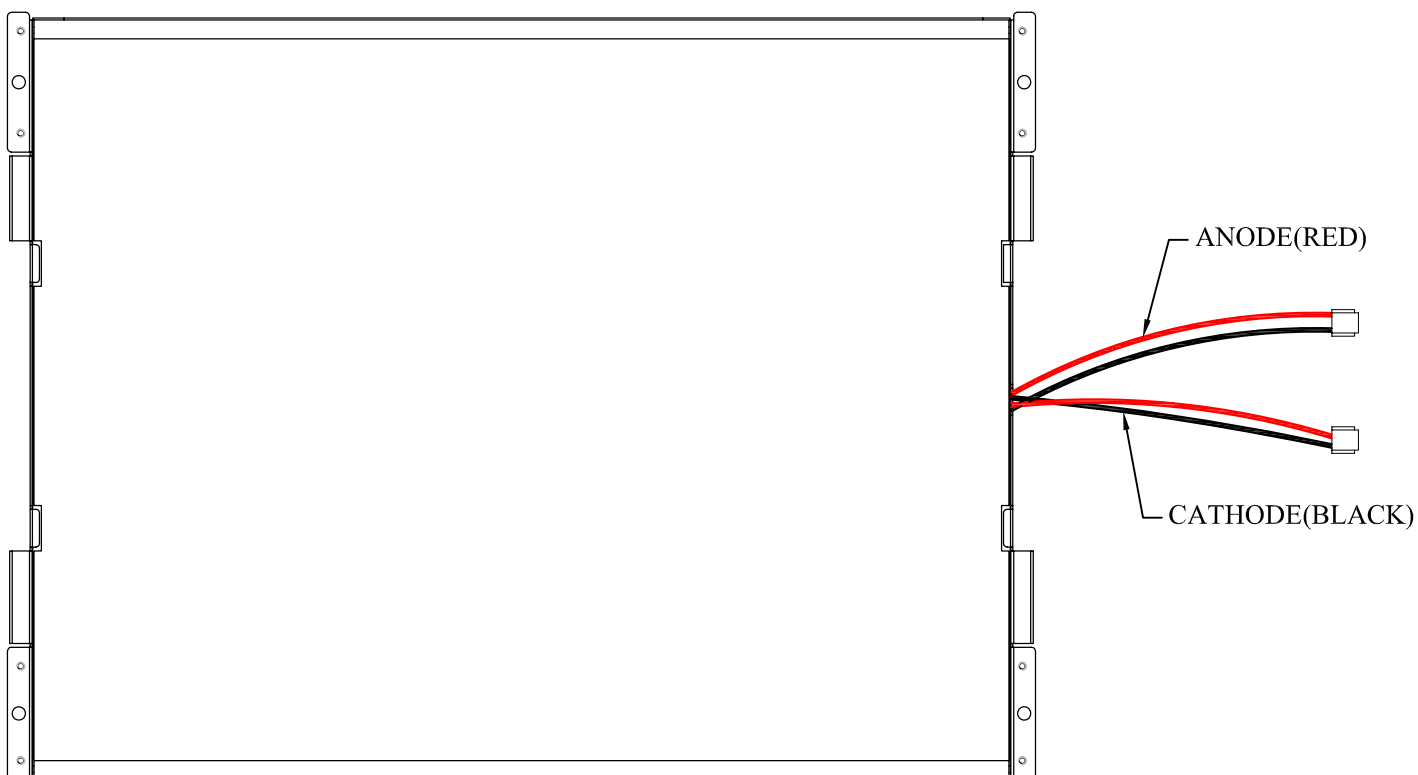

5. INPUT TERMINAL PIN ASSIGNMENT

5.1 TFT LCD MODULE

Pin	Name	Description	Remark
1	VCC_IN	Power Supply (5.0 V / 3.3 V)	
2	VCC_IN	Power Supply (5.0 V / 3.3 V)	
3	GND	Ground	
4	GND	Ground	
5	RX0-	Differential Data Input, CH0 (Negative)	R0 ~ R5, G0
6	RX0+	Differential Data Input, CH0 (Positive)	
7	GND	Ground	
8	RX1-	Differential Data Input, CH1 (Negative)	G1 ~ G5, B0, B1
9	RX1+	Differential Data Input , CH1 (Positive)	
10	GND	Ground	
11	RX2-	Differential Data Input , CH2 (Negative)	B2 ~ B5, DE, Hsync, Vsync
12	RX2+	Differential Data Input , CH2 (Positive)	
13	GND	Ground	
14	CLK-	Differential Clock Input (Negative)	LVDS Level Clock
15	CLK+	Differential Clock Input (Positive)	
16	GND	Ground	
17	NA	Non-connection	
18	NA	Non-connection	
19	GND	Ground	
20	GND	Ground	

Note (1) Connector Part No.: JAE-FI-SEB20P-HFE or equivalent.

Note (2) Mating Connector Part No.: JAE-FI-SE20M, FI-S20S or equivalent.

Note (3) The first pixel is odd.

Note (4) Input signal of even and odd clock should be the same timing.

5.2 BACKLIGHT UNIT

Pin	Symbol	Description	Remark
1	P+	Anode	Red
2	P-	Cathode	Black

Note (1) Connector Part No.: HD2505-02 or equivalent

Note (2) User's connector Part No.: TD2505-02 or equivalent

5.3 COLOR DATA INPUT ASSIGNMENT

The brightness of each primary color (red, green and blue) is based on the 6-bit gray scale data input for the color. The higher the binary input, the brighter the color. The table below provides the assignment of color versus data input.

Color		Data Signal																	
		Red						Green						Blue					
		R5	R4	R3	R2	R1	R0	G5	G4	G3	G2	G1	G0	B5	B4	B3	B2	B1	B0
Basic Colors	Black	0	0	0	0	0	0	0	0	0	0	0	0	0	0	0	0	0	0
	Red	1	1	1	1	1	1	0	0	0	0	0	0	0	0	0	0	0	0
	Green	0	0	0	0	0	0	1	1	1	1	1	1	0	0	0	0	0	0
	Blue	0	0	0	0	0	0	0	0	0	0	0	0	1	1	1	1	1	1
	Cyan	0	0	0	0	0	0	1	1	1	1	1	1	1	1	1	1	1	1
	Magenta	1	1	1	1	1	1	0	0	0	0	0	0	1	1	1	1	1	1
	Yellow	1	1	1	1	1	1	1	1	1	1	1	1	0	0	0	0	0	0
	White	1	1	1	1	1	1	1	1	1	1	1	1	1	1	1	1	1	1
Gray Scale Of Red	Red(0)/Dark	0	0	0	0	0	0	0	0	0	0	0	0	0	0	0	0	0	0
	Red(1)	0	0	0	0	0	1	0	0	0	0	0	0	0	0	0	0	0	0
	Red(2)	0	0	0	0	1	0	0	0	0	0	0	0	0	0	0	0	0	0
	:	:	:	:	:	:	:	:	:	:	:	:	:	:	:	:	:	:	:
	:	:	:	:	:	:	:	:	:	:	:	:	:	:	:	:	:	:	:
	:	:	:	:	:	:	:	:	:	:	:	:	:	:	:	:	:	:	:
	Red(61)	1	1	1	1	0	1	0	0	0	0	0	0	0	0	0	0	0	0
	Red(62)	1	1	1	1	1	0	0	0	0	0	0	0	0	0	0	0	0	0
Red(63)	1	1	1	1	1	1	0	0	0	0	0	0	0	0	0	0	0	0	
Gray Scale Of Green	Green(0)/Dark	0	0	0	0	0	0	0	0	0	0	0	0	0	0	0	0	0	0
	Green(1)	0	0	0	0	0	0	0	0	0	0	0	1	0	0	0	0	0	0
	Green(2)	0	0	0	0	0	0	0	0	0	0	1	0	0	0	0	0	0	0
	:	:	:	:	:	:	:	:	:	:	:	:	:	:	:	:	:	:	:
	:	:	:	:	:	:	:	:	:	:	:	:	:	:	:	:	:	:	:
	:	:	:	:	:	:	:	:	:	:	:	:	:	:	:	:	:	:	:
	Green(61)	0	0	0	0	0	0	1	1	1	1	0	1	0	0	0	0	0	0
	Green(62)	0	0	0	0	0	0	1	1	1	1	1	0	0	0	0	0	0	0
Green(63)	0	0	0	0	0	0	1	1	1	1	1	1	0	0	0	0	0	0	
Gray Scale Of Blue	Blue(0)/Dark	0	0	0	0	0	0	0	0	0	0	0	0	0	0	0	0	0	0
	Blue(1)	0	0	0	0	0	0	0	0	0	0	0	0	0	0	0	0	0	1
	Blue(2)	0	0	0	0	0	0	0	0	0	0	0	0	0	0	0	0	1	0
	:	:	:	:	:	:	:	:	:	:	:	:	:	:	:	:	:	:	:
	:	:	:	:	:	:	:	:	:	:	:	:	:	:	:	:	:	:	:
	:	:	:	:	:	:	:	:	:	:	:	:	:	:	:	:	:	:	:
	Blue(61)	0	0	0	0	0	0	0	0	0	0	0	0	1	1	1	1	0	1
	Blue(62)	0	0	0	0	0	0	0	0	0	0	0	0	1	1	1	1	1	0
Blue(63)	0	0	0	0	0	0	0	0	0	0	0	0	1	1	1	1	1	1	

6. INTERFACE TIMING

6.1 INPUT SIGNAL TIMING SPECIFICATIONS

The input signal timing specifications are shown as the following table and timing diagram.

Signal	Item	Symbol	Min.	Typ.	Max.	Unit	Note
DCLK	Frequency	Fc	57.5	64.9	74.4	MHz	
	Period	Tc	13.4	15.4	17.3	ns	
Vertical Active Display Term	Frame Rate	Fr	56	60	75	Hz	
	Total	Tv	774	806	848	Th	Tv=Tvd+Tvb
	Display	Tvd	768	768	768	Th	
	Blank	Tvb	Tv-Tvd	38	Tv-Tvd	Th	
Horizontal Active Display Term	Total	Th	1240	1344	1464	Tc	Th=Thd+Thb
	Display	Thd	1024	1024	1024	Tc	
	Blank	Thb	Th-Thd	320	Th-Thd	Tc	

Note : (1) Because this module is operated by DE only mode, Hsync and Vsync input signals should be set to low logic level or ground. Otherwise, this module would operate abnormally.

INPUT SIGNAL TIMING DIAGRAM

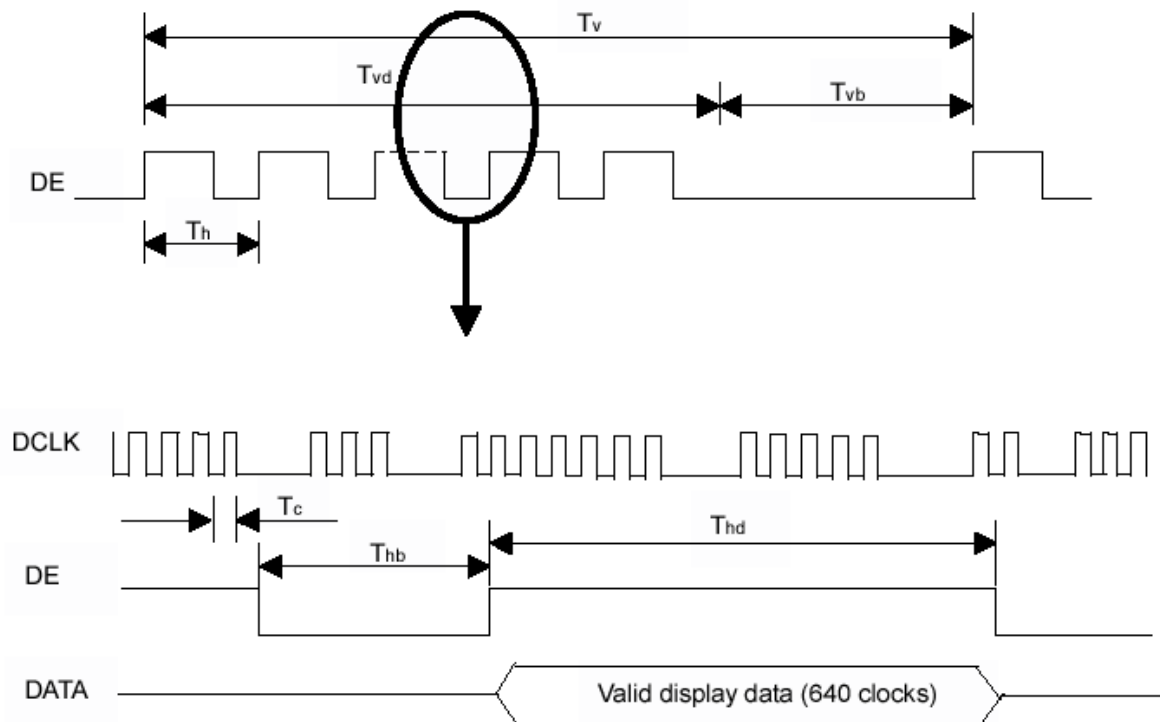

6.2 POWER ON/OFF SEQUENCE

To prevent a latch-up or DC operation of LCD module, the power on/off sequence should follow the conditions shown in the following diagram.

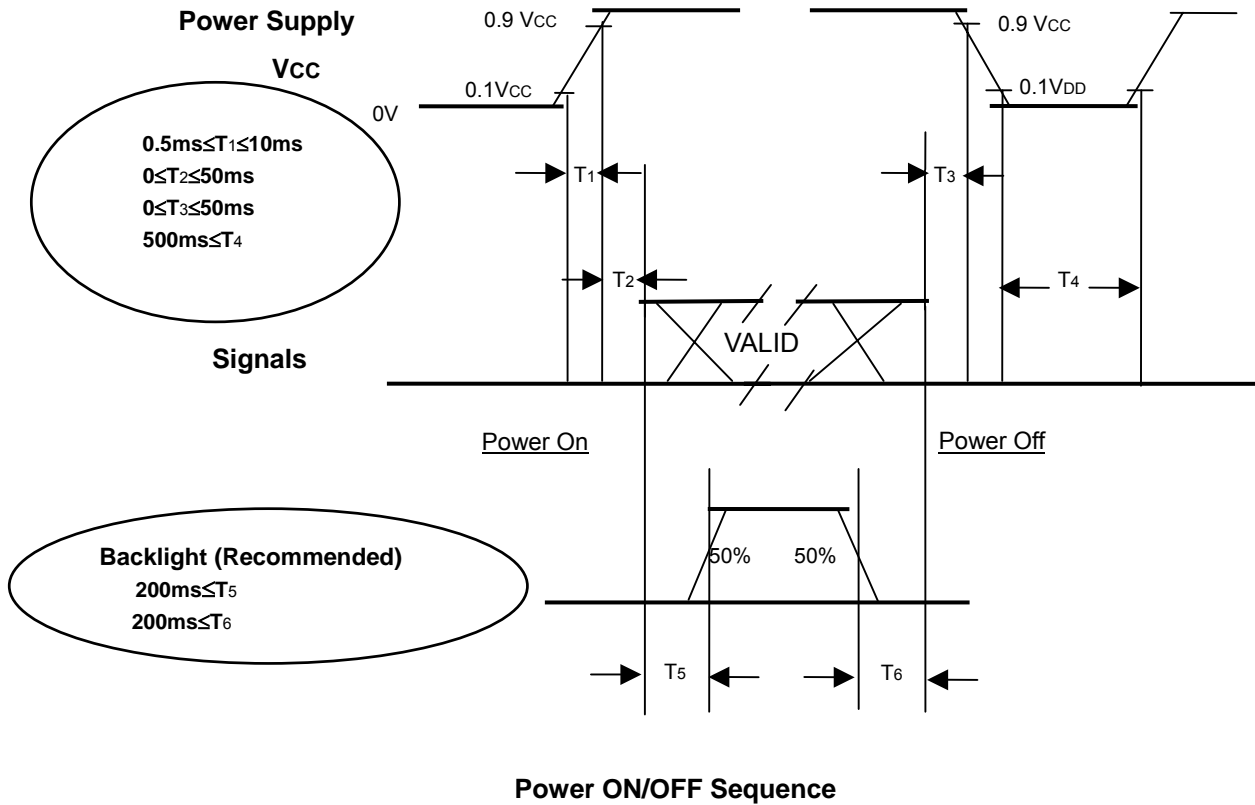

Note (1) Please avoid floating state of interface signal at invalid period.

Note (2) When the interface signal is invalid, be sure to pull down the power supply of LCD Vcc to 0 V.

Note (3) The Backlight power must be turned on after the power supply for the logic and the interface signal is valid. The Backlight power must be turned off before the power supply for the logic and the interface signal is invalid.

7. OPTICAL CHARACTERISTICS

7.1 TEST CONDITIONS

Item	Symbol	Value	Unit
Ambient Temperature	Ta	25±2	°C
Ambient Humidity	Ha	50±10	%RH
Supply Voltage	V _{CC}	5.0	V
Input Signal	According to typical value in "3. ELECTRICAL CHARACTERISTICS"		
LED Current	I _L	1.1	
LED Voltage	V _L		

7.2 OPTICAL SPECIFICATIONS

The relative measurement methods of optical characteristics are shown in 7.2. The following items should be measured under the test conditions described in 7.1 and stable environment shown in Note (5).

Item	Symbol	Condition	Min.	Typ.	Max.	Unit	Note			
Color Chromaticity	Red	$\theta_x=0^\circ, \theta_y=0^\circ$ BM-7					(1), (5)			
								Rx	(0.585)	-
	Ry							(0.365)	-	
	Green							Gx	(0.334)	-
								Gy	(0.519)	-
	Blue							Bx	(0.147)	-
								By	(0.144)	-
	White							Wx	(0.309)	-
Wy		(0.333)	-							
Center Luminance of White	L _C		(1030)		cd/m ²	(4), (5)				
Contrast Ratio	CR		(800)		-	(2), (5)				
Response Time	T _R	$\theta_x=0^\circ, \theta_y=0^\circ$					(3)			
	T _F							(6)	ms	
White Variation	δW	$\theta_x=0^\circ, \theta_y=0^\circ$					(5), (6)			
								(17)	ms	
Viewing Angle	Horizontal	CR≥10					(1), (5)			
								θ_{x+}	(65)	Deg.
	θ_{x-}							(75)		
	Vertical							θ_{y+}	(65)	
θ_{y-}		(75)								

Note (1) Definition of Viewing Angle (θ_x, θ_y):

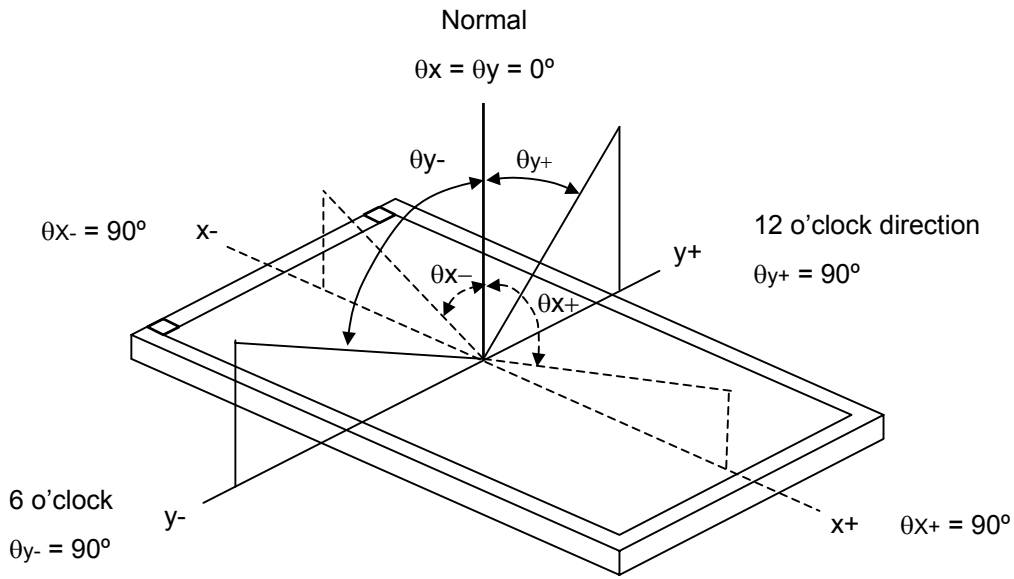

Note (2) Definition of Contrast Ratio (CR):

The contrast ratio can be calculated by the following expression.

$$\text{Contrast Ratio (CR)} = L_{63} / L_0$$

L63: Luminance of gray level 63

L 0: Luminance of gray level 0

$$CR = CR(5)$$

CR (X) is corresponding to the Contrast Ratio of the point X at Figure in Note (6).

Note (3) Definition of Response Time (T_R, T_F) and measurement method:

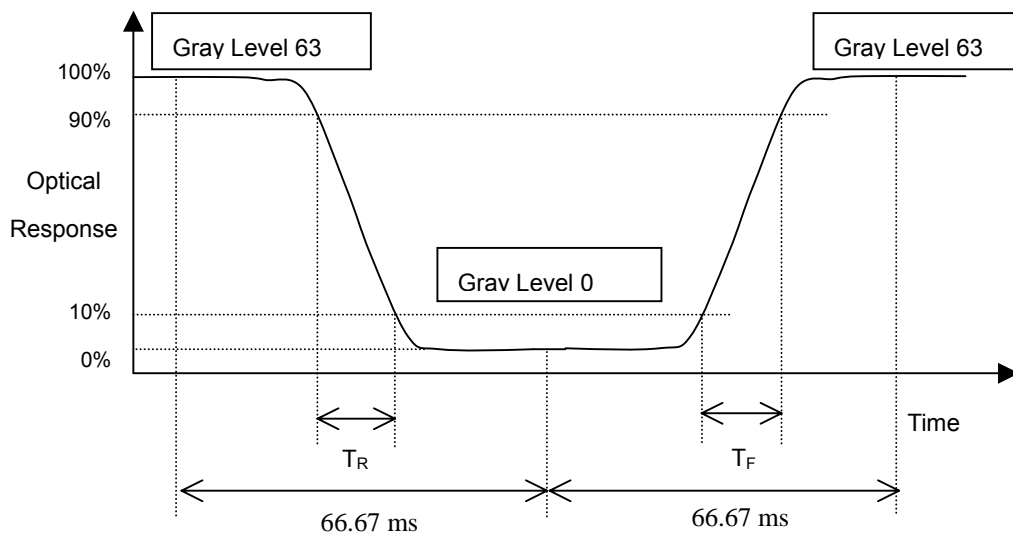

Note (4) Definition of Luminance of White (L_C):

Measure the luminance of gray level 63 at center point

$$L_C = L(5)$$

$L(x)$ is corresponding to the luminance of the point X at Figure in Note (6).

Note (5) Measurement Setup:

The LCD module should be stabilized at given temperature for 20 minutes to avoid abrupt temperature change during measuring. In order to stabilize the luminance, the measurement should be executed after lighting Backlight for 20 minutes in a windless room.

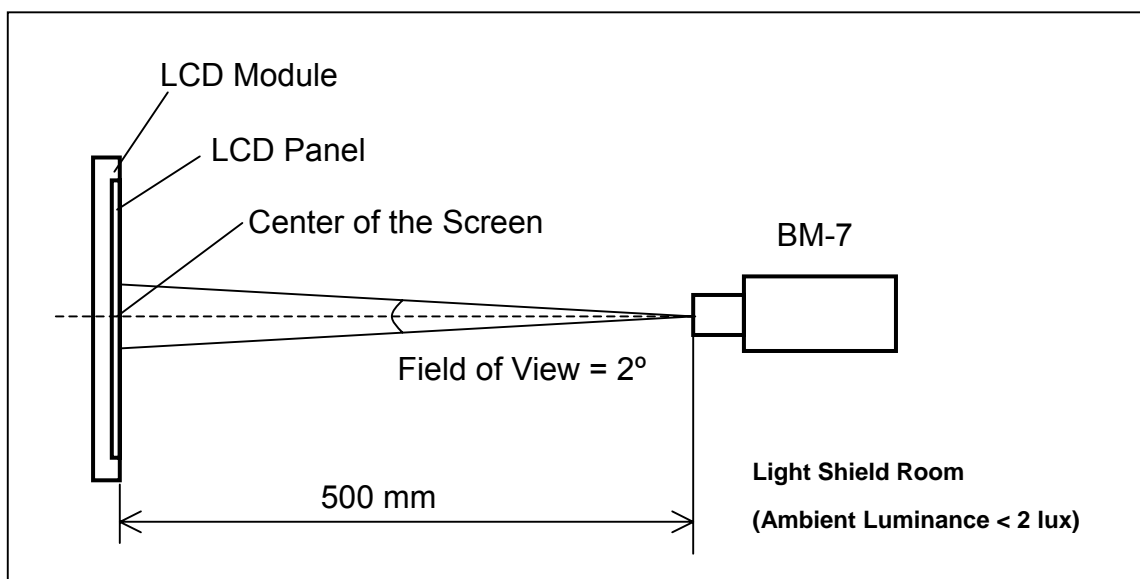

Note (6) Definition of White Variation (δW):

Measure the luminance of gray level 63 at 5 points

$$\delta W = \frac{\text{Maximum [L (1), L (2), L (3), L (4), L (5)]}}{\text{Minimum [L (1), L (2), L (3), L (4), L (5)]}}$$

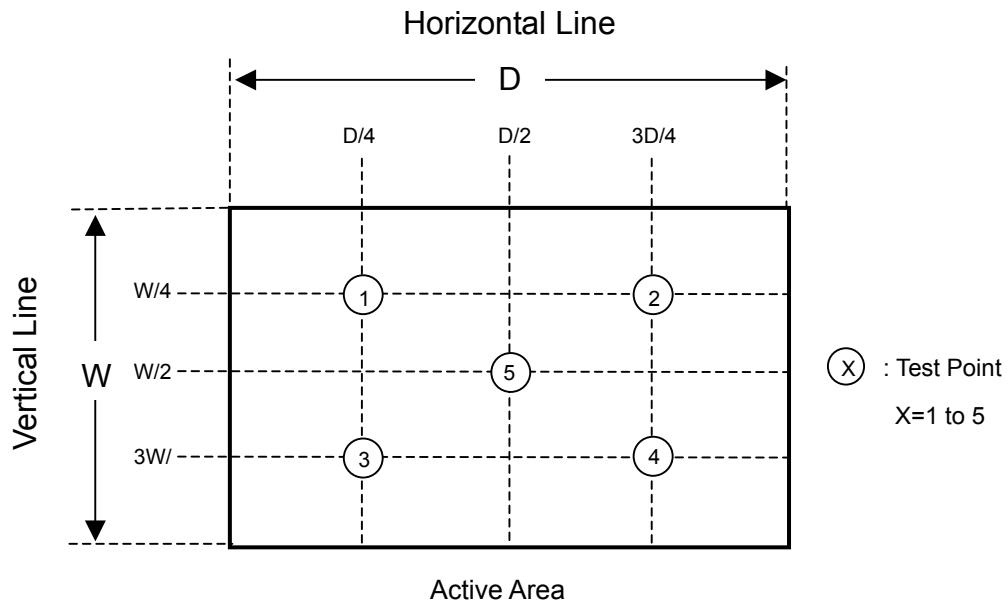

8. PRECAUTIONS

8.1 ASSEMBLY AND HANDLING PRECAUTIONS

- (1) Do not apply rough force such as bending or twisting to the module during assembly.
- (2) To assemble or install module into user's system can be only in clean working areas. The dust and oil may cause electrical short or worsen the polarizer.
- (3) It's not permitted to have pressure or impulse on the module because the LCD panel and Backlight will be damaged.
- (4) Always follow the correct power sequence when LCD module is connecting and operating. This can prevent damage to the CMOS LSI chips during latch-up.
- (5) Do not pull the I/F connector in or out while the module is operating.
- (6) Do not disassemble the module.
- (7) Use a soft dry cloth without chemicals for cleaning, because the surface of polarizer is very soft and easily scratched.
- (8) It is dangerous that moisture come into or contacted the LCD module, because moisture may damage LCD module when it is operating.
- (9) High temperature or humidity may reduce the performance of module. Please store LCD module within the specified storage conditions.
- (10) When ambient temperature is lower than 10°C may reduce the display quality. For example, the response time will become slowly, and the starting voltage of CCFL will be higher than room temperature.

8.2 SAFETY PRECAUTIONS

- (1) If the liquid crystal material leaks from the panel, it should be kept away from the eyes or mouth. In case of contact with hands, skin or clothes, it has to be washed away thoroughly with soap.
- (2) After the module's end of life, it is not harmful in case of normal operation and storage.

9. MECHANICAL CHARACTERISTICS

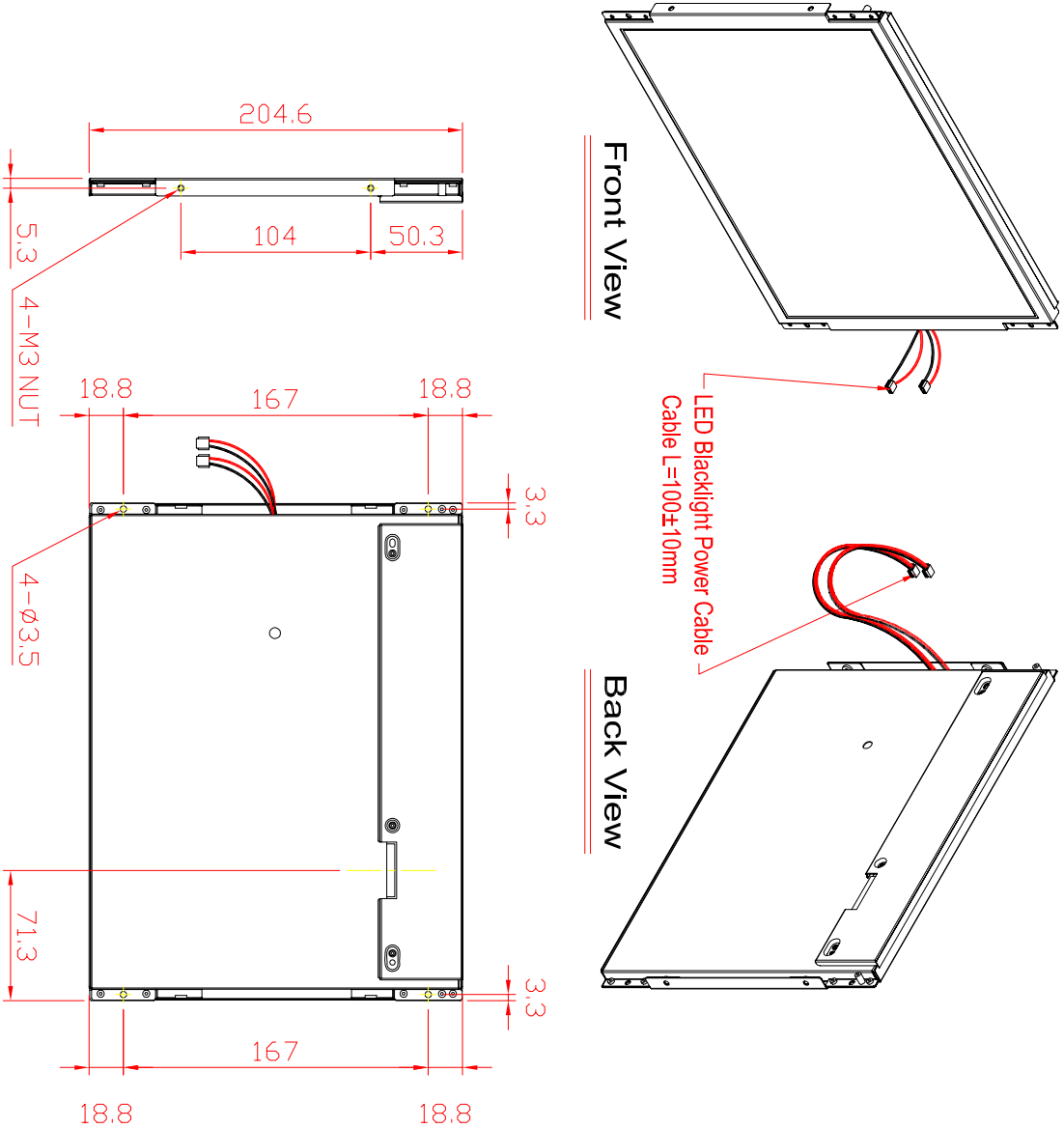
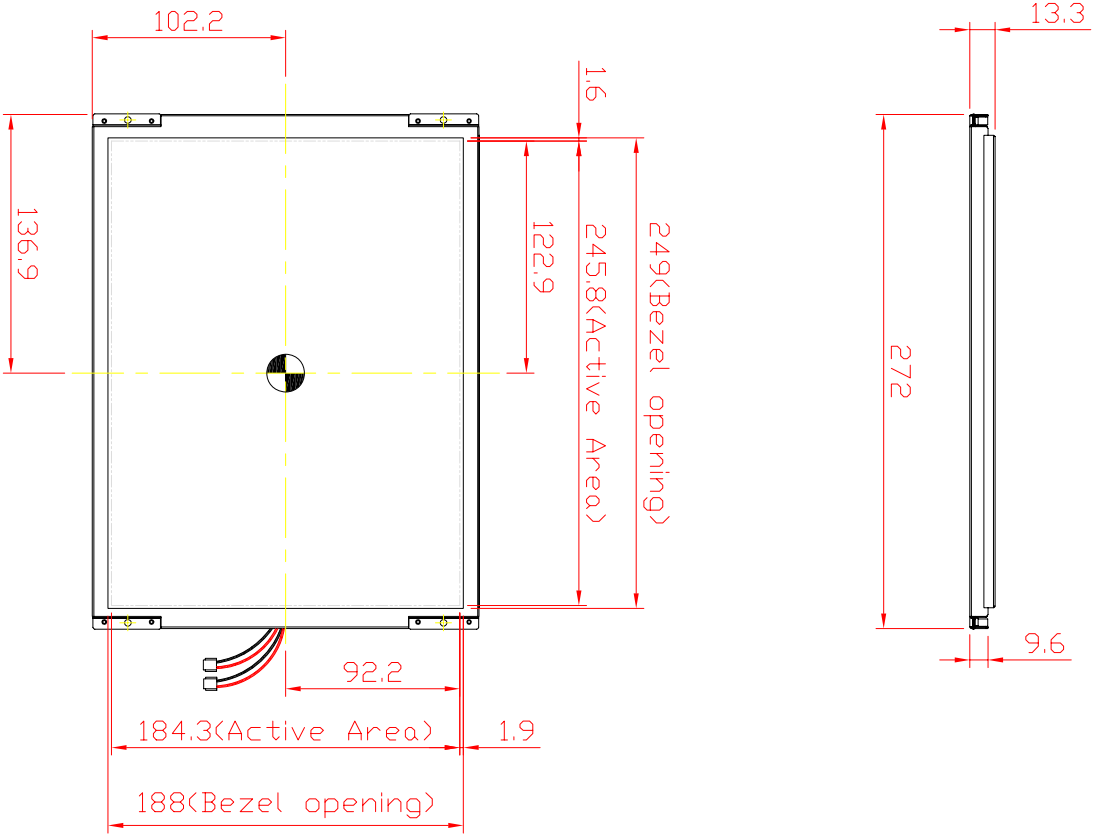

REV	ECN NO.	DESCRIPTION	SIGN	DATE
-	-	Design drawing		95.10.4

APPROVED	CHECKED	DESIGNED	LEVEL	General tolerance ±	SELECT LEVEL	MATERIAL	FINISH	OPTICAL DIMENSION	TITLE	UNIT	SCALE	WEIGHT	ANGLE	GENERAL TOLERANCE	3rd Angle	ORIGINAL MODEL
		Jacky_Kuo	0 ~ 4	0.05	0.1	0.2			CM-1236E	mm	1:4					CM-1236E
			4 ~ 14	0.1	0.3	0.5										
			14 ~ 63	0.2	0.6	1.2										
			63 ~ 250	0.3	0.8	2										
			250 ~ 600	0.5	1.2	3										
			600 ~ 4000													
									DRAWING NO(PART NO)							
									CM-1236E06(856CM1236E1P)							
									LiteMax							
									Electronic Inc.							
									SIZE							
									A4							
									SHT							
									1-1							
									REV							
									V1.1							