

LZS-A1000-3 POWER SUPPLY

Installation, Operation, and Maintenance Manual



IM-LZSA1000-3

September 2008

Revision G

TDK-Lambda

Table of Contents

1) Safety and Recommended Practices	2
1.1 General safety instructions	2
1.2 Safety Agency Approvals	2
2) RATINGS AND SPECIFICATIONS	4
3) FEATURES	5
4) GUIDE TO APPLICATION	7
4.1 Safety Notice	7
4.2 Input Voltage	7
4.3 Output Voltage	7
4.4 Overvoltage Protection Circuit Adjustment	7
4.5 Overtemperature and Overvoltage Shutdown	7
4.6 Auxiliary Control and Alarm Signals	7
5) FIGURES	8

1 Safety and Recommended Practices

1.1 General Safety Instructions

This power supply is a switch mode power supply for use in applications meeting a Pollution Degree 2 environment. A suitable mechanical and fire enclosure must be provided by the end use equipment for shock hazard protection, fire protection and protection from hazardous energy levels.



READ SAFETY INSTRUCTIONS carefully before working on the unit.



HIGH VOLTAGE WARNING: Dangerous voltages are present within the power supply.
NO USER SERVICEABLE PARTS INSIDE.

1. Do not install, test or operate this product near water, and do not spill any liquid on it.
2. Do not operate this product unless it is in a secure position.
3. This product must be installed and put into service by authorized competent personnel only who are fully conversant with the hazards of AC line operated equipment and with the particular dangers associated with switch mode power supplies.
4. This product is designed for use within other equipment or enclosures which restrict access to authorized competent personnel only and must not be user accessible.
5. This product must be reliably earthed and professionally installed in accordance with the prevailing electrical wiring regulations and safety standards. The product's PE connection is via the tapped standoff and screw on the front panel marked with IEC 60417-1 Symbol 5019.
6. The case is connected to the product's PE connection with screws. Therefore, screws at the case must not be removed or loosened.
7. The output power taken from the power supply must not exceed the rating stated on the power supply label.
8. Openings in the product case are designed for ventilation and must not be obstructed when the product is installed and/or operated.
9. Never push objects of any kind into the product through openings in its case as this could result in electric shock or fire hazard.
10. Use copper stranded wire only, 12 to 14 AWG rated at 105°C for the AC input. All strands must be secured in the terminal block to avoid potential danger of short circuit.
11. Properly torque AC input terminals to 9 in-lb.
12. An internal fuse protects the unit and must not be replaced by the user. In case of internal defect, the unit must be returned to the manufacturer.
13. The output of this power supply is hazardous and must not be user accessible in the end use equipment. The (+) or (-) output can be earthed. Use wire rated at 105°C and sized for 150% of the rated load.
14. The unit contains components that require special disposal. Make sure that the unit is properly disposed of at the end of its service life.

1.2 Safety Agency Approvals

Regulatory agency compliance applies only for operating frequencies between 47-63Hz.
No safety agency approvals for 100-380 VDC operation.

This product is approved to UL 60950-1/CAN CSA C22.2 No. 60950-1-03, First Edition, UL 508, Seventeenth Edition, EN 60950-1:2001, IEC 60950-1:2001, FM.

The CE Marking, when applied to the product, indicates conformance to the provisions of the following European Directives:

72/23/EEC Low Voltage Directive as amended by 93/68/EEC
89/336/EEC EMC Directive as amended by 92/31/EEC and 93/68/EEC

Emissions		
AC Line Conducted Emissions	EN55022/EN55011	(0.15-30 MHz) Class B
Radiated RF Emissions	EN55022/EN55011	30-1000 MHz Class B
Powerline Harmonics	EN61000-3-2	Class A Limits
Powerline Fluctuation/Flicker	EN61000-3-3	Complies
Immunity		
Electrostatic Discharge	IEC61000-4-2	+/-8 kV Air +/-6 kV Contact
RF Radiated Fields	IEC61000-4-3	10 V/m, 80 MHz-2.5GHz 80% AM @ 1kHz
Electrical Fast Transients	IEC61000-4-4	+/-2 kV AC Line, Criteria A +/-1 kV I/O Line > 3m, Criteria A
Lightning Surge	IEC61000-4-5	+/-2 kV line to GND (CM), Criteria A +/-1 kV line to line (DM), Criteria A
Conducted RF Common Mode	IEC61000-4-6	10 V/m RMS, 150 kHz-80 MHz 80% AM at 1kHz
Power Frequency Magnetic Field	IEC61000-4-8	3 A/m
Voltage Dips/Short Variations	IEC61000-4-11	5% of nom. line for .5 cycles - Criteria A 40% for 5 cycles - Criteria A 70% for 25 cycles - Criteria A 95% Dip for 5 seconds - Unit should not latch
	SEMI-F47 (100 VAC)	50% of nom. line for 200 msec 70% for 500 msec 80% for 10 seconds 90% for 15 seconds 0% for 1 cycle or 20mS
Additional Immunity		
Ring Wave Lightning Surge Test	IEEE C62.41	6 kV/30 Ohm Criteria A

Table 1

This manual is a description of specifications, features and applications of LZS-A1000 power supplies.

RATINGS AND SPECIFICATIONS *

Maximum Ratings		
	Units	LZS-A1000-3
Output Voltage Range	V	18-29.4
Output Current (Power) @ 60°C**	A(W)	42 (1008)
DC Output @ 24V		
Output Current (Power) @ 70°C**	A(W)	25.2 (605)
Operating Temperature	°C	47-63Hz 100% rated load from -30°C to 60°C derate linearly to 60% @ 70°C (4%/°C) Over 63Hz to 440Hz 100% rated load from -30°C to 55°C derate linearly to 60% @ 65°C (4%/°C)
Start-up Temperature	°C	-40° to +70°

Table 2

Input Specifications		
	Units	LZS-A1000-3
Input Voltage Range***	VAC VDC	85-265 (47-440Hz) Single Phase 100-380
Input Current (RMS, maximum)	A	20 RMS
Inrush Current (Peak, at cold start)	A	30A /110VAC; 40A / 220VAC
Power Factor Harmonics	-	EN61000-3-2 Compliant
Power Factor (at max output power)	-	0.99 typical @ 85VAC
Input Power (maximum)	W	1214W @ 42A (1008W) and 85VAC line
Input Surge Protection	-	1kV Differential Mode; 2kV common mode
Input EMI Conducted Emissions	-	FCC Class B, CISPR 22 Class B
Efficiency (at max.output power)	%	83 typical @ 110VAC line

Table 3

Output Performance Specifications		
	Units	LZS-A1000-3
Voltage Line Regulation	%	0.1
Voltage Load Regulation	%	0.1
Ripple and Noise @ 20 MHz measurement Bandwidth.	(PARD-mVP-P)	75
Temperature Coefficient	%/°C	.01
Startup Time (at 110 VAC input)	Sec.	Less than 1 second
Overshoot	mV	No overshoot at turn on or turn off
Holdup Time (Full Power/220VAC)	mS	10
Ride through (Full Power/220VAC)	mS	20
Voltage Sag Immunity (Full Power/110VAC)	-	Semi-F47 compliant
Load Transient Response (25% step load change)	-	+/-1% of Vo ; 1A/μS; Recovers to within +/-0.2% in < 1.25 mS

Table 4

- * Refer to figures 1-7 for supply-load connection information.
- ** Output current and power, as measured at output terminals, must be less than or equal to quoted maximum values for a given ambient temperature.
- *** Regulatory agency compliance applies only for operating frequencies between 47-63Hz. No safety agency approvals for 100-380 VDC operation. Minimum turn-ON voltage for DC Input is 110 VDC, unit will operate as low as 65 VDC after Power-up. Lambda doesn't recommend operation below 100 VDC for more than one minute, or damage may occur.

Operating Modes	
Series Operation	Yes (see Fig. 7)
Parallel Operation (with current sharing)	Two or more identical units (see Fig. 6). (Use of D. con. terminal 5 will provide current sharing to within 3% nominal of rated 40°C current.)

* Not backward compatible with the LZS-1000-3 power supply.

Table 5

FEATURES

DC Output Controls and Indicators	
Output Voltage Adjust	Screwdriver adjustment over entire range. Output voltage range is from 18-29.4V. (Multi-turn potentiometer accessible from terminal end of chassis.)
Overvoltage Protection Adjust	Screwdriver adjustment over entire range. Overvoltage trip range is from 20-34V. Factory setpoint is 31.0V. (Multi-turn potentiometer accessible from terminal end of chassis.)
Output Good Indicator	Green colored LED illuminates when output is within specified operating range
Fault Indicator	Red colored LED illuminates if overvoltage, overtemperature, or overcurrent shutdown occurs. The LED is also illuminated if the output is less than approximately 95% of its adjusted output or if the output is inhibited (stand-by mode).

Table 6

Remote Control Features	
Remote Voltage Sensing	Provides precise regulation directly at load (see Fig. 3). Maximum total DC voltage drop between output terminals and load must be limited to <1.0V. In addition, the voltage at the output terminals must be limited to 29.4V.
Remote Voltage Programming external resistor.	1000 ohms per volt for resistor connected between pins 1 and 2 on TB201 (see Figs. 4 and 5).
Remote Voltage Programming external voltage source.	Volt per volt for voltage source connected between pins 1 and 2 on TB201 (see Figs. 4 and 5).
Remote On/Off Control	Enable/Disable output via TTL compatible signal connected between pins 6 and 7 of "D" connector.
Signals Isolation	Pins 6 and 7 are fully isolated from all other power supply terminals.
Signal Logic	Logic zero (below 0.7 V), short circuit or open circuit disables power supply output. Logic one (above 2.5 V) enables power supply output.
Signal Current Draw	Current draw from Logic 1 input is less than 4mA.
Output Response Time	Output will be within specified limits within 100 ms. of application of logic "1" signal.
Signal Enable	Remote on/off function must be enabled by moving "OUTPUT ENABLE" switch at terminal end of chassis from "LOCAL" to "REMOTE" position.

Table 7

Auxiliary Monitoring and Alarm Signals	
Optically coupled, conductance outputs. (Conduct up to 1mA at a voltage of <0.4 V, when active.)	
Input Power Good Signal	Conductance signal which indicates adequate input capacitor voltage to provide 10 ms holdup time when operating -3 model at full output power. Signal will be asserted when the unit is remotely disabled (AC still present) or when unit shuts down due to overtemperature.
Output Good Alarm Signal	Conductance signal which indicates that delivered output voltage, as measured at the +V and -V terminals, is above its minimum specified value.
Inverter Good Signal	Conductance signal which indicates that the power supply's inverter is functional. At very light loads, this signal may be indeterminate.
Signal Isolation	Input power good, output UV/OV alarms, inverter good and remote on/off signals are isolated from power supply output and each other for voltages up to 500 volts, minimum. 3000 VAC isolation from AC input to all auxiliary signals.
Synchronization (Sync)	Auxiliary signal at approximately 200khz (switching frequency of unit) used for synchronizing with other equipment.

Table 8

Protection Features		
Output Voltage Range	V	18-29.4V
Nominal Factory Set Point	V	24V
Overvoltage Protection (adjustable)	V	20-34V (Factory set to 31.0V)
Overcurrent Protection	-	Factory set to 110% min. and 130% max.
Thermal Protection	-	Self-resetting thermostat.*
Fusing	-	Internal
Isolation Voltages	-	4242 VDC, Input to Output 2121 VDC, Input to Chassis Ground 500 VDC, Output to Chassis Ground
Regulatory Agency Compliance	-	UL 60950-1/CAN CSA C22.2 No. 60950-1-03, First Edition UL 508, Seventeenth Edition EN 60950-1:2001+A11, IEC 60950-1:2001, IEC61000 2nd Edition FM 3600, FM 3611, FM 3810, Semi F47
Leakage current (AC line to chassis ground)	μA	Less than 500 μA @ 265 VAC, 60 Hz

* See "Overtemperature and Overvoltage Shutdown" on page 7

Table 9

Mechanical Features		
	Units	
Storage Temperature (non-operating)	°C	-40°C - +85°C
Weight	lbs	8.1 lb net
Size	inches	5.62" x 4.75" x 10.5"
Finish	-	Textured gray - painted
Mounting	-	One mounting surface (mounting position not restricted) Maximum allowable penetration into power supply is 1/4". Requires No. M4 (metric) hardware - supplied with unit.)

Table 10

Input and Output Connections	
Input	Heavy duty terminal block
Chassis Ground	Tapped hole and screw provided in chassis.
DC Output	Heavy-duty bus bars with 1/4" clearance holes for load connections. (Connection hardware supplied with unit.)
Local/Remote voltage sensing, Remote on/off, Parallel operation.	Four-position lugless connector (TB201), see Fig. 1. (Accepts up to #14 AWG size stripped wire).
Auxiliary Control and Alarm Signals	Connections for remote and local sensing, remote on/off, parallel operation current sharing, input power good signal, OV alarm, UV alarm, inverter good signal and chassis are available via chassis mounted, 15-pin, female, sub-miniature "D" connector (see Fig. 1).

Table 11

Other Features	
Warranty	5 years
Cooling	Variable speed, Ball Bearing Fan
Fungus Inert	All LZS power supplies are inherently fungus inert.
Humidity	10%-90% Non-condensing
Altitude	0-10,000 Ft (Operating); 40,000 Ft (Non-Operating)

Table 12

4. GUIDE TO APPLICATION

4.1 SAFETY NOTICE

Dangerous voltages exist in this equipment. Observe the usual safety precautions when operating, wiring, or servicing to reduce the risk of shock or injury.

4.2 INPUT VOLTAGE

See Table 3 on page 4.

4.3 OUTPUT VOLTAGE

This power supply operates as a constant-voltage source with maximum load ratings as listed on page 4. If the load current tries to exceed 110% of the 60°C rating, the output voltage will begin to decrease, thereby limiting the power delivered to the load. Upon removal of overload, normal operation will resume.

When shipped from the factory, the power supply is ready for use with output voltage (V_{out}) set to its nominal rating of 24.0V. Jumpers are in place on TB201 for local voltage sensing. Where precise regulation is required directly at the load, remote voltage sensing can be utilized. This can be achieved by utilizing the remote sense terminals on TB201 or "D" connector (see Figs. 2 and 3). The output voltage can be increased by turning the V_{out} adjust potentiometer clockwise. The output voltage is decreased by turning the V_{out} adjust potentiometer counter clockwise.

As shown on page 4, LZS-A1000 power supplies have both a maximum current rating and a maximum output power rating (as a function of ambient temperature). Care should be taken to limit both output current and output power to be within specified limits. If these limitations are not adhered to, the internal thermal protection circuit may shut down the power supply's operation. For remote voltage sensing, the maximum limits for output power, as given on page 4, apply at the power supply output terminals, not at the remote sensing point.

When adjusting the output voltage above 24.0V, ensure that there is sufficient OVP margin with respect to the output voltage, to avoid nuisance tripping.

4.4 OVERVOLTAGE PROTECTION CIRCUIT ADJUSTMENT

The overvoltage protection circuit provides an adjustable means of disabling the DC output if it should exceed a pre-determined safe value. When shipped from the factory, the overvoltage level on each LZS unit is set as given in table 6 on page 5. If a different OVP threshold is required, it can be adjusted using the following method:

1. Turn the OVP Adjust potentiometer fully clockwise (at least 10 turns).
2. With the power supply unloaded, set V_{out} to the OVP threshold desired. In cases where the desired OVP threshold exceeds the unit's adjustment range maximum of 29.4V, a programming resistor (see figures 4 & 5) will temporarily be needed to provide the higher output voltage to perform the adjustment. Once adjusted, remove the programming resistor. Alternatively, you may use an external voltage source to set the OVP threshold as shown in figures 4 & 5.
3. Slowly turn the OVP adjust control counter clockwise while monitoring the output voltage. Stop turning the control immediately when the red FAULT indicator lights, indicating an OVP shutdown. At that point, the OVP threshold is set to the desired value.

4.5 OVERTEMPERATURE AND OVERVOLTAGE SHUTDOWN

LZS-A1000 power supplies will automatically shut down if operating conditions cause excessive internal heating or excessive output voltage. After the occurrence of an overvoltage shut down, input power must be interrupted or the remote on/off feature must be toggled to re-establish the output. Overtemp shutdown resets itself once the unit has cooled off by approximately 10°C.

4.6 AUXILIARY CONTROL AND ALARM SIGNALS

LZSa power supplies provide auxiliary control and alarm signals per page 5. These signals are accessible via the 15-pin, sub miniature "D" connector, located below the output terminals of the unit.

5. Figures

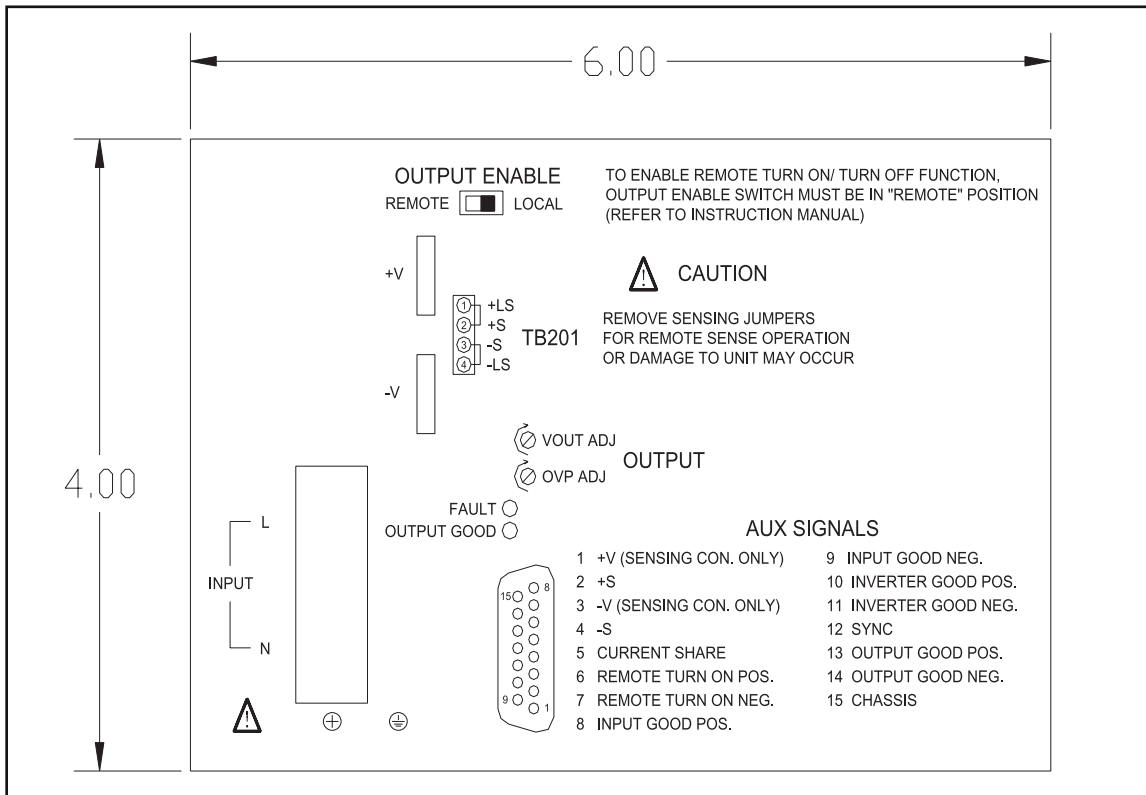

Figure 1 - PIN Assignments for TB201 and chassis mounted "D" connector

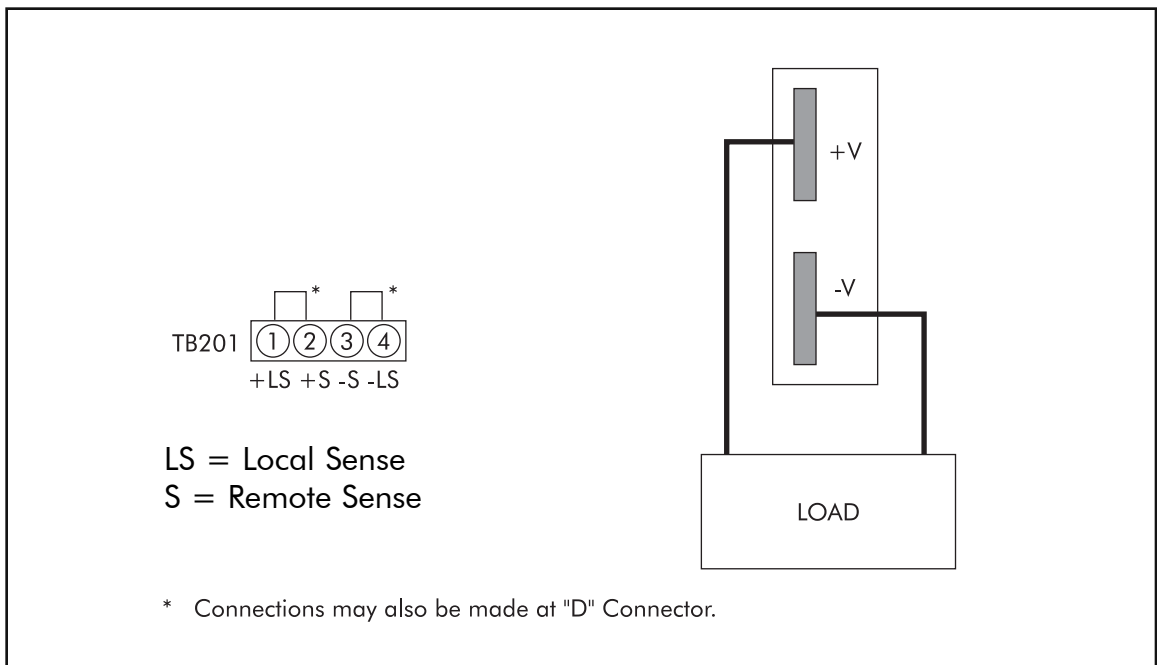

Figure 2 - Typical Local Sense Connection

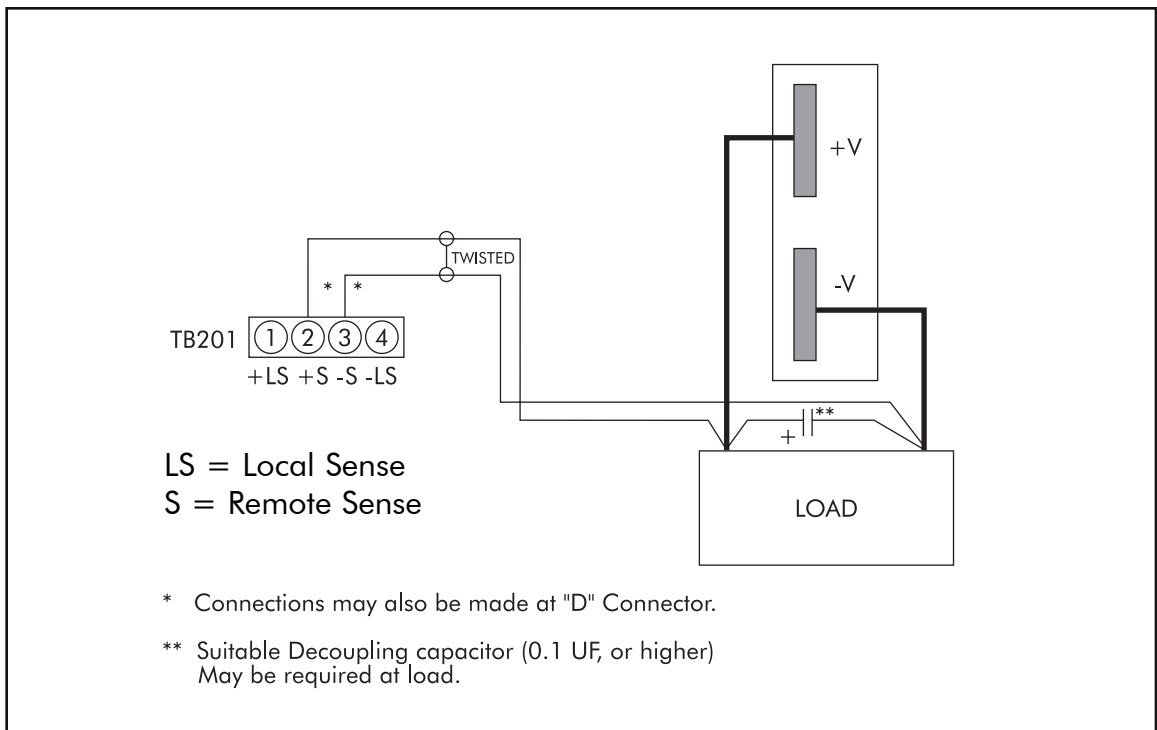

Figure 3 - Typical Remote Sense Connection

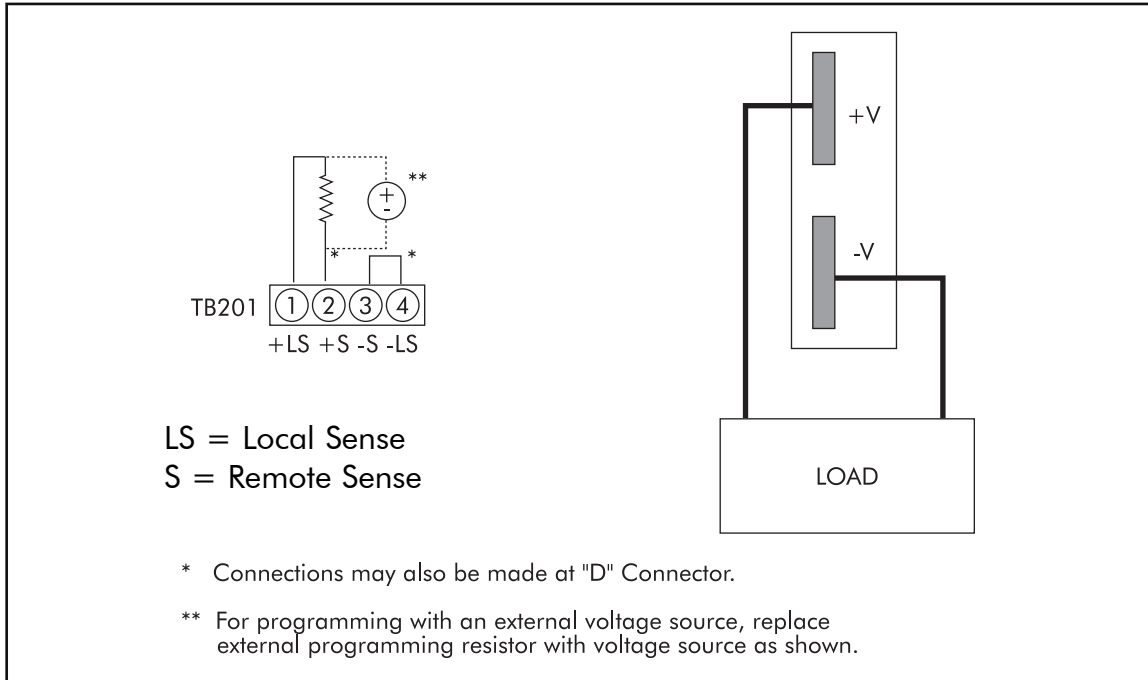

Figure 4 - Remote Voltage Control with an External Programming Resistor or Voltage Source (Local Sensing)

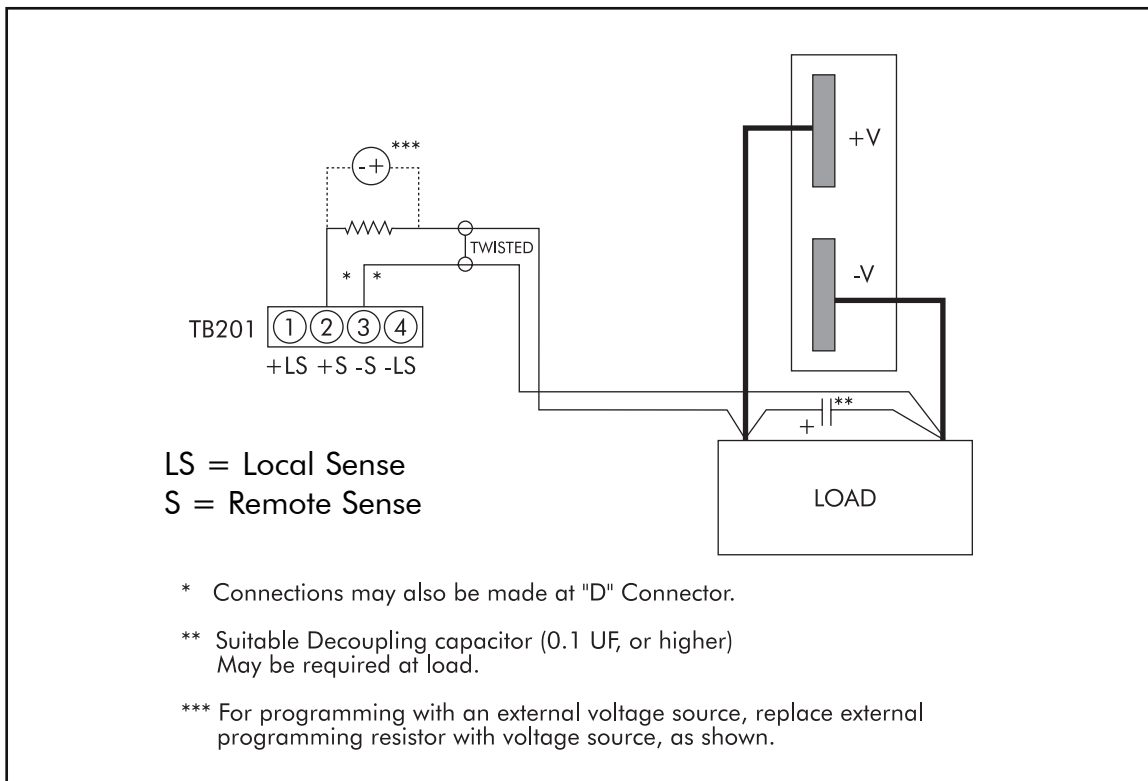

Figure 5 - Remote Voltage Control with an External Programming Resistor or Voltage Source (Remote Sensing)

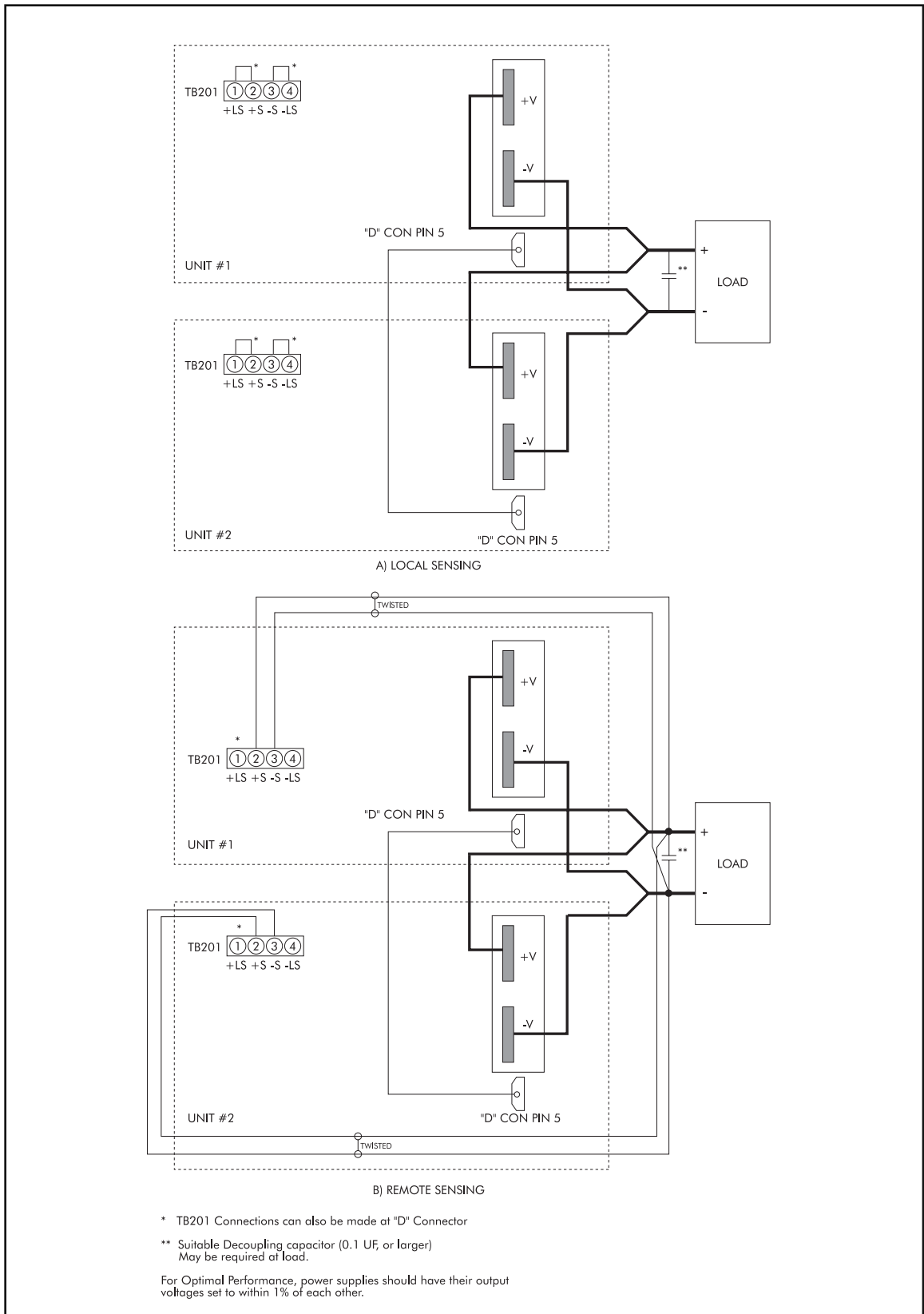

Figure 6 - Parallel Operation

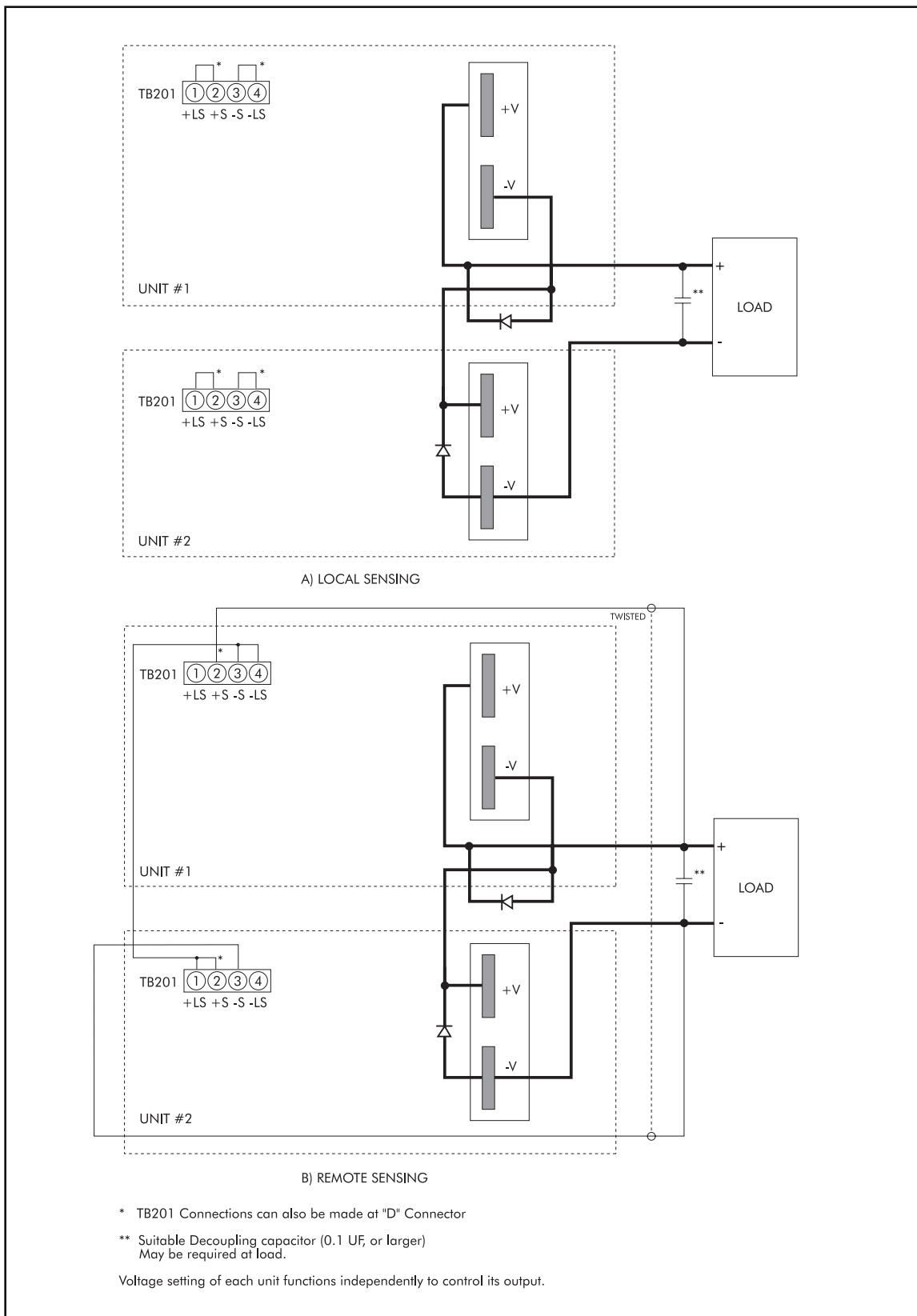

Figure 7 - Series Operation

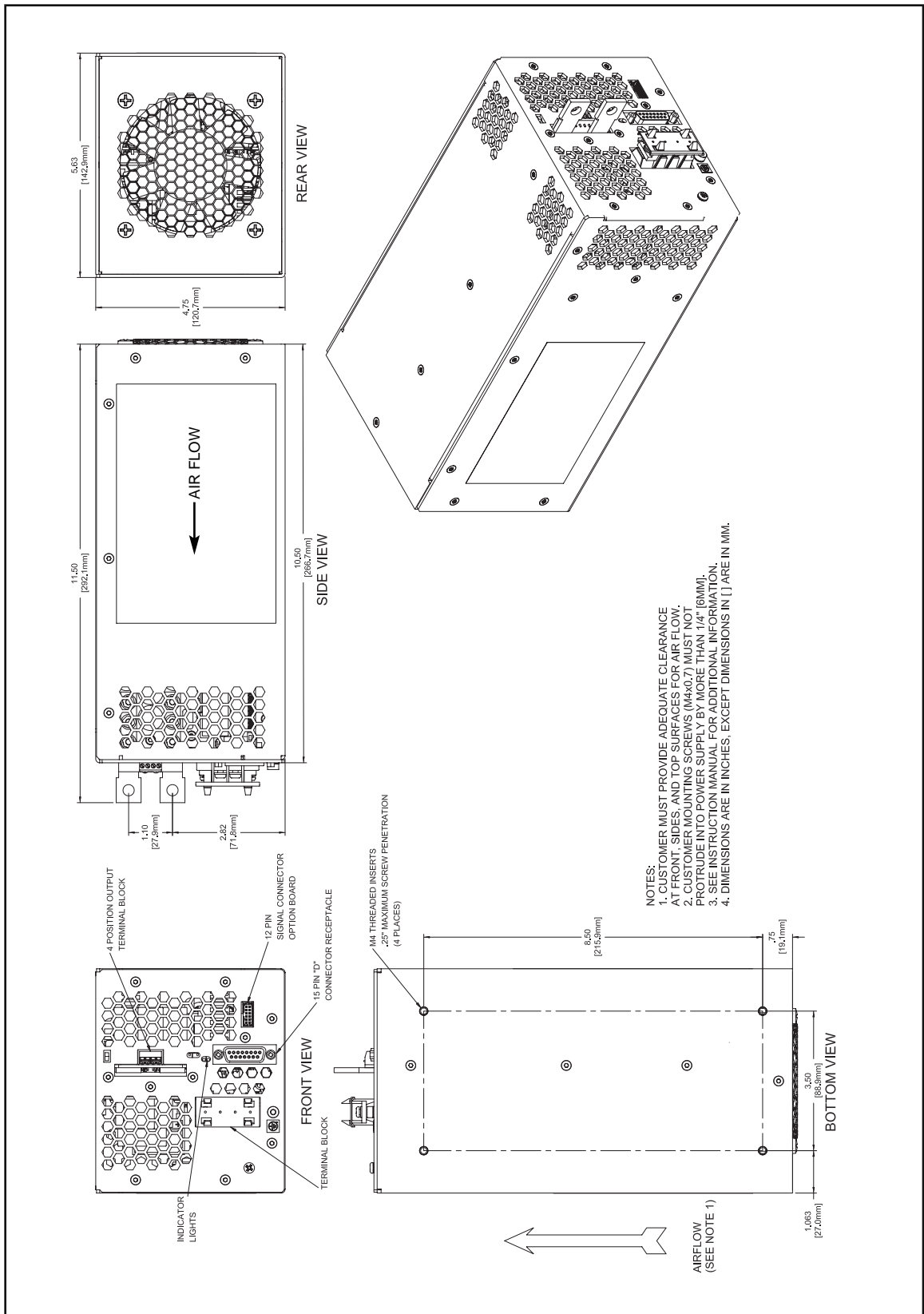

Figure 8 - Outline Drawing