



EL160.80.50

Operation Manual

Table of contents:

1 EL160.80.50 display 3

1.1 Features and benefits 3

2 Installation and handling 3

2.1 Mounting 4

2.2 Cable length 4

2.3 Cleaning 4

2.4 Avoiding burn-in 4

3 Specifications 5

3.1 Control basics 5

3.2 Power 5

3.3 Connectors 6

3.3.1 Standard data and power connector 6

3.3.2 Dimming connector J2 7

3.3.3 Locking power and data connector 7

3.4 Interface information 8

3.4.1 Video input signals 8

3.5 Self-test mode 10

3.6 Optical 10

3.7 Dimming 10

3.8 Environmental 11

3.9 Reliability 12

3.10 Safety and EMI performance 12

3.11 Mechanical characteristics 12

3.12 Component envelope 12

4 Description of warranty 14

5 Ordering information 15

6 Support and service 16

7 RoHS II 16

1 EL160.80.50 display

The EL160.80.50 thin film electroluminescent (TFEL) display is a low cost, high performance alternative to small LCDs, LEDs or VFDs. The EL160.80.50 utilizes Lumineq® Displays' proprietary Integral Contrast Enhancement (ICEBrite™) technology to achieve unparalleled image quality without the use of expensive filters. This small graphics display excels in a wide range of ambient lighting environments while effectively eliminating the blooming common to other high-bright displays.

The display consists of a TFEL glass panel and control electronics assembled into a space-saving, rugged package for easy mounting. The EL160.80.50 is easily interfaced using standard 4-bit LCD control signals. Each of the 12,800 pixels is individually addressable to clearly display high information content graphics and text. The display is equivalent to a 10 x 26 character display in text mode (assuming 5 x 7 characters).

1.1 Features and benefits

- Excellent visual performance:
 - High brightness and contrast
 - Wide viewing angle > 179°
- Rapid display response < 1 ms
- Space efficient mechanical package
- Low EMI emissions
- Extremely rugged and durable
- Reliable, long operating life
- 4-bit LCD-type interface

2 Installation and handling

Do not drop, bend, or flex the display. Do not allow objects to strike the surface of the display.

CAUTION: The display uses CMOS and power MOS-FET devices. These components are electrostatic sensitive. Unpack, assemble, and examine this assembly in a static-controlled area only. When shipping, use packing materials designed for protection of electrostatic-sensitive components.

2.1 Mounting

Properly mounted, TFEL displays can withstand high shock loads as well as severe vibration found in demanding applications. However the glass panel used in a TFEL display will break if subjected to bending stresses, high impact, or excessive loads.

Avoid bending the display. Stresses are often introduced when a display is mounted into a product. Ideally, the mounting tabs of the display should be the only point of contact with the system. Use a spacer or boss for support; failure to do so will bend the display and cause the glass to break. The instrument enclosure or frame should not flex or distort in such a way that during use the bending loads might be transferred to the display. Mounting surfaces should be flat to within ± 0.6 mm (± 0.25 ""). Use all the mounting holes provided; failure to do so will impair the shock and vibration resistance of the final installation.

The EL160.80.50 is a tab mounted display. Use appropriate length standoffs to assure that screws through the mounting tabs do not introduce bending stresses into the display. Do not deflect the circuit board out of its normal plane.

CAUTION: Properly mounted, this display can withstand high shock loads and severe vibration in aggressive environments. However, the glass panel used in this display will break when subjected to bending stresses, high impact, or excessive loads.

To prevent injury in the event of glass breakage, a protective overlay should be used on the viewer side of the display.

WARNING: These products generate voltages capable of causing personal injury (high voltage up to 235 V_{AC}). Do not touch the display electronics during operation.

2.2 Cable length

A maximum cable length of 600 mm (24 in.) is recommended. Longer cables may cause data transfer problems between the data transmitted and the display input connector. Excessive cable lengths can pick up unwanted EMI.

2.3 Cleaning

As with any glass or coated surface, care should be taken to minimize scratching. Clean the display glass with mild, water-based detergents only. Apply the cleaner sparingly to a soft cloth, then wipe the display. Disposable cleaning cloths are recommended to minimize the risk of inadvertently scratching the display with particles embedded in a re-used cloth. Particular care should be taken when cleaning displays with anti-glare and anti-reflective films.

2.4 Avoiding burn-in

As with other light emitting displays, displaying fixed patterns on the screen for extended periods of time can cause burn-in, where luminance variations can be noticed. Use a screensaver or image inversion to avoid causing burn-in on the display.

3 Specifications

Performance characteristics are guaranteed when measured at 25 °C with rated input voltage unless otherwise specified.

3.1 Control basics

The TFEL panel is a matrix structure with column and row electrodes arranged in an X-Y formation. Light is emitted when an AC voltage of sufficient amplitude is applied at a row-column intersection. The display operation is based on the symmetric, line-at-a-time data addressing scheme.

3.2 Power

The supply voltages are shown in Table 1. All internal high voltages are generated from the display supply voltage (V_H). The logic supply voltage (V_L) should be present whenever video input signals or V_H is applied. The minimum and maximum specifications in this manual should be met, without exception, to ensure the long-term reliability of the display. Beneq does not recommend operation of the display outside these specifications.

Table 1. DC input voltage requirements

Parameter	Symbol	Min	Typ.	Max	Absolute Max
Logic supply voltage	V_L	4.75 V	5 V	5.25 V	6 V
Logic supply current at +5 V	I_L			40 mA _{DC}	
Display supply voltage	V_H	10 V	12 V	15 V	15 V
Supply current at +12 V	I_H		0.5 A	0.80 A _{DC}	
Power consumption 5 V/12 V					
@ 60 Hz Frame Rate			2.0 W	2.9 W	
@ 120 Hz Frame Rate			2.7 W	4.2 W	
@ 240 Hz Frame Rate			4.4 W	7.0 W	

CAUTION: Absolute maximum ratings are those values beyond which damage to the device may occur.

Table 2. Video input requirements

Description	Minimum	Maximum	Units	Notes
Absolute input voltage range	-0.3	5.5	V	$V_L = 5.0\text{ V}$
Video logic high voltage	70%	100%	V_L	All input thresholds are CMOS
Video logic low voltage	0	20%	V_L	
Video logic input current	-10	+10	μA	
Input capacitance	-	15	pF	

There is no overcurrent protection on either the V_H or V_L inputs to protect against catastrophic faults. Beneq recommends the use of a series fuse on the 12-volt supply (V_H). A general guideline is to rate the fuse at 1.8 to 2 times the display maximum current rating.

3.3 Connectors

3.3.1 Standard data and power connector

The 160.80.50 displays use the Samtec STMM-110-01-T-D or equivalent connector. The mating connector is in the Samtec TCSD family of cable strips. The proper connector, user-specified cable length, and connector configuration are supplied as a single unit. Consult your Samtec representative for the cable/connector options.

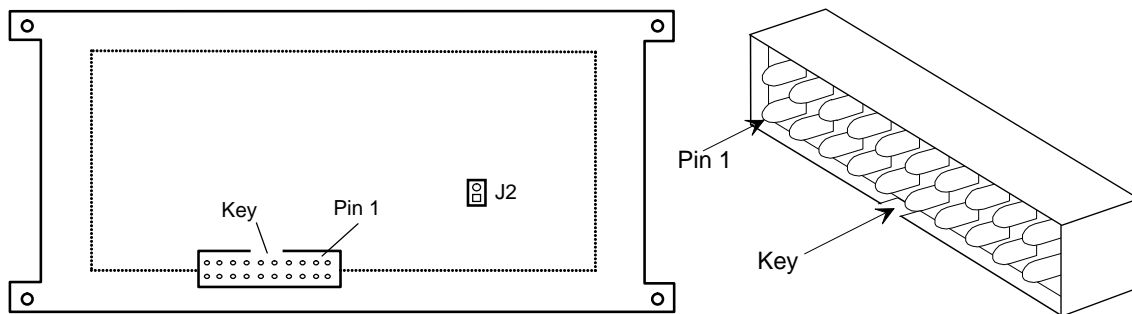

Figure 1. Data/power connector

Table 3. Connector J2 pin assignments

Pin	Signal	Description	Pin	Signal	Description
1	V _H	+12 V Power	2	V _H	+12 V Power
3	Self-test	Self-test Input ¹	4	GND	Ground
5	V _L	+5 V Power	6	GND	Ground
7	VS	Vertical Sync	8	GND	Ground
9	HS	Horizontal Sync	10	GND	Ground
11	VCLK	Video Clock	12	GND	Ground
13	VID ₀	Video Data	14	GND	Ground
15	VID ₁	Video Data	16	GND	Ground
17	VID ₂	Video Data	18	GND	Ground
19	VID ₃	Video Data	20	GND	Ground

¹ Connect pin 3 to ground for normal display operation.

3.3.2 Dimming connector J2

The dimming connector is a Leoco part number 2011P02V000, which is a 2-pin, 2 mm, header. The recommended mate is a Leoco part number 2010S020000 (housing) with Leoco part number 2033TPB0000 (contact).

For a discussion of the dimming feature, refer to the Dimming section below, under Optical Performance.

3.3.3 Locking power and data connector

An optional locking connector, Samtec part number EHT-110-01-T-D is available on the Industrial (IN) and Extended Temperature (ET) versions of the 160.80.50 display. The mating connector is the Samtec TCSD family of cable strips. Compatibility with non-Samtec equivalents should be verified before use.

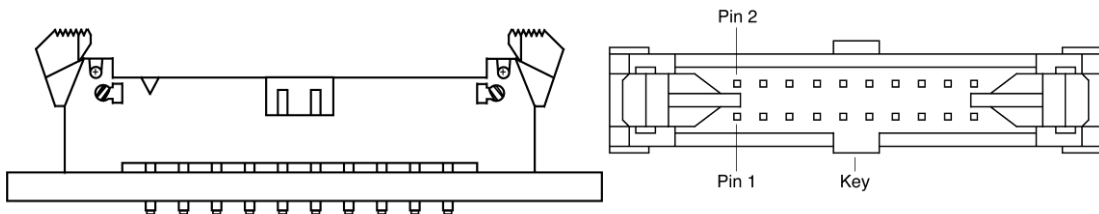

3.4 Interface information

Beneq TFEL Small Graphics Displays (SGD) incorporate an interface that is similar to many LCD interfaces. This interface is supported by a variety of off-the-shelf chip sets which take care of all display control functionality, freeing the system processor for other tasks. Designers select the chip set that best suits their particular architecture and price point. This 4-bit LCD-type video interface provides a low cost, flexible method for controlling display brightness and power consumption.

3.4.1 Video input signals

The end of the top line of a frame is marked by VS, vertical sync signal as shown in Figure 3. Video input timing diagram on page 8. The end of each row of data is marked by HS.

The VS signal is active high. It may be independently set to a CMOS low level at any time for longer than one frame period. During the time of VS inactivity the display is blank. Halting VS results in a standby condition to minimize power usage.

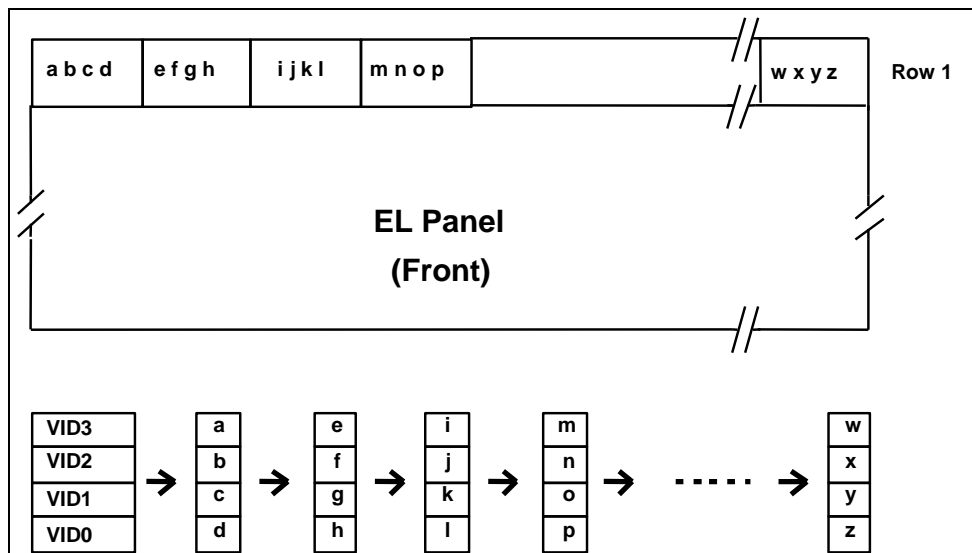

Figure 2. Pixel location versus sequence of data

Timing is compatible with LCD graphics controllers such as the Epson S1D13700 or RAiO RA8835.

Table 4. Video input descriptions

Num	Description	Symbol	Min.	Typ.	Max.	Units
1	HS high time	tHSh	100			ns
2	HS low time	tHSI	40			tVCLK
3	HS to VCLK rising edge	tHSsu	95			ns
4	VID setup to VCLK	tVIDsu	50			ns
5	VID hold from VCLK	tVIDhd	50			ns
6	Video clock period	tVCLK	140			ns
	VCLK rise, fall time	tVCLKrf		10	15	ns
7	VCLK low width	tVCLKl	30			ns
8	VCLK high width	tVCLKh	30			ns
9	VS high setup to HS low	tVShsu	140			ns
10	VS hold after HS	tVShd	140			ns
11	VS low setup to HS high	tVSlsu	140			ns
12	HS period	tHS	51			µs
	VS period	tVS	80			tHS
	Frame rate	fVS	0		240	Hz

Input signals VID₀ through VID₃ contain the video data for the screen. Pixel information is supplied from left to right and from top to bottom four pixels at a time. Video data for one row is latched on the fall of HS.

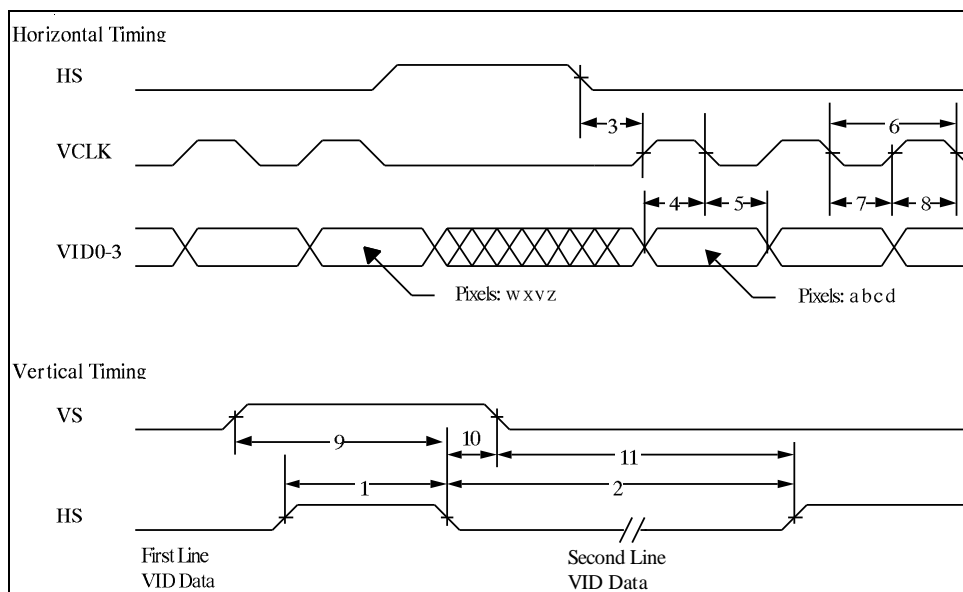

Figure 3. Video input timing diagram

3.5 Self-test mode

The display incorporates a self-test mode composed of three patterns displayed during 5 minutes, and then repeated. The patterns are as follows: Full On, 1 X 1 Checkerboard and the same Checkerboard inverted. The self-test mode is entered by leaving pin 3 unconnected or pulled high.

NOTE: Pin 3 must be connected to Ground for normal display operation.

3.6 Optical

Table 5. Optical characteristics

Luminance		
L _{on} (areal), typ	107 cd/m ²	screen center, 240 Hz frame rate
L _{on} (areal), min	79 cd/m ²	screen center, 240 Hz frame rate
L _{off} (areal), max	0.3 cd/m ²	3 points: center plus two ends measured 0.75 ± 0.25" from adjacent display edges, @ 240 Hz
Non-uniformity		
All pixels fully lit	35%	Maximum difference two of five points, using the formula: LNU%=[1- (min_lum/max_lum)] x 100%
Luminance variation (Temperature)		
Maximum	±20%	Across operating temperature range
Luminance variation (Time)		
Maximum	<20%	10,000 hours at 25 °C ambient
Viewing angle		
Minimum	160°	
Contrast ratio		
Typical	50:1	@ 500 lux ambient, 240 Hz frame rate

3.7 Dimming

There are two standard methods for dimming the EL160.80.50 display. Frame rate dimming allows the brightness of the display to be lowered proportionally by reducing the frame rate. Frame rate dimming is performed within the application by lowering the frame rate of the video input signals. Because brightness is proportional to frame rate, the display can be dimmed by adding pauses between every horizontal period.

The lowest useable frame rate (brightness) is dependent on the perceived flicker of the displayed image, but will most likely be around 60 Hz.

Dimming control circuitry is available on some models of this display. This feature allows manual analog dimming of the brightness from 100% to approximately 5% of the full brightness.

For models which feature analog dimming, connect a 100 k Ω logarithmic external potentiometer to the dimming port. Alternatively, an external voltage or current mode D/A converter may be used to facilitate dimming by sinking a maximum of 250 μ A (for maximum dimming) from pin 1 to pin 2 of the dimming connector.

Analog dimming is a standard feature on the EL160.80.50 IN and EL160.80.50 ET displays.

For more information on frame rate dimming, please refer to Beneq Application Note #120.

3.8 Environmental

Table 6. Environmental characteristics

	Operating	Non-operating
Temperature		
Standard	0 °C to +55 °C	-40 °C to +85 °C
Industrial	-25 °C to +65 °C	-40 °C to +85 °C
Extended	-50 °C to +70 °C	-60 °C to +105 °C
Humidity		
Non-condensing	93% RH max @40 °C, per IEC 60068-2-3	
Condensing		95% RH max from +25 to +55 °C, per IEC 60068-2-30
Altitude		
Operating/non-operating	0 to 18 km (58k ft.), per IEC 60068-2-13	
Vibration		
Random Operating/non-operating	0.10 g ² /Hz, ASD level, 5-500 Hz per IEC 60068-2-64, test Fh.	
Shock		
Operating/non-operating	100 g, 4 ms, half sine wave, per IEC 60068-2-27, test Ea.	

3.9 Reliability

The display MTBF is to be greater than 50,000 hours at 240 Hz with a 90% confidence level at 25 °C.

3.10 Safety and EMI performance

The display will not inhibit the end product from obtaining these certifications: CISPR 22 level B, IEC 801-2, IEC 801-3, EN55022 B, FCC 15 J, or UL1950.

3.11 Mechanical characteristics

Table 7. Mechanical characteristics

Display external dimensions		
millimeters (inches)	width	108.9 (4.29)
	height	57.2 (2.25)
without locking connector	depth	15.8 (0.62)
with locking connector		19.0 (0.75)
Weight (typical)		68 g, typical
Fill factor		64.0% nominal
Display active area		
millimeters (inches)	width	79.9 (3.15)
	height	39.9 (1.57)
Pixel size		
	width	0.50 (.0197)
	height	0.50 (.0197)

3.12 Component envelope

The component envelope shown in Figure 4 illustrates the distance components extend behind the display. Tall components do not necessarily fill this area. Beneq reserves the right to relocate components within the constraints of the component envelope without prior customer notification. For this reason, Beneq advises users to design enclosure components to be outside the component envelope.

Device designers will need to consider their specific system requirements to determine the spacing necessary to maintain the specified ambient temperature. Air flow and surrounding component materials will affect the depth of the air gap.

4 Description of warranty

Seller warrants that the Goods will conform to published specifications and be free from defects in material during warranty time from delivery. To the extent that goods incorporate third-party-owned software, seller shall pass on seller's licensor's warranty to buyer subject to the terms and conditions of seller's license.

Warranty repairs shall be warranted for the remainder of the original warranty period. Buyer shall report defect claims in writing to seller immediately upon discovery, and in any event, within the warranty period. Buyer must return goods to seller within 30 days of seller's receipt of a warranty claim notice and only after receiving seller's return goods authorization. Seller shall, at its sole option, repair or replace the goods.

If goods were repaired, altered or modified by persons other than seller, this warranty is void. Conditions resulting from normal wear and tear and buyer's failure to properly store, install, operate, handle or maintain the goods are not within this warranty. Repair or replacement of goods is seller's sole obligation and buyer's exclusive remedy for all claims of defects. If that remedy is adjudicated insufficient, Seller shall refund buyer's paid price for the goods and have no other liability to buyer.

All warranty repairs must be performed at seller's authorized service center using parts approved by seller. Buyer shall pay costs of sending goods to seller on a warranty claim and seller shall pay costs of returning goods to buyer. The turnaround time on repairs will usually be 30 working days or less. Seller accepts no added liability for additional days for repair or replacement.

If seller offers technical support relating to the goods, such support shall neither modify the warranty nor create an obligation of seller. Buyer is not relying on seller's skill or judgment to select goods for buyer's purposes. Seller's software, if included with goods, is sold as is, and this warranty is inapplicable to such software.

SELLER DISCLAIMS ALL OTHER WARRANTIES, EXPRESS OR IMPLIED, INCLUDING BUT NOT LIMITED TO, IMPLIED WARRANTIES OF MERCHANTABILITY AND FITNESS FOR A PARTICULAR PURPOSE.

5 Ordering information

Product	Part number	Description
EL160.80.50 Standard Product	996-0267-15LF	0 to +55 °C temperature range
EL160.80.50-IN Industrial Product	996-0267-20LF	Industrial operating temperature range from -25 to +65 °C. Analog dimming circuitry is standard.
EL160.80.50-ET Extended Temperature	996-0267-18LF	Extended temperature range from -50 to +70 °C. Analog dimming and the locking connector are standard features.
EL160.80.50-ET CC	996-0267-17LF	EL160.80.50-ET with conformal coating.

Design and specifications are subject to change without notice.

Beneq continues to provide optional, and in many cases custom, features to address the specific customer requirements. Consult Beneq Sales for pricing, lead time and minimum quantity requirements.

6 Support and service

Beneq Oy is a Finnish company based in Espoo, Finland, with a world-wide sales distribution network. Full application engineering support and service are available to make the integration of Lumineq displays as simple and quick as possible for our customers.

RMA Procedure: For a Returned Material Authorization number, please contact Beneq Oy by email (rma.lumineq@beneq.com) with the model number(s), serial number(s) and brief description of the problem. When returning goods for repair, please include a brief description of the problem, and mark the outside of the shipping container with the RMA number.

7 RoHS II

Beneq Oy is committed to continuous improvement. As part of this process we are fully in support of EU directive 2011/65/EU, the Restriction of Hazardous Substances, commonly known as RoHS II or RoHS Recast, which, compared to RoHS, keeps the restrictions on the original six hazardous substances, including lead (Pb) in electronic equipment. It also expands these restrictions to previously exempted categories including medical devices and monitoring and control instruments.

Beneq part number with an "LF" suffix designation indicates RoHS compliance, as shown on the part number label affixed to the display and on the box containing the display.

This document is compiled and kept up-to-date as conscientiously as possible. Beneq cannot, however, guarantee that the data are free of errors, accurate or complete and, therefore, assumes no liability for loss or damage of any kind incurred directly or indirectly through the use of this document. The information in this document is subject to change without notice. All texts, pictures, graphics and any other contents of this document and their layout are protected by copyright and other protective laws. The aforementioned contents may not be duplicated, modified or used in other electronic or printed publications without the prior consent of Beneq. Unless otherwise stated, all trademarks are protected under trademark laws, especially the Beneq trademarks, logos, emblems and nameplates. The patents and trademarks presented in this document are the intellectual property of Beneq Oy. Beneq and Lumineq are registered trademarks of Beneq Oy. ICEBrite is a trademark of Beneq Oy.