

harbus[®] HM with 6 rows, 2.00 mm pitch

Page

harbus[®] HM 6-row – general information	02.02
Technical characteristics	02.03
Straight male connectors with press-in termination	02.04
Angled female connectors with press-in termination	02.08
Angled female connectors with solder (SMC) termination	02.10
Compatibility with OBSAI	02.12

General information

In comparison to the standard 5-row *har-bus*[®] HM series, this new 6-row version offers a significantly higher contact density, thus permitting applications where very high contact density is important. Typically, for a signal transmission of 1.5 Gbps it is possible to obtain 7.5 differential pairs per cm of card edge (see figure 1). For a signal transmission of 2.5 Gbps at least 5 differential pairs per cm of card edge can be obtained (see figure 2).

Male and female connectors are both available with 72 or 144 contacts and can be supplied in reel or tube packaging.

A	+	-	G	G	+	-	G	G	+	-	G	G	+	-	G	G	+	-	G	G	+	-	G	G	+	-
B	G	G	+	-	G	G	+	-	G	G	+	-	G	G	+	-	G	G	+	-	G	G	+	-	G	G
C	+	-	G	G	+	-	G	G	+	-	G	G	+	-	G	G	+	-	G	G	+	-	G	G	+	-
D	G	G	+	-	G	G	+	-	G	G	+	-	G	G	+	-	G	G	+	-	G	G	+	-	G	G
E	+	-	G	G	+	-	G	G	+	-	G	G	+	-	G	G	+	-	G	G	+	-	G	G	+	-
F	G	G	+	-	G	G	+	-	G	G	+	-	G	G	+	-	G	G	+	-	G	G	+	-	G	G

Figure 1

A	+	-	G	+	-	G	+	-	G	+	-	G	+	-	G	+	-	G	+	-	G	+	-	G	+	-
B	G	G	G	G	G	G	G	G	G	G	G	G	G	G	G	G	G	G	G	G	G	G	G	G	G	G
C	+	-	G	+	-	G	+	-	G	+	-	G	+	-	G	+	-	G	+	-	G	+	-	G	+	-
D	G	G	G	G	G	G	G	G	G	G	G	G	G	G	G	G	G	G	G	G	G	G	G	G	G	G
E	+	-	G	+	-	G	+	-	G	+	-	G	+	-	G	+	-	G	+	-	G	+	-	G	+	-
F	G	G	G	G	G	G	G	G	G	G	G	G	G	G	G	G	G	G	G	G	G	G	G	G	G	G

Figure 2

Male connectors

Each contact position can be loaded with any of the 12 different contacts lengths shown (see figure 3).

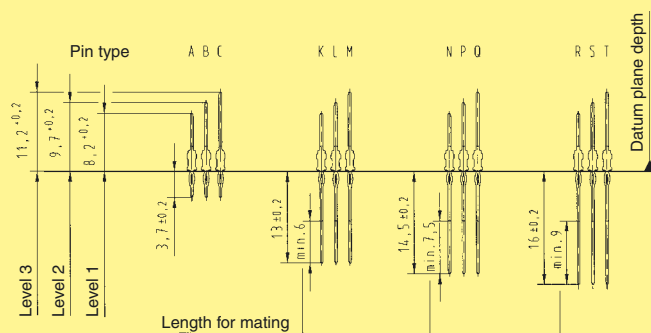
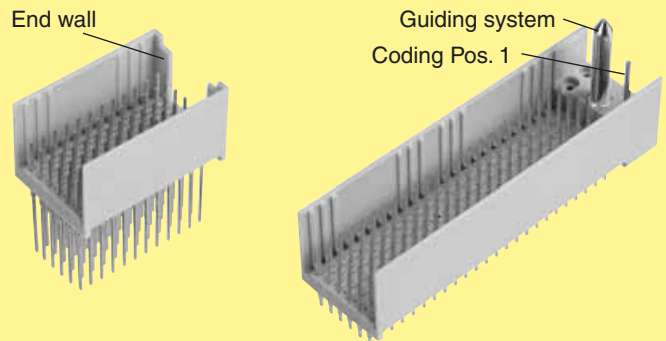

Figure 3

All male connectors can be supplied with end wall, coding pins and guiding system.



Female connectors with press-in termination

The 6-row female connector needs comparable space on the daughter card as the 5-row versions, as it has similar outer dimensions. Compared to the male connectors, coding pins and a guiding system are available upon request too.

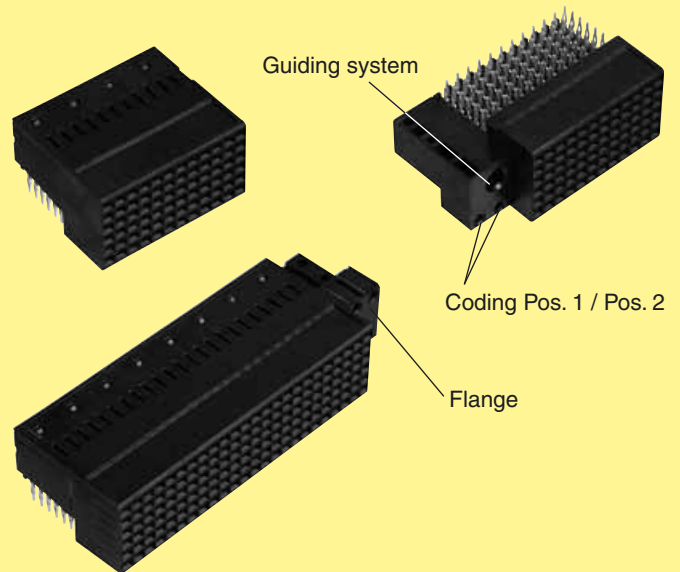

Female connectors in SMC (Surface Mount Compatible) technology

Using the reflow soldering process, these 6-row female connectors in SMC technology can be soldered to the PCB at the same time as other SMC components. So the handling cost can be reduced significantly and there is no need for a separate press-in process. These connectors are made from a high temperature plastic material that can withstand up to 260°C (lead free soldering). To hold the connector securely on the PCB before the solder process, kinked contacts are offered as standard on both connector sides. Further SMC information see chapter 01.

harbus[®] HM 6-row

Design	: complementary to IEC 61 076-4-101 (2 mm hard metric specification)																
Number of contacts	: 72 or 144																
Contact spacing	: 2.00 mm (1.50 mm between contact rows on the termination side of female connectors)																
Working current	: 1.0 A (24 °C temp. raise) 1.5 A (52 °C temp. raise) 2.0 A (88 °C temp. raise)																
Test voltage $U_{r.m.s.}$: min. 750 V																
Contact resistance	: < 20 mΩ																
Impedance (differential)	: 100 Ω																
Typical differential data rate	: 1.5 - 2.5 Gbps																
Temperature range during reflow soldering	: - 55 °C ... + 125 °C max. 260 °C (peak temperature)																
Performance level*	: performance level 2 = 250 mating cycles performance level 1 = 500 mating cycles																
Termination technique	: press-in for male and female connectors SMC for female connectors, compatible with lead-free solder process																
Pcb characteristics	: min. 1.4 mm for male and female connectors with press-in terminations 1.6 mm - 2.4 mm for female connectors with SMC terminations																
Recommended configuration of plated through holes	<table border="1"> <thead> <tr> <th></th> <th>press-in</th> <th>SMC</th> </tr> </thead> <tbody> <tr> <td>Plated hole-Ø</td> <td>0.6 ± 0.05 mm</td> <td>0.7 ^{+0.07}/_{-0.05} mm</td> </tr> <tr> <td>Hole-Ø</td> <td>0.7 ± 0.02 mm</td> <td>0.8 ± 0.02 mm</td> </tr> <tr> <td>Cu</td> <td>30 - 50 µm</td> <td>30 - 50 µm</td> </tr> <tr> <td>Sn</td> <td>5 - 15 µm</td> <td>5 - 15 µm</td> </tr> </tbody> </table>			press-in	SMC	Plated hole-Ø	0.6 ± 0.05 mm	0.7 ^{+0.07} / _{-0.05} mm	Hole-Ø	0.7 ± 0.02 mm	0.8 ± 0.02 mm	Cu	30 - 50 µm	30 - 50 µm	Sn	5 - 15 µm	5 - 15 µm
	press-in	SMC															
Plated hole-Ø	0.6 ± 0.05 mm	0.7 ^{+0.07} / _{-0.05} mm															
Hole-Ø	0.7 ± 0.02 mm	0.8 ± 0.02 mm															
Cu	30 - 50 µm	30 - 50 µm															
Sn	5 - 15 µm	5 - 15 µm															
Mating force	: < 0.75 N/pin																
Materials																	
Mouldings	: Thermoplastic resin, glass-fibre filled, UL 94-V0																
Contacts	: Copper alloy																
Contact surface	: Au/Ni																

Packaging	
Tube	: Male connectors and female connectors with press-in terminations
Tape & Reel	: Female connectors with SMC terminations

* Other platings on request

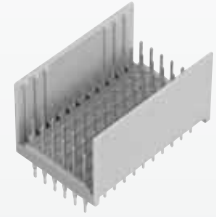

Male connectors straight, with press-in termination

Identification	Number of contacts	Contact length [mm] mating side	Contact length [mm] termination side	Part number	Contact configuration
Connectors without flange without coding without endwall	72	8.2	3.7	17 41 072 1204	
				17 41 072 2204	
	144	8.2	3.7	17 44 144 1205	
				17 44 144 2205	
Connectors without flange without coding <u>with</u> endwall	72	8.2	3.7	17 42 072 1203	
				17 42 072 2203	
	144	8.2	3.7	17 45 144 1204	
				17 45 144 2204	

harbus[®] HM 6-row

Connector dimensions see pages 02.06 and 02.07.
The pin types A, B, C ... R, S, T can be mixed in any configuration.
Please request the part number.

Thin print part numbers: performance level 1
Bold print part numbers: performance level 2

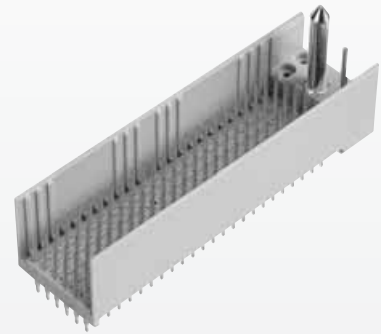

Male connectors straight, with press-in termination

Identification	Number of contacts	Contact length [mm] mating side	termination side	Part number	Contact configuration
Connectors with flange without coding without endwall	72	8.2	3.7	17 43 072 1209 17 43 072 2209	
	144	8.2	3.7	17 46 144 1207 17 46 144 2207	
Connectors with flange with coding 1 without endwall	72	8.2	3.7	17 43 072 1211 17 43 072 2211	
	144	8.2	3.7	17 46 144 1209 17 46 144 2209	
Connectors with flange with coding 2 without endwall	72	8.2	3.7	17 43 072 1210 17 43 072 2210	
	144	8.2	3.7	17 46 144 1208 17 46 144 2208	
Connectors with flange with coding 3 (= coding 1 + 2) without endwall	72	8.2	3.7	17 43 072 1212 17 43 072 2212	
	144	8.2	3.7	17 46 144 1210 17 46 144 2210	

Connector dimensions see pages 02.06 and 02.07.
The pin types A, B, C ... R, S, T can be mixed in any configuration.
Please request the part number.

Thin print part numbers: performance level 1
Bold print part numbers: performance level 2

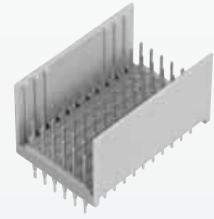

Male connectors straight, with press-in termination

Drawing

Dimensions in mm

Connector dimensions [mm]

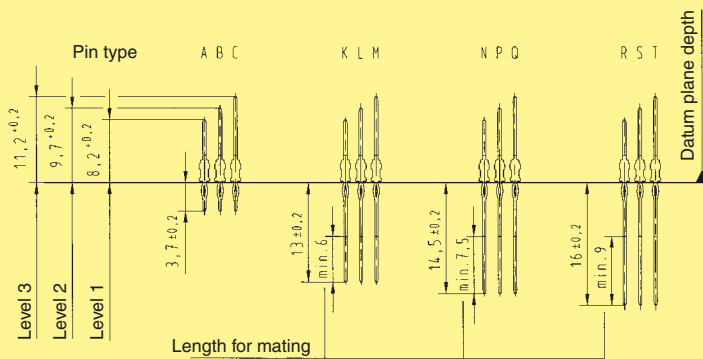

Contact positions	x ₁	x ₂	x ₃
72	23.9	11 x 2 (= 22)	24.9
144	47.9	23 x 2 (= 46)	48.9

without flange
without coding
without endwall

without flange
without coding
with endwall

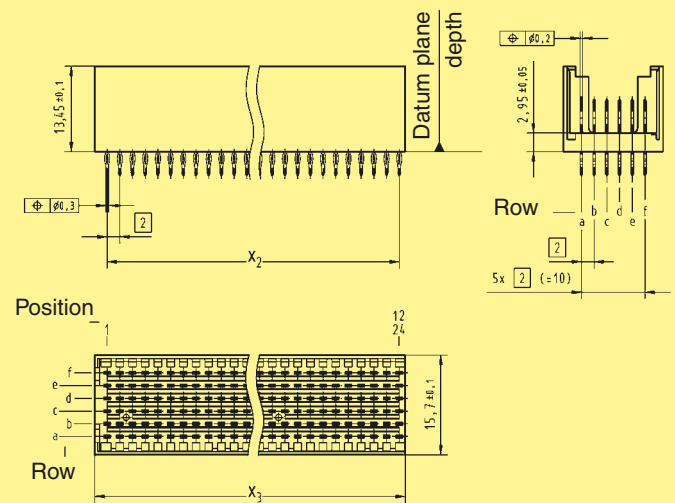
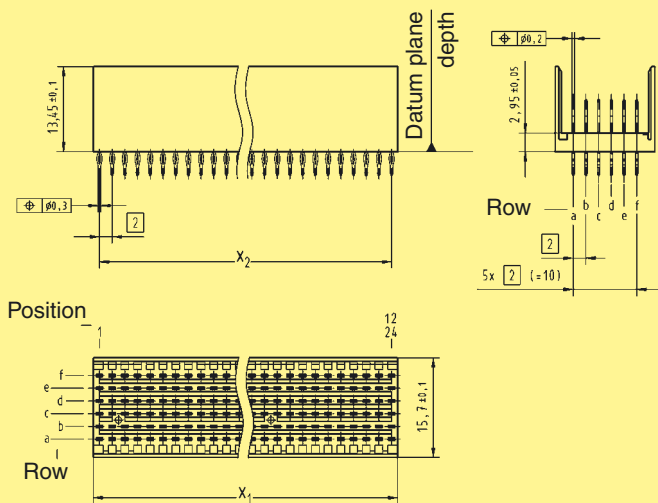

Board drillings

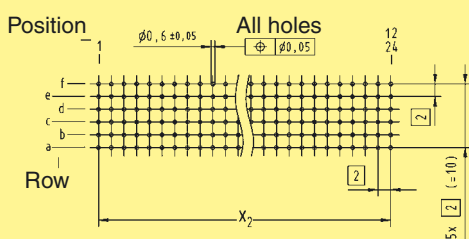

Board drillings

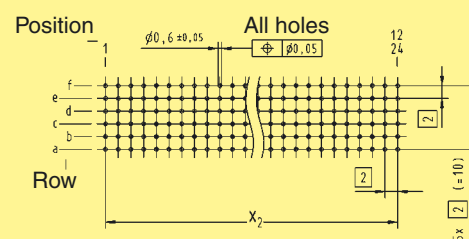

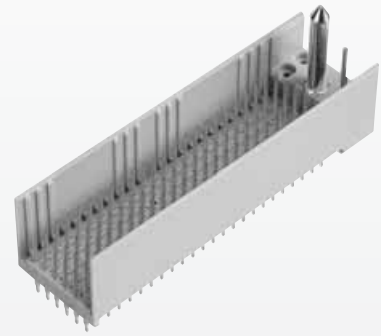

Male connectors straight, with press-in termination

Drawing

Dimensions in mm

Connector dimensions [mm]

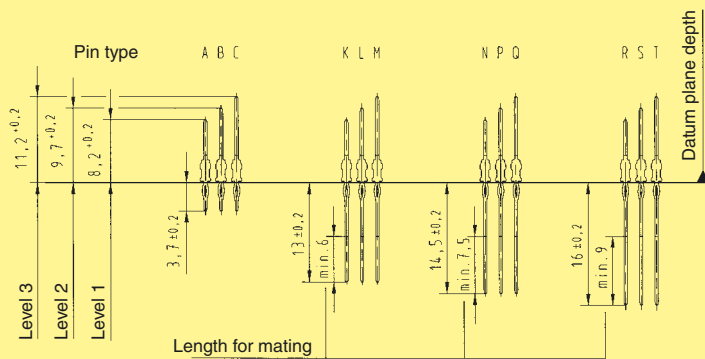

Contact positions	X ₂	X ₄
72	11 x 2 (= 22)	30.9
144	23 x 2 (= 46)	54.9

with flange
with coding
without endwall

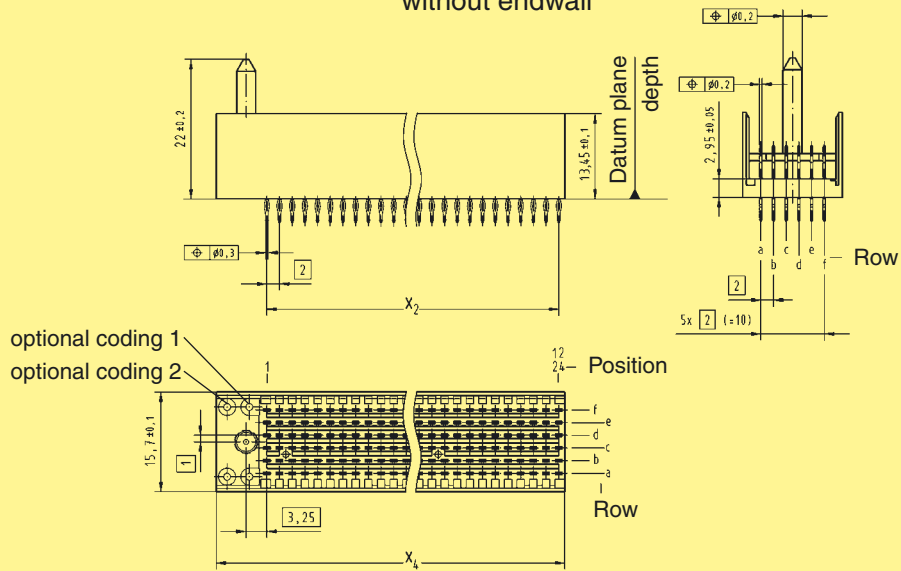

Board drillings

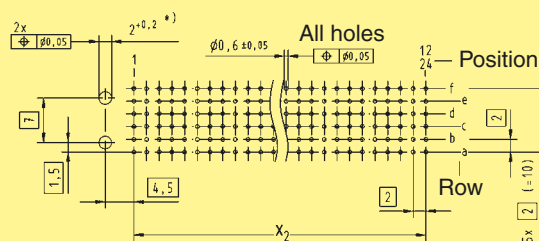

* Non-metallized drillings

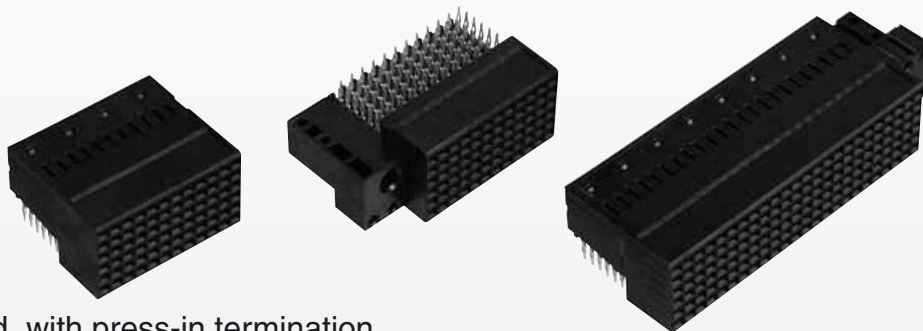

Female connectors angled, with press-in termination

harbus[®] HM 6-row

Identification	Number of contacts	Contact length [mm] termination side	Part number
Connectors without flange without coding	72	3.35	17 51 072 1102 17 51 072 2102
	144	3.35	17 54 144 1102 17 54 144 2102
Connectors <u>with</u> flange without coding	72	3.35	17 52 072 1105 17 52 072 2105
	144	3.35	17 55 144 1105 17 55 144 2105
Connectors <u>with</u> flange <u>with</u> coding 1	72	3.35	17 52 072 1106 17 52 072 2106
	144	3.35	17 55 144 1106 17 55 144 2106
Connectors <u>with</u> flange <u>with</u> coding 2	72	3.35	17 52 072 1107 17 52 072 2107
	144	3.35	17 55 144 1107 17 55 144 2107
Connectors <u>with</u> flange <u>with</u> coding 3 (= coding 1 + 2)	72	3.35	17 52 072 1108 17 52 072 2108
	144	3.35	17 55 144 1108 17 55 144 2108

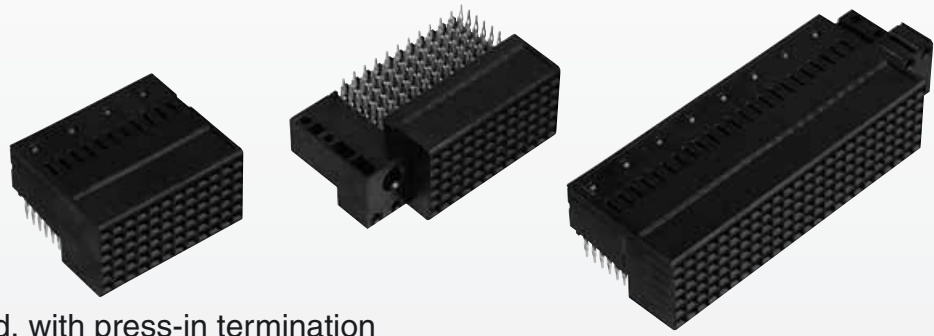

Female connectors angled, with press-in termination

Drawing

Dimensions in mm

Connector dimensions [mm]

without flange
without coding

with flange
with coding

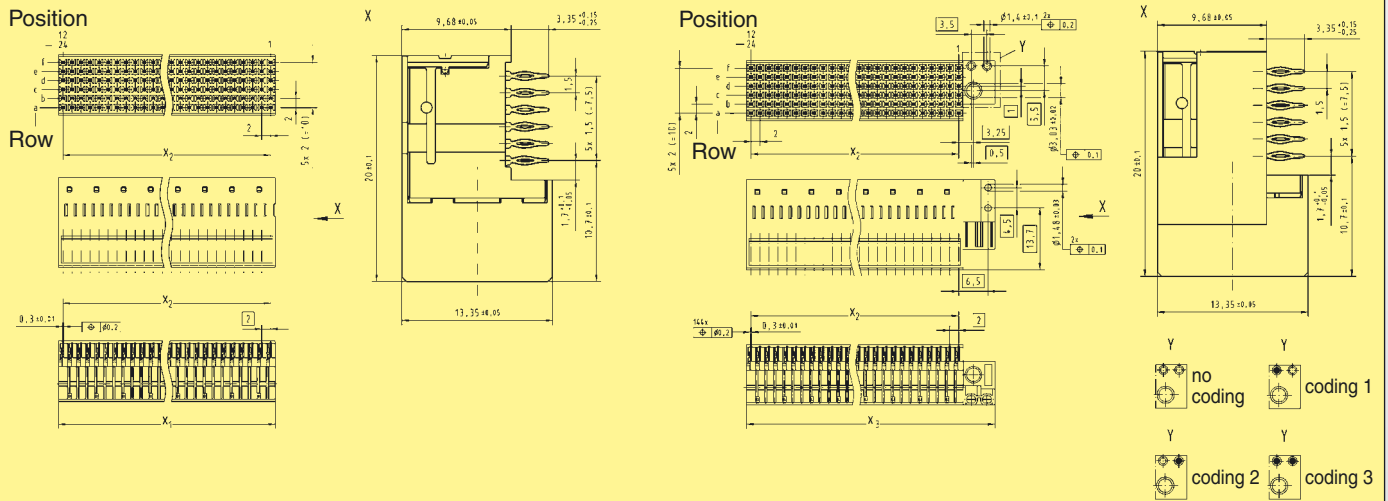

Contact positions	X ₁	X ₂	X ₃
72	24.0	11 x 2 (= 22)	31.0
144	48.0	23 x 2 (= 46)	55.0

Board drillings

Board drillings

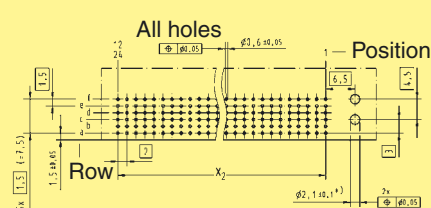
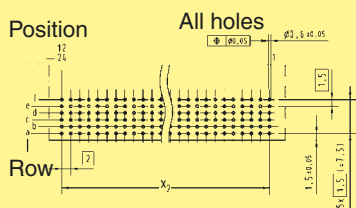

* Non-metallized drillings

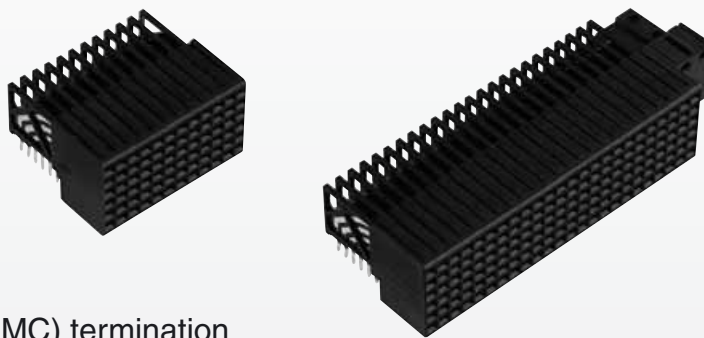

Female connectors angled, with solder (SMC) termination

harbus[®] HM 6-row

Identification	Number of contacts	Contact length [mm] termination side	Part number
Connectors without flange without coding	72	2.5	17 51 072 1802 17 51 072 2802
	144	2.5	17 54 144 1802 17 54 144 2802
Connectors <u>with</u> flange without coding	72	2.5	17 52 072 1805 17 52 072 2805
	144	2.5	17 55 144 1805 17 55 144 2805
Connectors <u>with</u> flange <u>with</u> coding 1	72	2.5	17 52 072 1806 17 52 072 2806
	144	2.5	17 55 144 1806 17 55 144 2806
Connectors <u>with</u> flange <u>with</u> coding 2	72	2.5	17 52 072 1807 17 52 072 2807
	144	2.5	17 55 144 1807 17 55 144 2807
Connectors <u>with</u> flange <u>with</u> coding 3 (= coding 1 + 2)	72	2.5	17 52 072 1808 17 52 072 2808
	144	2.5	17 55 144 1808 17 55 144 2808

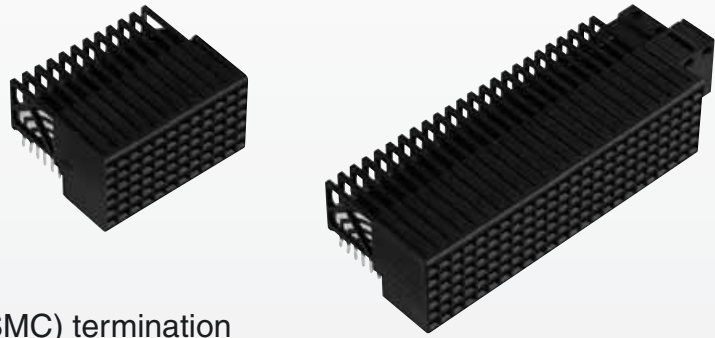

Female connectors angled, with solder (SMC) termination

Drawing

Dimensions in mm

Connector dimensions [mm]

without flange
without coding

with flange
with coding

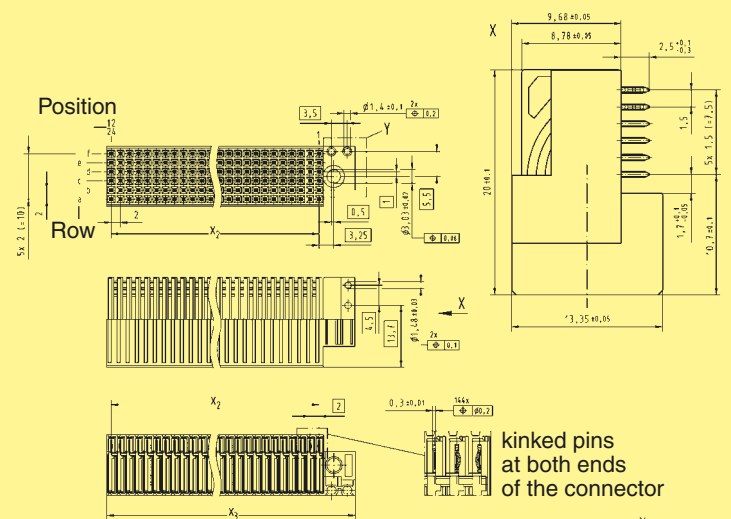
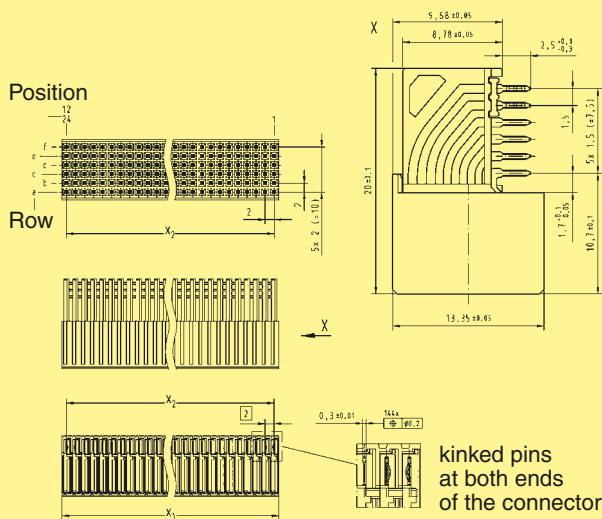

Contact positions	x ₁	x ₂	x ₃
72	24.0	11 x 2 (= 22)	31.0
144	48.0	23 x 2 (= 46)	55.0

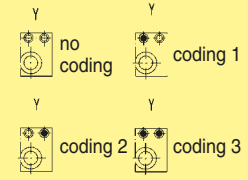

Board drillings

Board drillings

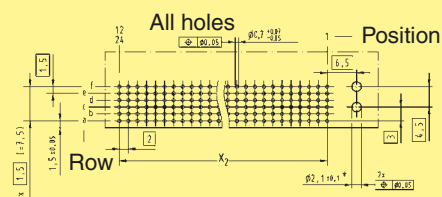
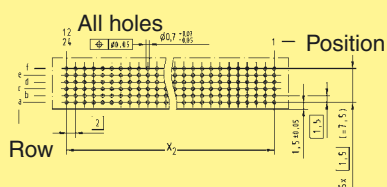

* Non-metallized drillings

HARTING is a supporter member of OBSAI since September 2003.

The Open Base Station Architecture Initiative (OBSAI) has developed a comprehensive set of open specifications for key module interfaces within the base station architecture. This development will enable an open market of base station modules.

The OBSAI architecture provides a clear split in functionality and detailed internal interface specifications. This allows companies to create modules that are truly compatible in all OBSAI compliant base stations. OBSAI provides the entry for a new, competitive market for functionally standardized modules.

HARTING's *har-bus*® *HM* Signal and *HM* Power connectors meet OBSAI specifications and provide a reliable and cost effective solution for connecting plug-in units to the backplane. The connector solution available from HARTING technology group will offer full compatibility and intermateability with base station modules.

HARTING's activities in the wireless market are in line with those of OBSAI.

The OBSAI specifications allow HARTING the opportunity to support a large group of wireless base station manufacturers and module manufacturers with unified, state of art interconnection solutions.

