

harbus[®] HM Power – general information	03.02
Technical characteristics	03.03
Angled male connectors with press-in termination	03.04
Angled male connectors with solder (SMC) termination	03.05
Straight female connectors with press-in termination	03.06

The *har-bus*® HM Power connector is designed according to the OBSAI Specification V 1.1. It is well suited to be used in conjunction with 2 mm *har-bus*® HM connectors. The durability is according IEC 61076-4-101 (250 mating cycles).

The straight male connector for the backplane is fitted with press-in contacts, the right angle male connector for daughter cards can be supplied with either, press-in or PIHIR (Pin In Hole Intrusive Reflow) termination.

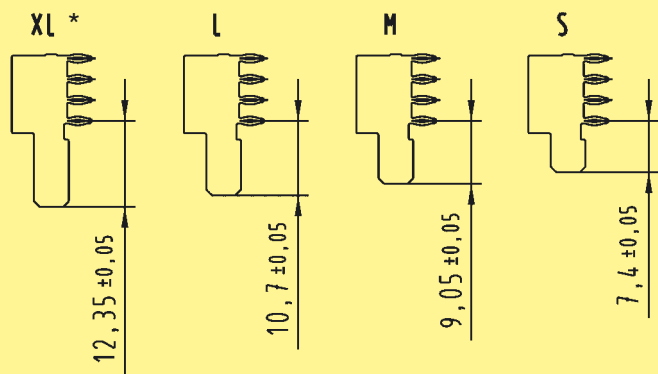

The compact, high temperature moulding can be loaded with up to four high current contacts. Four different contact lengths are available from 7.4 mm to 12.35 mm. This makes sequenced and non sequenced loadings possible (e.g. with GND and ENA). Any other contact assignments, also partially loaded, are possible on request.

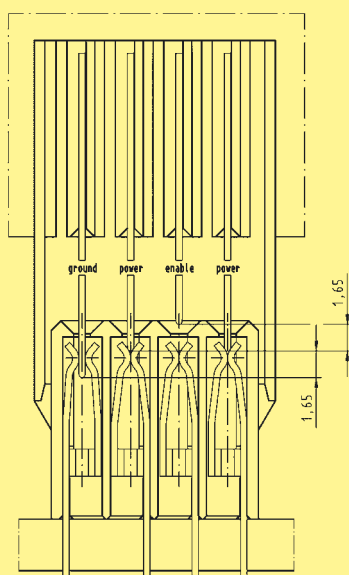

Loaded with four power contacts, each contact can carry up to 20 A @ 70 °C / 80 % derating. With a configuration of two power contacts, GND and ENA, the current carrying capacity is even up to 23 A @ 70 °C / 80 % derating per contact.

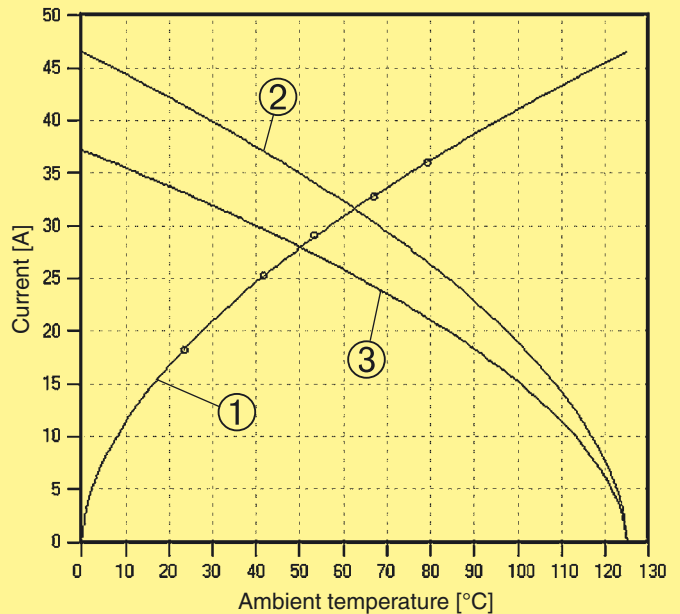

- ① Temperature raise
- ② Derating
- ③ Derating curve at $I_{max} \times 0.8$ (DIN EN 60512-5-2)

The distance between adjacent contacts is 3 mm, which enables wider pcb traces, larger solder paste areas and an improved heat dissipation. For the female backplane connector no special tooling is necessary due to the flatrock design.

HARTING's *har-bus*® HM Signal and Power connectors meet OBSAI (Open Base Station Architecture Initiative) specifications and provide a reliable and cost effective solution for connecting plug-in units to the backplane. The connector solutions available from the HARTING technology group will offer full compatibility and intermateability with base station modules.

Benefits:

- Small form factor
- High current rating up to 23 A per contact
- 3 level staggering (or even 4)
- Flatrock design
- Matched with *har-bus*® HM 2 mm connectors

harbus® HM Power

* Type XL on request

Design according	: OBSAI System Spezifikation V 1.1
Number of contacts	: 4
Contact spacing	: 3.00 mm
Clearance and creepage distances between contacts	: > 2.3 mm
Working current	: 23 A max.
Test voltage $U_{r.m.s.}$: AC 1500 V min.
Contact resistance	: < 1 m Ω
Insulation resistance:	: > 10 G Ω
Temperature range	: - 55 °C ... + 125 °C
during reflow soldering	220 °C for 2 minutes, 260 °C max. short-term
Durability as per IEC 61 076-4-101	: <i>Performance level 2 = 250 mating cycles in total.</i> First 125 mating cycles, then 4 days gas test using 0.5 ppm SO ₂ and 0.1 ppm H ₂ S (at 25 + 2 °C and 75 + 3 % humidity). Measurement of contact resistance. The remaining 125 mating cycles are subject to measurement of contact resistance and visual inspection. No abrasion of the contact finish through to the base material. No functional impairment.
Termination technique	
Male connectors	: Press-in or solder termination, suitable for (lead-free) pin-in-hole reflow soldering
Female connectors	: Press-in termination
Mating force	: max. 4 N / contact
Withdrawal force	: min. 0.5 N / contact
Materials	
Mouldings	: Thermoplastic resin, glass-fibre filled, UL 94-V0
Contacts	: Copper alloy
Contact surface	: Selectively gold plated (contact zone)
Contact styles	: Standard, leading, lagging
Packaging	
Tube	: Male and female press-in connectors
Tape & Reel	: Male solder connector



Male connectors angled, with press-in termination

Identification	Number of contacts	Contact length [mm] termination side	Part number	Contact loading
Connector with same sized contacts	4	2.8	17 61 004 2102	 Position — 4 3 2 1
Connector with same sized contacts	4	2.8	17 61 004 2103	 Position — 4 3 2 1
Connector with leading/lagging contacts	4	2.8	17 61 004 2101	 Position — 4 3 2 1

Contact dimensions [mm]

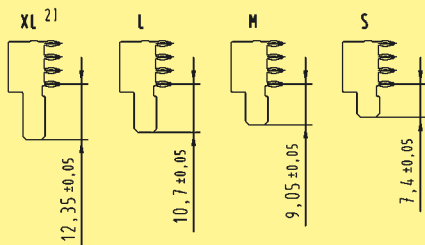

Connector dimensions [mm]

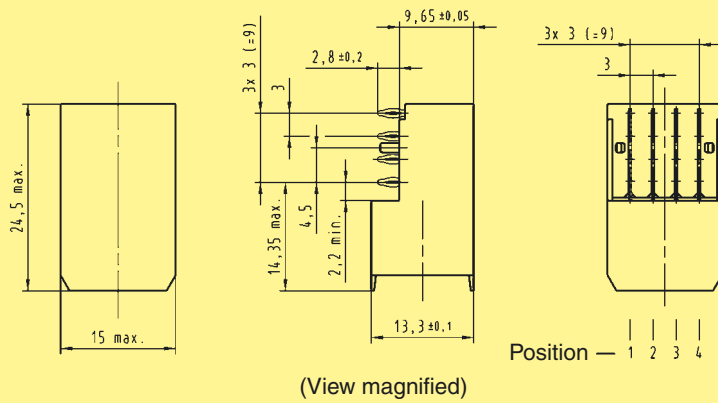

Board drillings

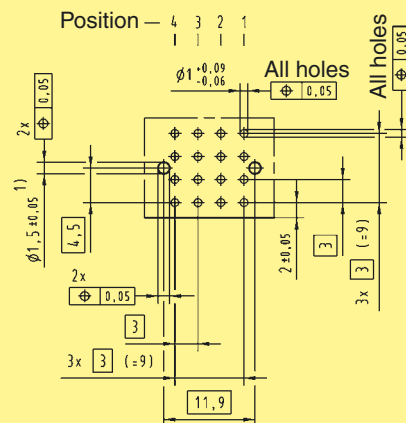

1) Non-metallized drillings
2) Type XL on request



Male connectors angled, with solder (SMC) termination

Identification	Number of contacts	Contact length [mm] termination side	Part number	Contact loading
Connector with same sized contacts	4	2.5	17 61 004 2802	 Position — 4 3 2 1
Connector with leading/lagging contacts	4	2.5	17 61 004 2801	 Position — 4 3 2 1

Contact dimensions [mm]

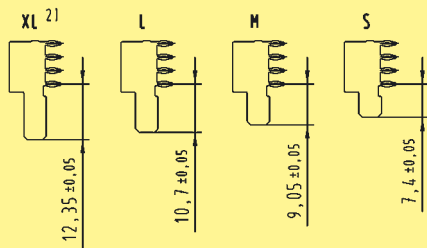

Connector dimensions [mm]

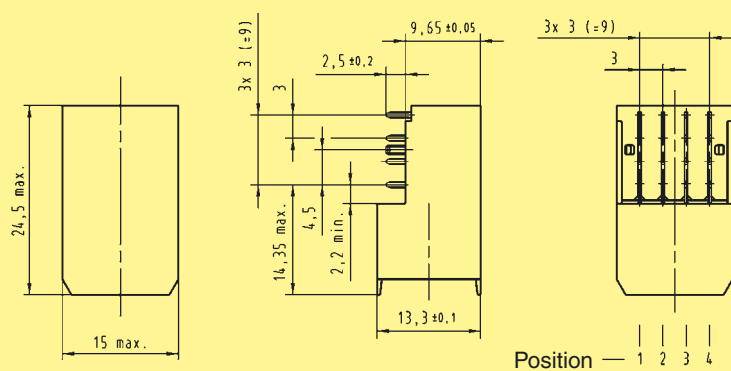

(View magnified)

Board drillings

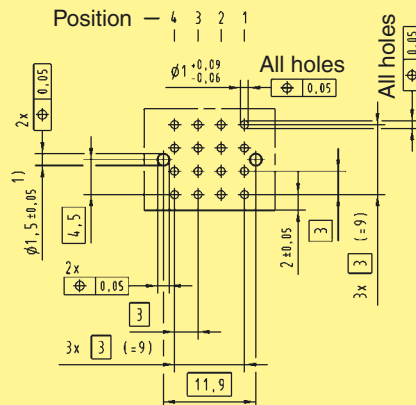

1) Non-metallized drillings
2) Type XL on request



Female connector straight, with press-in termination

Identification	Number of contacts	Contact length [mm] termination side	Part number
Connector with same sized contacts	4	3.7	17 66 004 2201

Connector dimensions [mm]

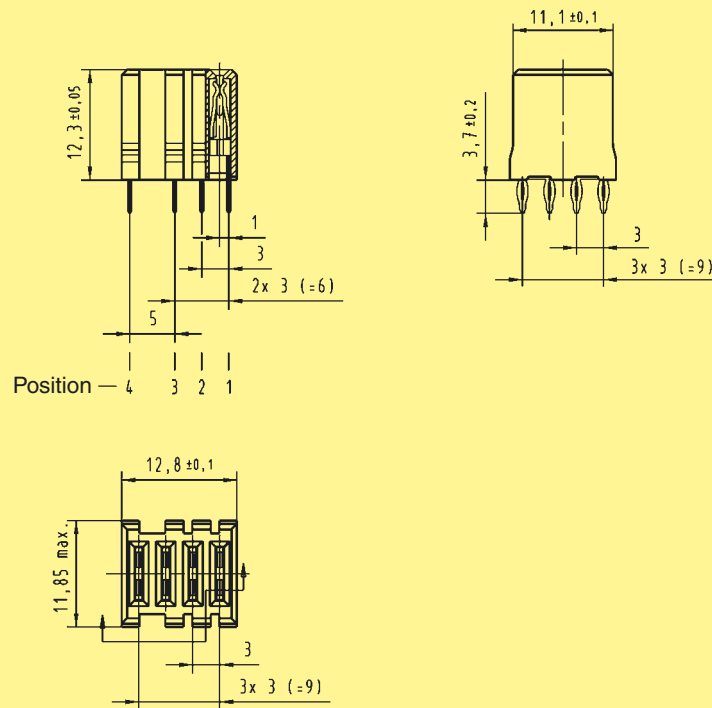

Board drillings

