

Industrial interfaces

Page

*Solutions for Ethernet*

Ethernet – General information ..... 11.02

Industrial Outlet ..... 11.09

System cables ..... 11.16

Connectors ..... 11.32

Tooling ..... 11.52

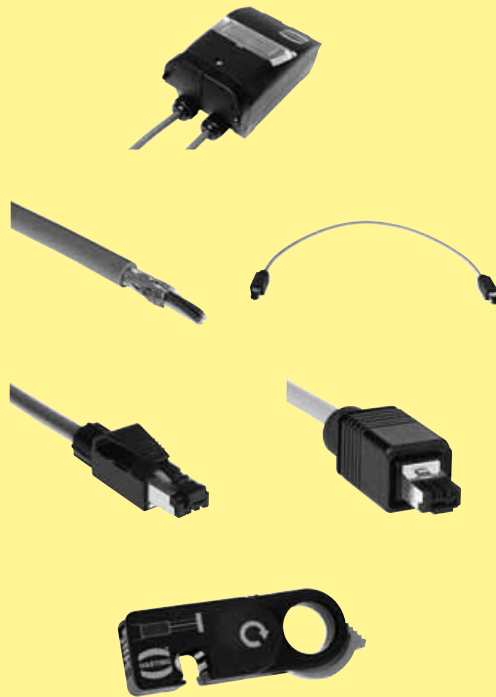

*Solutions for power supply*

Han® PushPull Power – General information ..... 11.54

Connectors ..... 11.56

Tooling ..... 11.60



## What is Ethernet?

Ethernet is a well established specification for serial data transmission, originally published by Xerox in 1975. In 1985 Ethernet was standardized in IEEE 802.3, since when it has been extended a number of times. "Classic" Ethernet operates at a data transmission rate of 10 Mbit/s.

Since the 1990s, Ethernet has developed in the following areas:

- Transmission media
- Data transmission rates
  - Fast Ethernet at 100 Mbit/s (1995)
  - Gigabit Ethernet at 1 Gbit/s (1999)
  - There are plans for Ethernet running at 10 gigabits
- Networked topologies
  - Switched Ethernet
- Industrial Ethernet

Nowadays Ethernet is the most widespread base technology in the world in commercial DP systems, and is also gaining importance in industrial automation. The use of Ethernet creates a homogenous and standardized communication infrastructure, extending seamlessly from the office environment to the machine.

## Classic Ethernet (Shared Ethernet)

All network users have the same rights under Ethernet. Any user can exchange data of any size with another user at any time.

Because Ethernet was conceived as a logical bus system, any network device that is transmitting is heard by all other users. Each Ethernet user filters the data packets that are intended for it out from the stream, ignoring all the others. Telegrams that are intended for all devices are an exception to this rule. These are known as broadcast or multicast telegrams.

## The CSMA/CD network access procedure

In Classic Ethernet, also frequently called shared Ethernet, all the network users share one collision domain. In Ethernet, network access is controlled by the CSMA/CD procedure (Carrier Sense Multiple Access with Collision Detection).

If a network user wishes to transmit data, it first checks whether the network is free (carrier sense). If so, it starts to transmit data. At the same time it checks whether other users have also begun to transmit (collision detection). If that is the case, a collision occurs. All the network users concerned now stop their transmission, wait for a period of time determined according to a randomising principle, and then start retransmission.

The result of this is that the time required to transmit data packets depends heavily on the network load, and cannot be determined in advance. The more collisions occur, the "slower" the entire network becomes. Shared Ethernet therefore only has limited suitability for industrial automation.

The physical size of the network is also limited. It depends on the data transmission rate being used and on the maximum permissible transmission time of data packets.

## Approaches to improved performance

A number of approaches have been tried to improve performance:

Segmentation: -> subdividing the collision domains

Higher

bandwidths: -> Fast Ethernet, Gigabit Ethernet

Switching: -> Switched Ethernet

and combinations of these.

Only with the implementation of these approaches does Ethernet become interesting and useful for industrial automation. For this reason, only Switched Ethernet and Fast Ethernet will be considered further in the following chapters.

Ethernet installations are primarily characterised by two parameters: the Category of the cable (Category) and the Class of the channel (Class).

## Ethernet transmission media in common use

Description	Meaning	Distance
<b>10 Mbit/s system</b>		
10 Base T [FD]	2 conductor pairs, min. Category 3, UTP and STP	>100 m
10 Base FX [FD]	Fibre-optic cable	Depends on fibre type
<b>100 Mbit/s system (Fast Ethernet)</b>		
100 Base TX [FD]	2 conductor pairs, Category 5, UTP and STP	100 m
100 Base FX [FD]	Fibre-optic cable	Depends on fibre type

[FD] = Full-duplex operation possible

The cable is identified by its Category in accordance with its electrical transmission and high-frequency properties, as follows:

- Category 1: not specified
- Category 2: up to 1 MHz
- Category 3: up to 16 MHz
- Category 4: up to 20 MHz
- Category 5: up to 100 MHz
- Category 6: up to 250 MHz
- Category 7: up to 600 MHz

The channel is the point-to-point part of the transmission process, and is specified as follows:

- Class A: up to 100 kHz
- Class B: up to 1 MHz
- Class C: up to 16 MHz
- Class D: up to 100 MHz
- Class E: up to 250 MHz
- Class F: up to 600 MHz

The higher the alphabetical sequence of the letter, the tougher are the requirements on the transmission channel, and therefore also on the cable. If, for instance, only Category 5 components are used in a system, the capacity of a Class D cable is required. The same applies to Category 6 and Class E, as to Category 7 and Class F.

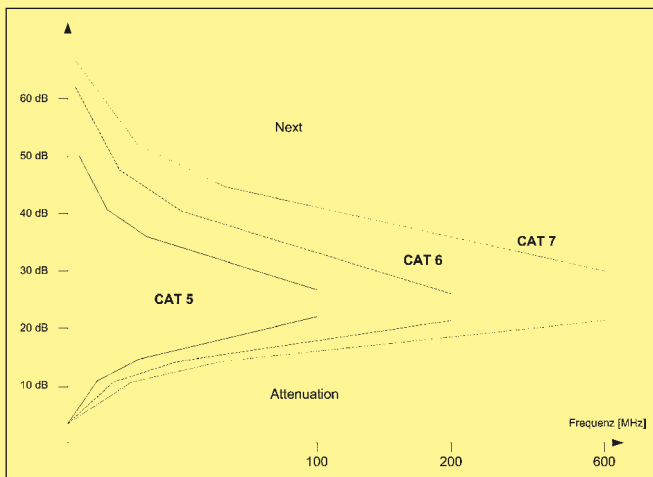

Next = Near end crosstalk

### Fast Ethernet

Fast Ethernet, according to IEEE 802.3u, is not a new standard, but an extension of Classic Ethernet to include the following new properties:

- A data rate of 100 Mbit/s
- Switching
- Full duplex operation

These form the basis of industrially useful Ethernet networks. Autonegotiation provides compatibility with Classic Ethernet in accordance with IEEE 802.3.

### Switched Ethernet

#### Definition

Switched Ethernet refers to a network in which each Ethernet user is assigned a port in a switch.

Switches separate former collision domains into individual point-to-point connections between the network components and the relevant user equipment.

Preventing collisions makes the full network bandwidth available to each point-to-point connection. The second pair of conductors in the Ethernet cable, which otherwise is necessary for the detection of collisions, can now be used as an additional transmission medium, so providing a significant increase in data transfer rate.

The use of switches allows any desired network configuration, such as star, ring, tree or linear, to be implemented.

#### Switched Ethernet offers the following important advantages:

- The possibility of scaling the collision regions to match the needs of the application, going as far as fully collision-free networks in which only one user is assigned to each port
- Very fast packet transfer between the collision regions
- A considerable increase in data transfer rate through "true" full duplex operation
- Preventing collisions allows deterministic operation

#### Network size

There is no theoretical limit to the physical extent of a Switched Ethernet network. The maximum length of conductor between the ends of a point-to-point connection is only determined by the physical transmission properties and is, according to the specification, 100 m. In practice, the connectors and cables used have a decisive effect on the transmission length that can actually be achieved.

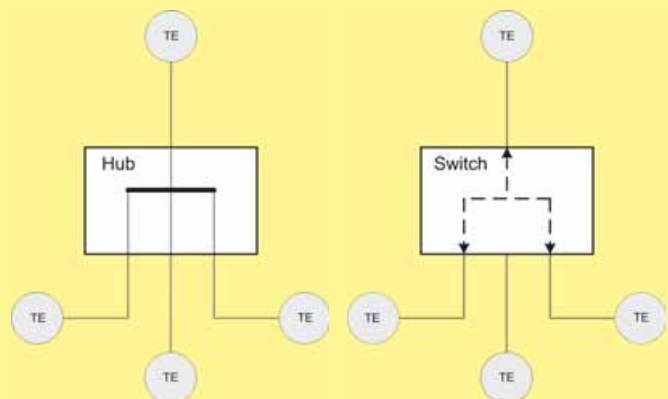

TE = Terminal Equipment

### The Industrial Ethernet network

#### General requirements for Industrial Ethernet networks

The international standard ISO/IEC 11801 and its European equivalent, EN 50173, define an application-neutral standard form of information networking for a building complex. The contents of the two standards are largely identical. Both standards assume that the buildings are used in a way similar to an office, and aim to be neutral towards particular

applications. The specific requirements for Ethernet networks in industrial environments, such as

- equipment-specific cabling
- individually adapted levels of networking for each machine/plant
- linear network structures
- robust, industrial cables and connectors meeting special requirements for EMC, temperature, humidity, dust and vibration

are considered in the future EN 50 173-3.

	Office areas	Production and other industrial areas
Installation conditions	<ul style="list-style-type: none"> <li>• Fixed basic installation in the building</li> <li>• Cables laid in false floor</li> <li>• Devices connected at workstation vary frequently</li> <li>• Prefabricated connecting cables</li> <li>• Largely standard work places (desk with PC, ...)</li> <li>• Tree network structures</li> </ul>	<ul style="list-style-type: none"> <li>• Wiring depends heavily on the equipment</li> <li>• Equipment-specific cabling</li> <li>• Connection points are rarely modified</li> <li>• Device connections may be assembled on site</li> <li>• Each machine/plant requires individual levels of networking</li> <li>• Linear or (redundant) ring network structures are common</li> </ul>
Transmission capacity	<ul style="list-style-type: none"> <li>• Large data packets (e.g. images)</li> <li>• Medium network availability</li> <li>• Transmission time on the scale of seconds</li> <li>• Predominantly acyclic transmission</li> <li>• No isochronism</li> </ul>	<ul style="list-style-type: none"> <li>• Small data packets (measurement data)</li> <li>• Very high network availability</li> <li>• Transmission time on the scale of microseconds</li> <li>• High proportion of cyclic transmission</li> <li>• Isochronism</li> </ul>
Environmental requirements	<ul style="list-style-type: none"> <li>• Moderate temperatures</li> <li>• Low dust levels</li> <li>• No humidity</li> <li>• Little shock or vibration</li> <li>• Low EMI exposure</li> <li>• Low mechanical hazard</li> <li>• Low UV radiation</li> <li>• Very little chemical hazard</li> </ul>	<ul style="list-style-type: none"> <li>• Extreme temperatures</li> <li>• High dust levels</li> <li>• Humidity possible</li> <li>• Vibrating machines</li> <li>• High EMI exposure</li> <li>• Risk of mechanical damage</li> <li>• UV exposure out of doors</li> <li>• Chemical hazard from oily or aggressive atmospheres</li> </ul>

Table: Differing requirements of office and industrial areas

### Transmission system and wiring

Industrial installation guidelines like “PROFINET” define a method of cabling for Industrial Ethernet, suitable for industrial application, on the basis of the fundamental requirements of ISO/IEC 11801.

These guidelines set new standards, because:

- The component manufacturer is provided with unambiguous interface specifications
- The user is provided with simple rules for the installation
- He is therefore able to implement networks without additional Ethernet-specific planning, as with a field bus.

Industrial installation guidelines specify cables and connectors with which the user can create an installation without special calculations relating to the transmission routes.

Detailed information can be found on the internet under [www.profinet.com](http://www.profinet.com)

### Cabling

Cables in an industrial environment may be exposed to extreme mechanical stresses. To ensure adequate mechanical protection special industrialised cable may be required, and this can have an effect on

the transmission properties, which may mean that only relatively short transmission routes can be implemented. Signal transmission along symmetric copper cables (twisted pair) must be in accordance with 100 BASE-TX at 100 Mbit/s (Fast Ethernet). The transmission medium contains two pairs of twisted, screened copper cables (twisted pair or star quad) with a characteristic impedance of 100 Ohms. The individual components must satisfy the requirements for Category 5 in accordance with ISO/IEC 11801. The entire transmission route must satisfy the requirements for Class D in accordance with ISO/IEC 11801. Removable connections on the cable side are made using RJ 45 connectors. On the device connections are in the form of female mating connectors. Connecting cables (device connecting cables and routing cables) accordingly have male connectors at both ends. Each device is connected through an active network component. The transmission cable therefore has identical connectors at both ends which simplifies installation as the connecting cable fulfils the function of a patch lead. The maximum cable length is 100 m.

As long as the cable and the connectors meet with the above specifications for a PROFINET compliant installation, a maximum cabling length of 100 m can be achieved with up to six connector pairs. The combination of a male and female connector is regarded as one pair.

Wiring example	Number of connector pairs	Maximum cabling length
	2	100 m
	2	100 m
	2	100 m
	4	100 m
	4	100 m
	6	100 m
	6	100 m

TE = Terminal Equipment  
 PMD = PROFINET Machine Distributor

Area "inside"

Connector

Connector coupling

Table: Transmission route lengths

## Connectors

An important criterion for industrial applications is the ease with which connection equipment can be handled on site. Connectors for RJ 45 are available for this purpose. They can easily be assembled on site using standard tools.

In the control cabinet area, RJ 45 connectors are used in an IP 20 implementation. It is compatible with office connectors.

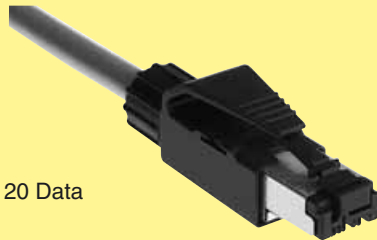

HARTING RJ Industrial® IP 20 Data

Connectors outside the control cabinet must be capable of withstanding the stresses of industrial applications. RJ 45 connectors with protection to IP 65 or IP 67 are used in this environment. The RJ 45 in IP 65 / IP 67 implementation has a robust housing with Push Pull locking. Special versions allow a level of protection up to IP 68 to be achieved.



Han® PushPull S connector

Hybrid connectors can be used where distributed field devices require connection to both the data network and to a low voltage power supply. A fully contact-protected connector allows the connectors to be identical at both ends, since the integrated contact protection means that it is not necessary to alternate between male and female contact. An RJ 45 providing IP 67 protection is used to connect twin-pair, screened data lines for communication and four electrical contacts provide connection to the power supply.



HARTING RJ Industrial® IP 67 Hybrid

## Connector assignment

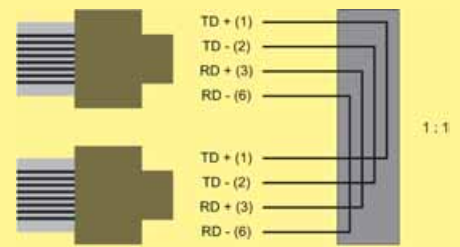

RJ 45

Signal	Function	Conductor colour	Pin assignment RJ 45
TD+	Transmission Data +	Yellow	1
TD-	Transmission Data -	Orange	2
RD+	Receiver Data +	White	3
RD-	Receiver Data -	Blue	6

## Industrial Outlets

The interface between the structured building network in accordance with ISO/IEC 11801 and the industrial plant cabling is provided by the Industrial Outlet, or InO. Its function corresponds to the socket outlet used in the office environment. The InO is manufactured to meet protection levels IP 65 / IP 67 and is suitable for the harsh conditions found in the industrial environment. For a safe and easy handling the Outlet is fitted with two Push Pull interfaces.



## Gigabit Ethernet in structured building cabling

The Ethernet cable used in structured building cabling is also finding a wide range of applications in industrial environments. Even today, entire production cells and machinery are connected with Fast Ethernet to the existing building cabling.

The change from field bus networks to 100 Mbit Fast Ethernet networks itself provides the user with several times the bandwidth. In comparison with Fast Ethernet, Gigabit Ethernet multiplies the bandwidth a further 10 times.

The currently applicable standards for structured building cabling are:

- ISO/IEC 11801:2002 (international standard)
- EN 50173-1:2002 (European standard)
- DIN EN 50173-1:2002 (German standard)
- TIA/EIA 568:2002 (North American standard)

Gigabit Ethernet exploits structured cabling differently from 10/100 Mbit/s Ethernet.

The most important difference is this: Gigabit Ethernet uses all four pairs of conductors in full duplex mode, i.e. for communication in both directions simultaneously, in order to keep the bandwidth per conductor, required for transmission as low as possible.

### Access procedure

In addition to the larger bandwidth, one of the advantages of Gigabit Ethernet is that the structure of the data packets and the access procedure are identical to those of Fast Ethernet and Ethernet, with the consequence that hardly any changes are needed to the network operating systems or to the application and management software.

Gigabit Ethernet, like the existing IEEE 802.3 (10 Mbit/s) and IEEE 802.3u (100 Mbit/s) Ethernet standards, uses the Carrier Sense Multiple Access with Collision Detection (CSMA/CD) collision protocol.

### Topologies

Because the network operating systems necessary for Gigabit Ethernet are identical, the network topologies described in ISO IEC 11801 have been adopted. It is therefore not necessary to change the installations from 100 Mbit Fast Ethernet to 1000 Mbit Gigabit Ethernet. The physical components, e.g.

is the cables and connectors, must, however, be appropriate for the higher bandwidth. For this reason, almost all buildings nowadays are fitted with Gigabit Ethernet cabling, even though most of the devices that are connected to this cabling are only equipped with a 100 Mbit Fast Ethernet protocol chip. However, because the demand for bandwidth can be expected to increase in future, this type of cabling offers the most secure path for future upgrades.

### Copper wire

The Gigabit Ethernet cables for the tertiary level (horizontal wiring) of cabling structured in accordance with EN 50173-1:2002 are individually shielded twisted pairs in which the strand bunches have a diameter of AWG 22 - AWG 24. The pair as a whole may also be shielded, depending on the needs of the application. The use of twisted pairs with an additional shield for each conductor provides even better and cleaner differential signal transmission than ordinary twisted pair cables (where the individual conductors are not shielded), and should eliminate common mode interference.

The cables are classified as follows:

SF/UTP Shielded Foiled / Unshielded Twisted Pair cable (see Figure 1)

S/FTP Shielded / Foiled Twisted Pair cable (see Figure 2)

Figure 1: SF/UTP cable

Figure 2: S/FTP cable

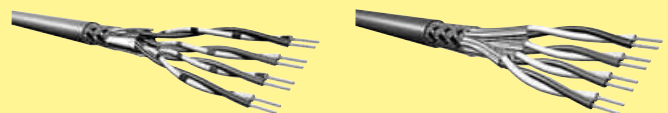

These service-neutral cables are capable of transmitting the following protocols:

- Ethernet 10 BaseT
- Fast Ethernet 100 BaseT
- Gigabit Ethernet 1000 BaseT
- ATM 155 Mbit/s
- TP-PMD 125 Mbit/s
- Cable sharing (using the same or different services)
- CDDI/TPDDI (FDDI over copper)
- Token Ring at 4/16 Mbit/s
- Analogue telephone services, ISDN

The service to be carried depends on the pin assignment (see summary on page 11.08).

RJ 45 pin assignment of different networks:

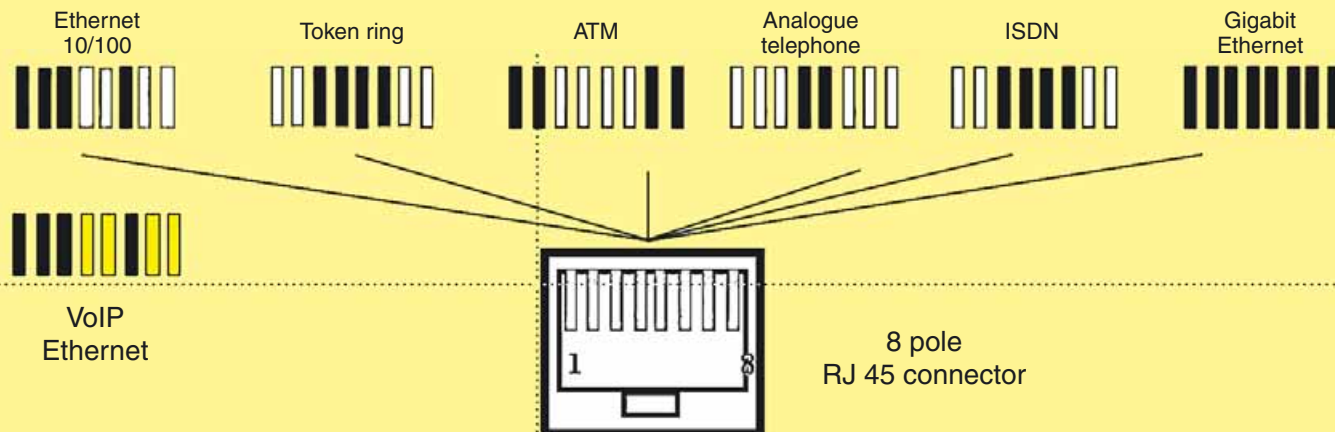

Figure 3: Pin assignment

The four free contacts in 100 Mbit Fast Ethernet wiring are often used to supply power to the end device.

The cables and connectors used must satisfy the requirements of ISO/ IEC 11801:2002.

2 classes of wiring are distinguished:

- Fast Ethernet at 100 Mbit/s
- Gigabit Ethernet at 1000 Mbit/s

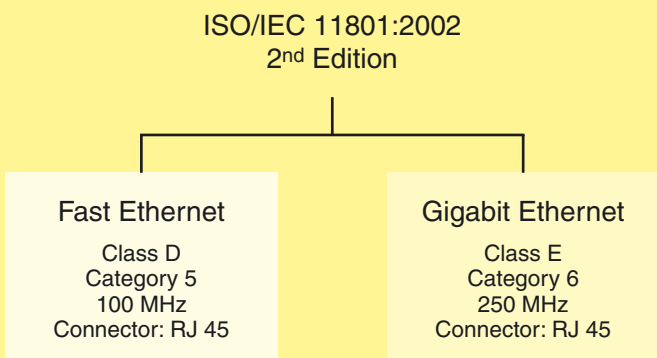

For a transmission route with Fast Ethernet this means:

- Class D cables (100 MHz) are used together with a Category 5 (100 MHz) connector.

A transmission route with Gigabit Ethernet uses:

- Class E cables (250 MHz) together with a Category 6 (250 MHz) connector.

**Connectors**

The RJ 45 connectors used with Gigabit Ethernet must have 8 contacts for the 4 pair cable. These contacts must meet the high requirements of a Category 6 component. This is only possible with a perfect interplay between the individual components of the connector (contacts and insulator), and a perfect connection of the Class E cables. The pin assignment has been designated for contact pairs 1-2, 3-6 and 4-5, 7-8, because of the round geometry of the cable and the relative positions of the cores associated with this.

A tool is required to connect the cable by forcing the piercing contacts through the outer jacket of the conductor so as to make the electrical contact. This tool must be matched specifically to the connector, as a reliable contact cannot otherwise be guaranteed. In order to meet the high requirements of the transmission route it is also necessary to locate the shield of each individual conductor in the twisted pairs as closely as possible to the connector's insulator. This minimises crosstalk between the data signals within the connector.

Industrial interfaces



Industrial Outlets



## General description

### The Industrial Outlet as an interface between office and factory floor

Effective communication is becoming more and more of a crucial factor in competitive business life. Existing office networks are therefore increasingly being sewn together with industrial machine networks to link the production area into structured building cabling.

This presents the user with the need for vertically integrated wiring, and for defined transition areas that take the requirements of the two environments into account. The Industrial Outlet provides the transition within this kind of cross-level wiring.

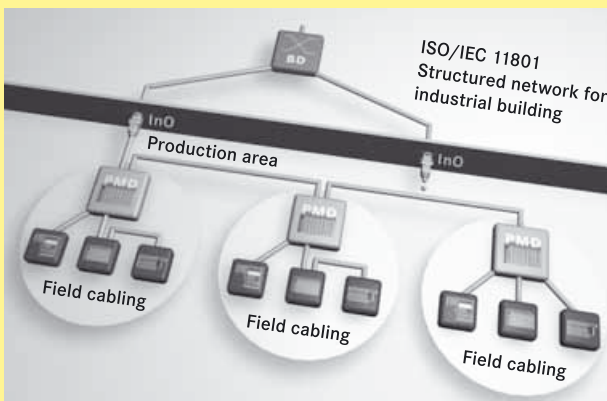

The Industrial Outlet permits structured building cabling in accordance with ISO/IEC 11801:2002 or with EN 50173:2002 to be continued in the industrial environment through to the machine. In addition the RJ 45 interfaces with Push Pull locking mechanism fulfill the future standards for generic, industrial building cabling in accordance with ISO/IEC 24 702.

With its robust housing the outlet is applicable in every environment with demands beyond the office area:

- Laboratories
- Workshops
- Assembly, storage and shipment departments
- Production facilities
- Transport and logistic centres

By the easy on-wall mounting the outlets can be smoothly installed on walls, pillars, beams or production cells and be connected to the building network cable (horizontal cable).

The proven LSA-PLUS® connection system lets the installer install the cable quickly and easily. The Industrial Ethernet cabling for equipment and machines is continued through to the production level using pluggable RJ 45 connectors.

HARTING has developed a family of products for this purpose, RJ Industrial, which is ideally adapted to the machine network whilst nevertheless remaining compatible with common office standards.

The Han® PushPull outlet provides an interface to the specified Industrial Ethernet cabling in accordance with PROFINET.

## Advantages

- High IP 65 / IP 67 protection level
- Category 6 for Gigabit Ethernet
- Robust housing
- Can be used directly in industrial environments
- Easy on-wall mounting
- LSA-PLUS® connection technology makes installation straightforward
- Optimum connector technology with high data security
- Standardised interface in acc. with ISO/IEC 24 702 and IEC 61 076-3-106, variant 4.
- Label for individual customer marking

Category 6

Han® PushPull S Outlet

**Installation options**

The Han® PushPull Outlet consists of an impact resistant IP 67 plastic housing with two inlets for the building cable and two outlets for the field wiring with a Push Pull interface. The building cable can optionally be brought in from above or from below,

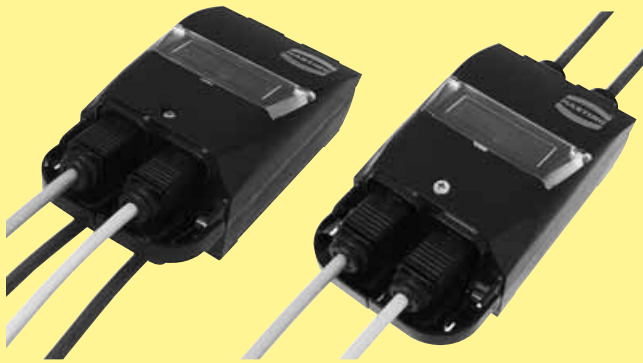

and the user is therefore given flexible options for mounting the outlet on walls, pillars, production cells and so forth. Hinges join the captive lid to the base.

**Push Pull interface with automatic protective flaps**

The Han® PushPull connector is used as an interface to the machine cabling. This connector needs 50% less space than any other RJ 45 connector in IP 67 available on the market. The Push Pull interface of the outlet is specified for PROFINET because of its compatibility with this connector. The Industrial Outlet is fitted with self-closing protective covers, because it is possible that at certain times no connector will be inserted. As soon as the connector is withdrawn, these covers close the outlet

automatically to protection class IP 67 / 65. In this way the socket is reliably protected at all times



without the need for additional covers. The Push Pull interfaces offer blind mating and they can be sealed against unauthorised connection. For test and diagnostic purposes, it is of course also possible to connect the HARTING RJ Industrial® IP 20 connector and usual standard RJ 45 connectors.

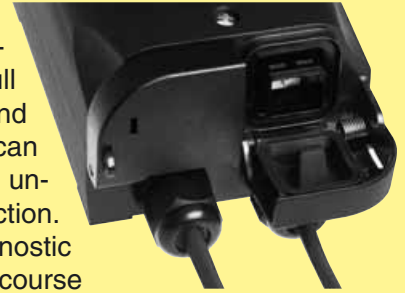

**Labelling in IP 67 environments**

So that the ports in a network can be clearly identified even under unfavourable environmental conditions, the Han® PushPull S Outlet includes an integrated transparent protective label cover. This allows the socket to be labelled even in an IP 67 environment. In this way the labelling on the sockets remains readable, even after years of use in industrial and outdoor areas.



**Time saved through field-proven LSA-PLUS® connection technology**

Time is one of the most critical factors in production. The assembly time for the outlet has therefore been reduced to a minimum. Markings on the cover and the base of the connection socket identify the specified cable lengths required for the connection. This allows the installer to determine the cable lengths and the length of insulation to be stripped quickly and easily. The building cable is attached with the aid of the



Han® PushPull S Outlet

proven KRONE KM8 socket module with LSA-PLUS® technology. This allows solid and flexible AWG 24-22 installation cables to be connected up to 200 times. The cable is connected directly via the connector. An additional PCB is not required. The user is therefore handling familiar technology. The connection is made entirely using standard tools. The unambiguous colour-coding according to EIA / TIA 568 A / B simplifies assignment of the individual conductors, and therefore reduces the working time. A die-cast zinc housing and a plug-in shielded spring shield the KRONE KM8 module all 360°.

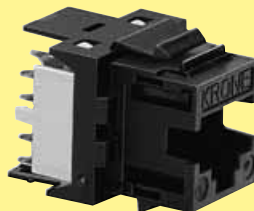

(Source: KRONE)

The most important feature of this keystone jacks is its Category 6 performance. This enables the use in Gigabit Ethernet applications.



**Integrated cable manager for secure, reliable cable guidance**

High transmission performance is further supported by an integrated cable manager. It assures the user that the installation cable is laid correctly according to the defined bending radii. Kinked cables, which can lead to faults in data transmission, are effectively avoided. The innovative design of the cable manager has made it possible to sharply reduce the external dimensions of the outlet whilst nevertheless



(Source: KRONE)

maintaining the bending radii necessary for Category 6 cables. This cable guide system also makes the installer's work easier, since he can be certain that the cable is following the correct path inside the housing. This reduces the amount of measurement work needed. It is also possible to introduce the building cable from above, simply by turning the cable manager and the housing cover through 180°.

The Han® PushPull S Outlet thus incorporates all the properties necessary for networking the office and field levels together simply and consistently. Thanks to the Category 6 performance, it represents a secure investment for the future. It can at the same time be installed anywhere, saving time and money. And finally, the entire system is packed into an attractive yet highly functional housing. For the different application fields it is available in black or in white.



## Installation Instructions

1. Mount the bottom part of the outlet. Use the enclosed template for the hole center distance.
2. Remove the cable manager.

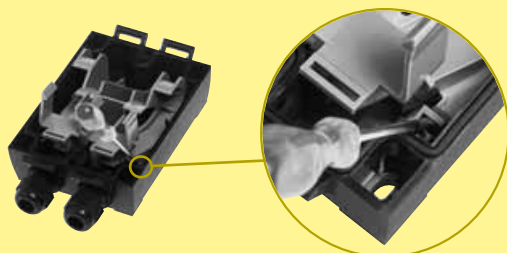

3. Attach the top cover to the bottom part, insert the cables from bottom or top side.

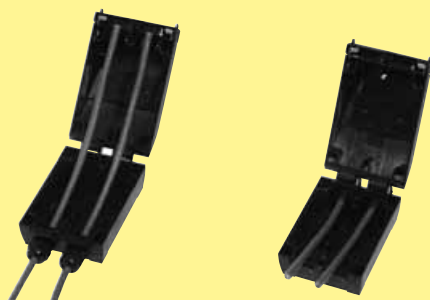

4. Strip the cable up to the marking inside the cover/ bottom part of the outlet and terminate it with the enclosed keystone jack (for instructions please see the packaging).



5. Insert the cable manager with the arrow pointing on- to the locking nose and engage it with an audible "CLICK".

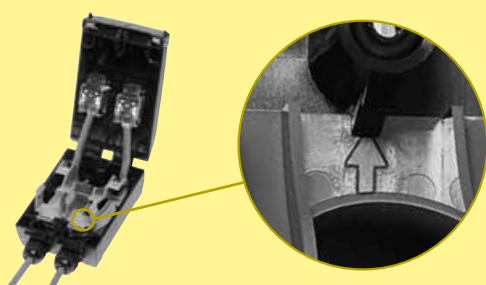

6. Insert the keystone jacks into the cable manager and engage them with an audible "CLICK". Make sure that the modules are seated correctly!



7. Close the top cover and tighten it. Recommended torque: 0.6 ... 0.8 Nm.



8. Close not used cable glands with the enclosed blind plug.

## Labelling

1. Disengage the cover of the label.



2. Insert a labelled paper (appr. 50 x 14 mm) and close the cover with an audible "CLICK".

## Locking

The protective flaps of the outlet can be locked against unauthorised plugging with two lugs.



Category 6



## Han® PushPull S Outlet

Description	Part No.	Drawing	Dimensions in mm
<p>IP 67 network outlet</p> <p>existing of:                      2 x Category 6 keystone jack                      1 x housing with protective flaps, cable management, label tag                      2 x cable gland                      1 x blind plug                      1 x instruction manual</p>			
Housing colour black	09 45 845 1500		
Housing colour white	09 45 845 1501		

## Advantages

- Universal solution for most industrial applications
- Meets the requirements of the IT department AND the production department
- Future-proof due to Category 6 de-embedded
- Flexible installation by cable feeding from bottom or top side
- The cable management avoids kinked cables
- Termination without special tools
- Easy one-hand locking and unlocking of the connector (Push Pull)
- Self-closing protective flaps
- Integrated IP 67 label tag for durable identification
- Standardised interface acc. to ISO/IEC 24 702 and IEC 61 076-3-106, variant 4



 Category 6

Han® PushPull S Outlet

## Technical characteristics

Transmission performance	Category 6 for class E links acc. to ISO / IEC 11801
Transmission rate	10 - 1.000 Mbit/s (Ethernet, Fast Ethernet and Gigabit Ethernet)
Transmission frequency	max. 250 MHz
Termination	2 x KRONE KM8 RJ 45 keystone jack, Category 6 vibration proof located
Wiring	IDC without special tools (2 x LSA-PLUS®) min. 200 times repairable
Strands diameter	AWG 24 - 22 solid and stranded 0.5 - 0.65 mm
Ø strands isolation	0.7 -1.6 mm
Sheath diameter	6 - 9 mm
Cable type	2- and 4-pair installation cables, Category 5, 6 and 7 acc. to IEC 11801
Cable feeding	1 to 2 cables from bottom or top side
Connector	Han® PushPull S acc. to ISO/IEC 24 702 and IEC 61 076-3-106, variant 4
Mating face	RJ 45 acc. to IEC 60603-7 compatible to all standard RJ 45 connectors
Mating cycles	min. 750
Shielding	360°
Mounting	On-wall mounting with 4 screws
Dimensions	152 x 90 x 69 mm
Protection degree	IP 67 and 65, mated and unmated by self-closing protective flaps
Ambient temperature	-20 °C...+70 °C
Housing material	Polycarbonate, shock-resistant halogen free, UV resistant, UL 94-V0
Colour	black, RAL 9011 white, RAL 9010
	UL recognised, E102079

Identification		Part No.	Ethernet termination
<b>Connector set Han® PushPull S</b>			
Han® PushPull S, 2 pairs		09 45 145 1100	
Han® PushPull S, 4 pairs		09 45 145 1500	

Identification		Part No.	Technical details
<b>System Cables for Industrial Ethernet, pre-assembled at both ends</b>			
Stranded System Cable for Industrial Ethernet	Length: 1.5 m	09 45 745 1523	Cable type: Industrial Ethernet Stranded Cable, Category 6, 4 x 2 x AWG 27/7, shielded twisted pair  Connectors: 2 x Han® PushPull S, 4 pairs, Category 6
	3.0 m	09 45 745 1525	
	5.0 m	09 45 745 1527	
	10.0 m	09 45 745 1551	
	20.0 m	09 45 745 1553	
	Length: 1.5 m		
3.0 m		09 45 745 1166	
5.0 m		09 45 745 1168	
10.0 m		09 45 745 1173	
20.0 m		09 45 745 1175	
50.0 m		09 45 745 1178	
100.0 m		09 45 745 1183	
Trailing System Cable for Industrial Ethernet	Length: 1.5 m	09 45 745 0023	Cable type: Industrial Ethernet Trailing Cable, 2 x 2 x AWG 22/7, star quad, double shielding  Connectors: 2 x Han® PushPull S with IDC termination and fast locking technology
	3.0 m	09 45 745 0025	
	5.0 m	09 45 745 0027	
	10.0 m	09 45 745 0051	
	20.0 m	09 45 745 0053	
	50.0 m	09 45 745 0056	
	100.0 m	09 45 745 0061	
Stranded System Cable for Industrial Ethernet	Length: 1.5 m	09 45 701 1164	Cable type: Industrial Ethernet Stranded Cable, 2 x 2 x AWG 22/7, star quad, double shielding  Connectors: 1 x Han® PushPull S, 1 x HARTING RJ Industrial® IP 20Data, both with IDC termination technology
	3.0 m	09 45 701 1166	
	5.0 m	09 45 701 1168	
	10.0 m	09 45 701 1173	
	20.0 m	09 45 701 1175	
	50.0 m	09 45 701 1178	
	100.0 m	09 45 701 1183	

### System cables

The cabling represents the backbone of a network. Mistakes during the selection and laying of cables may lead to serious errors in data transfer, data loss and even total network failure. Especially in the industrial environment, reliable and fully functional cables are a crucial element in planning and implementing high-performance networks ensuring a high degree of availability.

HARTING offers a wide range of diverse Ethernet cables, which are specially designed for use in a harsh industrial environment. Data transfer in the categories 5 and 6 to ISO/IEC 11801 is supported by means of solid, stranded, or hybrid cable, which may also be used in dynamic cable carriers. Oil resistance, high mechanical stability and halogen-free, are only a

few of the features HARTING demand from on its cables.

The combination of these industrial cables and the robust HARTING RJ Industrial® connectors results in high-grade and long-lasting system cables. The consistent application of a modular system to both for our connectors and system cables allows HARTING to cover a wide field of applications. HARTING offers a range from the compact molded IP 20 connectors up to robust IP 67 components. The matrix below shows the supported combinations.

HARTING offers Gigabit system cables with degrees of protection IP 20 and IP 67, for use in demanding applications to Category 6 or Class E.

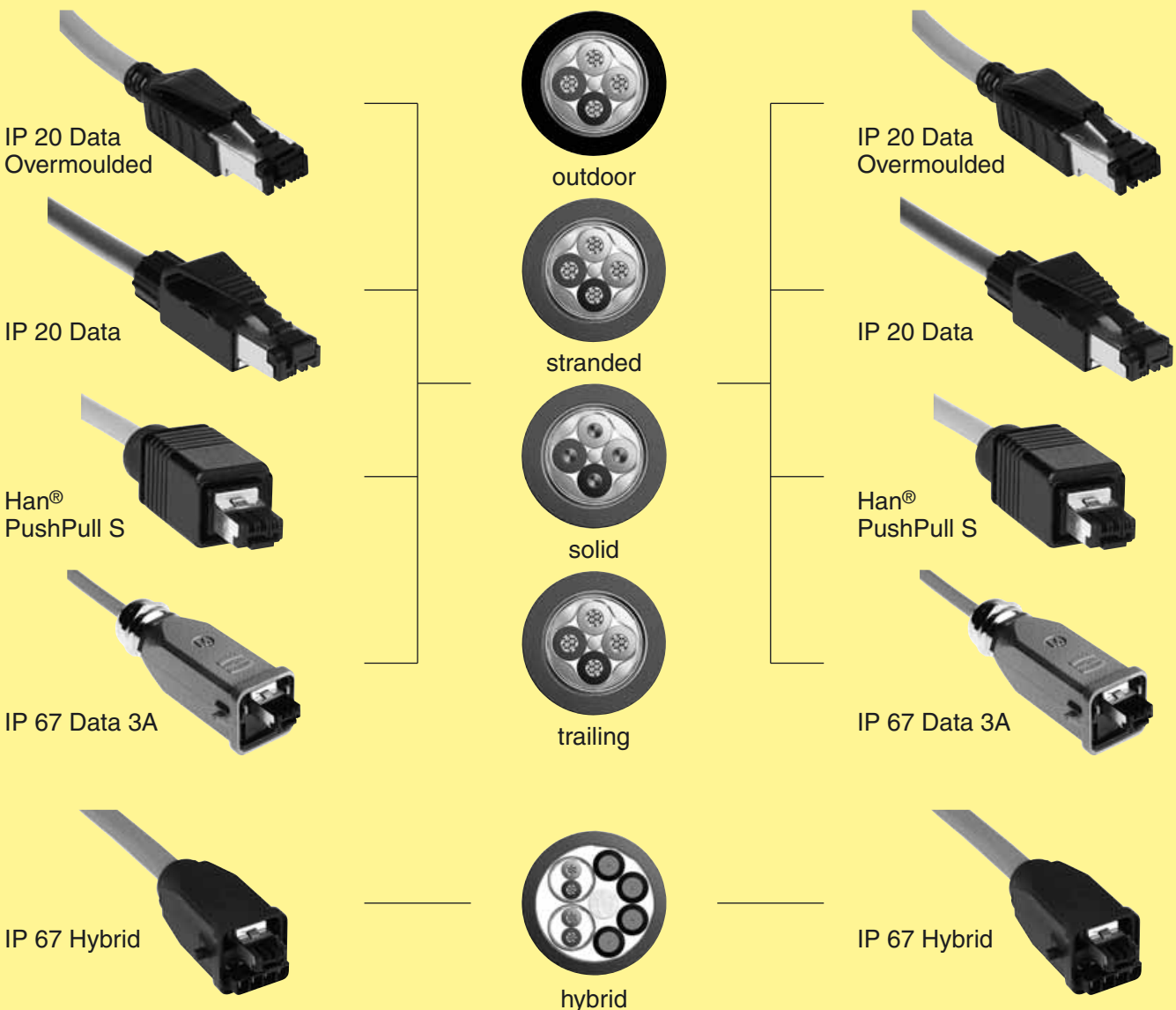

Customized system cables, in different lengths and selectable RJ Industrial connectors are available on request.

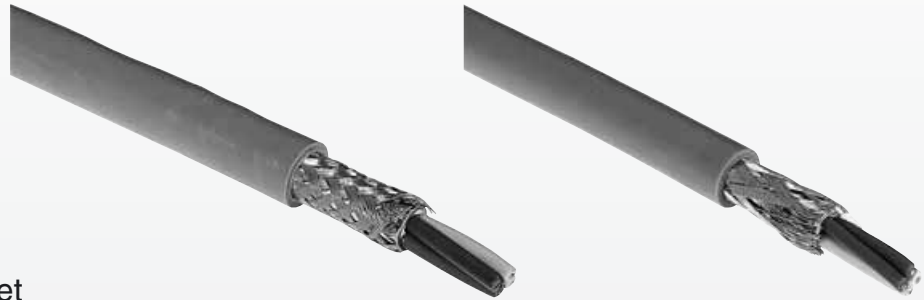

Industrial interfaces



## Cable for Industrial Ethernet

Description	Part No.	Technical characteristics
<p><b>PROFINET type A cable</b> for fixed installation</p>  <p>Length: 20 m 50 m 100 m 500 m</p>	<p>09 45 600 0130 09 45 600 0140 09 45 600 0100 09 45 600 0110</p>	<p>Cabling standard in acc. with ISO/IEC 11 801: Category 5</p> <p>Structure: radially symmetrical arranged as star quad, double shielding</p> <p>Sheath: PVC green, Ø 6.5 mm</p> <p>Cores: solid, 2 x 2 x AWG 22/1 (Ø 0.64 mm)</p> <p>Service temperature: -40 °C ... +70 °C</p> <p>Minimum bending radius: multiple bending 7.5 x Ø one time 3 x Ø</p> <p>Max. permissible tension: 150 N</p>
<p><b>PROFINET type B cable</b> for flexible installation</p>  <p>Length: 20 m 50 m 100 m 500 m</p>	<p>09 45 600 0132 09 45 600 0142 09 45 600 0102 09 45 600 0112</p>	<p>Cabling standard in acc. with ISO/IEC 11 801: Category 5</p> <p>Structure: radially symmetrical arranged as star quad, double shielding</p> <p>Sheath: PVC green, Ø 6.5 mm</p> <p>Cores: stranded, 2 x 2 x AWG 22/7 (Ø 0.75 mm)</p> <p>Service temperature: -40 °C ... +70 °C</p> <p>Minimum bending radius: multiple bending 5 x Ø one time 3 x Ø</p> <p>Max. permissible tension: 150 N</p>
<p><b>PROFINET type C cable</b> for power chains</p>  <p>Length: 20 m 50 m 100 m 500 m</p>	<p>09 45 600 0131 09 45 600 0141 09 45 600 0101 09 45 600 0111</p>	<p>Cabling standard in acc. with ISO/IEC 11 801: Category 5</p> <p>Structure: radially symmetrical arranged as star quad, double shielding</p> <p>Sheath: PUR green, Ø 6.5 mm</p> <p>Cores: stranded, 2 x 2 x AWG 22/7 (Ø 0.75 mm)</p> <p>Service temperature: -40 °C ... +70 °C</p> <p>Minimum bending radius: multiple bending 7 x Ø one time 3 x Ø power chain: 200 mm</p> <p>Max. permissible tension: 150 N</p>

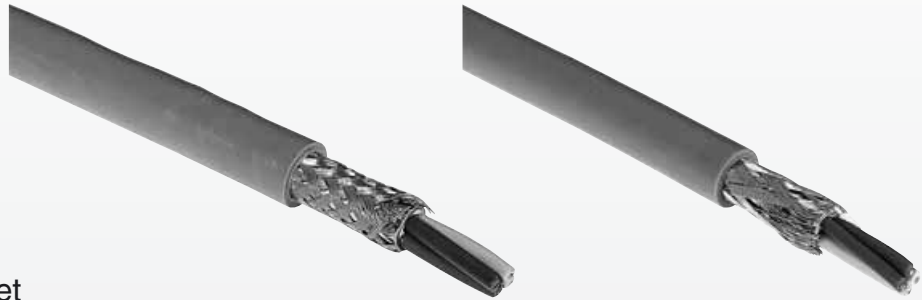

## Cable for Industrial Ethernet

### Description

### Part No.

### Technical characteristics

**PROFINET type B Hybrid cable**  
for flexible installation



Length: 20 m  
50 m  
100 m

09 45 600 0330  
09 45 600 0340  
09 45 600 0300

Cabling standard in acc. with ISO/IEC 11 801:

Structure:

Category 5

two wires twisted to a pair, double shielding, plus 4 power supply cores, filler as a central element

Sheath:

Data cores:

FRNC green, Ø 10.3 mm

stranded, 2 x 2 x AWG 22/7 (Ø 0.75 mm)

Power supply cores:

Service temperature:

Minimum bending radius:

Max. permissible tension:

stranded, 1.5 mm<sup>2</sup>

-20 °C ... +70 °C

multiple bending 10 x Ø  
one time 5 x Ø

200 N

**PROFINET type B cable**  
for flexible installation



Length: 20 m  
50 m  
100 m  
500 m

09 45 600 0135  
09 45 600 0145  
09 45 600 0105  
09 45 600 0115

Cabling standard in acc. with ISO/IEC 11 801:

Structure:

Sheath:

Cores:

Service temperature:

Minimum bending radius:

Max. permissible tension:

Category 5

radially symmetrical arranged as star quad, double shielding

PVC black, UV resistant, Ø 6.5 mm

stranded, 2 x 2 x AWG 22/7 (Ø 0.76 mm)

-40 °C ... +70 °C

multiple bending 5 x Ø  
one time 3 x Ø

150 N

Outdoor





## Cable for Industrial Ethernet

### Description

### Part No.

### Technical characteristics

**Industrial Ethernet cable, 4 pairs**  
for flexible installation



Length: 20 m  
50 m  
100 m

09 45 600 0133  
09 45 600 0143  
09 45 600 0103

Cabling standard in acc. with ISO/IEC 11 801: Category 5

Structure: two wires twisted to a pair, 4 pairs twisted with shielding foil

Sheath: PVC green, Ø 5.8 mm

Cores: stranded, 4 x 2 x AWG 26/7 (Ø 0.15 mm)

Service temperature: -20 °C ... +60 °C

Minimum bending radius: multiple bending 8 x Ø  
one time 4 x Ø

Max. permissible tension: 100 N

**Gigabit Ethernet cable, 4 pairs**  
for flexible installation



Length: 20 m  
50 m  
100 m  
500 m

09 45 600 0530  
09 45 600 0540  
09 45 600 0500  
09 45 600 0520

Cabling standard in acc. with ISO/IEC 11 801: Category 6

Structure: two wires twisted to a pair, shielded, 4 pairs twisted with shielding

Sheath: PVC green, Ø 6.8 mm

Cores: stranded, 4 x 2 x AWG 27/7 (Ø 0.15 mm)

Service temperature: -10 °C ... +70 °C

Minimum bending radius: multiple bending 8 x Ø  
one time 4 x Ø

Max. permissible tension: 70 N



## Cable for Industrial Ethernet

### Description

### Part No.

### Technical characteristics

**Industrial Ethernet cable, 4 pairs**  
for flexible installation and fast mounting  
with the Stripping Tool



Length: 20 m  
50 m  
100 m

09 45 600 0230  
09 45 600 0240  
09 45 600 0200

Cabling standard in acc. with ISO/IEC 11 801: **Category 5**

Structure: two wires twisted to a pair, 4 pairs twisted with shielding foil

Sheath: PVC black, UV resistant, Ø 6.7 mm

Cores: stranded, 4 x 2 x AWG 26/7 (Ø 0.16 mm)

Service temperature: -45 °C ... +75 °C

Minimum bending radius: multiple bending 8 x Ø  
one time 4 x Ø

Max. permissible tension: 100 N



**Industrial Ethernet cable, 4 pairs**  
for flexible installation and fast mounting  
with the Stripping Tool



Length: 20 m  
50 m  
100 m

09 45 600 0430  
09 45 600 0440  
09 45 600 0400

Cabling standard in acc. with ISO/IEC 11 801: **Category 5**

Structure: two wires twisted to a pair, 4 pairs twisted with shielding foil

Sheath: PUR green, Ø 6.7 mm

Cores: stranded, 4 x 2 x AWG 26/7 (Ø 0.16 mm)

Service temperature: -45 °C ... +75 °C

Minimum bending radius: multiple bending 8 x Ø  
one time 4 x Ø

Max. permissible tension: 100 N



## RJ Industrial Fieldpatch IP 20

### Description

### Part No.

### Technical characteristics

#### System Cables for Industrial Ethernet, pre-assembled at both ends

for the cabling of Industrial Ethernet networks (for example in accordance with the PROFINET guideline), based on RJ 45 connectors.

Applications: control cabinets and industrial environments with low environmental stress on the connector.

Transmission properties in accordance with ISO/IEC 11 801:2002:

Class D

Mating face:

2 x RJ 45 in acc. with IEC 60603-7

Protection level:

IP 20 (when mated)

#### Pin assignment:

Signal	Function	Conductor colour	RJ 45 pin no. right	RJ 45 pin no. left
TD+	Transmission Data+	Yellow	1	1
TD-	Transmission Data-	Orange	2	2
RD+	Receiver Data+	White	3	3
RD-	Receiver Data-	Blue	6	6

#### Standard System Cable for Industrial Ethernet

Length:	1.5 m
	3.0 m
	5.0 m
	10.0 m
	20.0 m
	50.0 m
	100.0 m



09 45 751 1123
09 45 751 1125
09 45 751 1127
09 45 751 1151
09 45 751 1153
09 45 751 1156
09 45 751 1161

Cable type:

Industrial Ethernet Standard Cable, 2 x 2 x AWG 22/1, star quad, double shielding

Sheath:

PVC green, Ø 6.5 mm

Connectors:

2 x HARTING RJ Industrial® IP 20 Data with IDC termination technology

#### Stranded System Cable for Industrial Ethernet

Length:	1.5 m
	3.0 m
	5.0 m
	10.0 m
	20.0 m
	50.0 m
	100.0 m



09 45 751 0023
09 45 751 0025
09 45 751 0027
09 45 751 0051
09 45 751 0053
09 45 751 0056
09 45 751 0061

Cable type:

Industrial Ethernet Stranded Cable, 2 x 2 x AWG 22/7, star quad, double shielding

Sheath:

PVC green, Ø 6.5 mm

Connectors:

2 x HARTING RJ Industrial® IP 20 Data with IDC termination technology

#### Trailing System Cable for Industrial Ethernet

Length:	1.5 m
	3.0 m
	5.0 m
	10.0 m
	20.0 m
	50.0 m
	100.0 m



09 45 751 1164
09 45 751 1166
09 45 751 1168
09 45 751 1173
09 45 751 1175
09 45 751 1178
09 45 751 1183

Cable type:

Industrial Ethernet Trailing Cable, 2 x 2 x AWG 22/7, star quad, double shielding

Sheath:

PUR green, Ø 6.5 mm

Connectors:

2 x HARTING RJ Industrial® IP 20 Data with IDC termination technology



## RJ Industrial overmoulded IP 20

### Description

### Part No.

### Technical characteristics

#### System Cables for Industrial Ethernet, pre-assembled at both ends

for the cabling of Industrial Ethernet networks (for example in accordance with the PROFINET guideline), based on RJ 45 connectors.

Applications: control cabinets and industrial environments with low environmental stress on the connector.

Transmission properties in accordance with ISO/IEC 11 801:2002:

Class D

Mating face:

2 x RJ 45 in acc. with IEC 60603-7

Protection level:

IP 20 (when mated)

#### Electrical characteristics at 20 °C

Contact resistance:  $\leq 20 \text{ m}\Omega$

Insulation resistance:  $\geq 500 \text{ M}\Omega$

Dielectric withstanding voltage:

contact - contact 1 kV

contact - ground 1.5 kV

#### Electrical characteristics after damp heat cycles

Contact resistance:  $\leq 20 \text{ m}\Omega$

Insulation resistance:  $\geq 100 \text{ M}\Omega$

Dielectric withstanding voltage:

contact - contact 1 kV

contact - ground 1.5 kV

Standard System Cable for Industrial Ethernet overmoulded

Length: 1.5 m

09 45 771 0023

3.0 m

09 45 771 0025

5.0 m

09 45 771 0027

10.0 m

09 45 771 0051

20.0 m

09 45 771 0053

50.0 m

09 45 771 0056

100.0 m

09 45 771 0061



Cable type:

Industrial Ethernet Standard Cable, 2 x 2 x AWG 22/1, star quad, double shielding

Sheath:

PVC green,  $\varnothing 6.5 \text{ mm}$

Connectors:

2 x HARTING RJ Industrial® IP 20 Data with overmoulded housings

Stranded System Cable for Industrial Ethernet overmoulded

Length: 1.5 m

09 45 771 1123

3.0 m

09 45 771 1125

5.0 m

09 45 771 1127

10.0 m

09 45 771 1151

20.0 m

09 45 771 1153

50.0 m

09 45 771 1156

100.0 m

09 45 771 1161



Cable type:

Industrial Ethernet Stranded Cable, 2 x 2 x AWG 22/7, star quad, double shielding

Sheath:

PVC green,  $\varnothing 6.5 \text{ mm}$

Connectors:

2 x HARTING RJ Industrial® IP 20 Data with overmoulded housings

Trailing System Cable for Industrial Ethernet overmoulded

Length: 1.5 m

09 45 771 1164

3.0 m

09 45 771 1166

5.0 m

09 45 771 1168

10.0 m

09 45 771 1173

20.0 m

09 45 771 1175

50.0 m

09 45 771 1178

100.0 m

09 45 771 1183



Cable type:

Industrial Ethernet Trailing Cable, 2 x 2 x AWG 22/7, star quad, double shielding

Sheath:

PUR green,  $\varnothing 6.5 \text{ mm}$

Connectors:

2 x HARTING RJ Industrial® IP 20 Data with overmoulded housings



right entry



left entry



top entry



bottom entry

## RJ Industrial overmoulded IP 20

### Description

### Part No.

### Technical characteristics

#### System Cables for Industrial Ethernet, pre-assembled at both ends

for the cabling of Industrial Ethernet networks (for example in accordance with the PROFINET guideline), based on RJ 45 connectors.

Applications: control cabinets and industrial environments with low environmental stress on the connector.

Transmission properties in accordance with ISO/IEC 11 801:2002:

Class D

Mating face:

2 x RJ 45 in acc. with IEC 60603-7

Protection level:

IP 20 (when mated)

#### Electrical characteristics at 20 °C

Contact resistance:  $\leq 20 \text{ m}\Omega$

Insulation resistance:  $\geq 500 \text{ M}\Omega$

Dielectric withstanding voltage:

contact - contact 1 kV

contact - ground 1.5 kV

#### Electrical characteristics after damp heat cycles

Contact resistance:  $\leq 20 \text{ m}\Omega$

Insulation resistance:  $\geq 100 \text{ M}\Omega$

Dielectric withstanding voltage:

contact - contact 1 kV

contact - ground 1.5 kV

Standard System Cable for Industrial Ethernet overmoulded

Length: 1.5 m

09 45 771 4023

3.0 m

09 45 771 4025

5.0 m

09 45 771 4027

10.0 m

09 45 771 4051

20.0 m

09 45 771 4053

50.0 m

09 45 771 4056

100.0 m

09 45 771 4061



Cable type:

Industrial Ethernet Standard Cable, 2 x 2 x AWG 22/1, star quad, double shielding

Sheath:

PVC green,  $\varnothing 6.5 \text{ mm}$

Connectors:

2 x HARTING RJ Industrial® IP 20 Data with overmoulded housings, 90° angled, right entries

Stranded System Cable for Industrial Ethernet overmoulded

Length: 1.5 m

09 45 771 4123

3.0 m

09 45 771 4125

5.0 m

09 45 771 4127

10.0 m

09 45 771 4151

20.0 m

09 45 771 4153

50.0 m

09 45 771 4156

100.0 m

09 45 771 4161



Cable type:

Industrial Ethernet Stranded Cable, 2 x 2 x AWG 22/7, star quad, double shielding

Sheath:

PVC green,  $\varnothing 6.5 \text{ mm}$

Connectors:

2 x HARTING RJ Industrial® IP 20 Data with overmoulded housings, 90° angled, right entries

Trailing System Cable for Industrial Ethernet overmoulded

Length: 1.5 m

09 45 771 4164

3.0 m

09 45 771 4166

5.0 m

09 45 771 4168

10.0 m

09 45 771 4173

20.0 m

09 45 771 4175

50.0 m

09 45 771 4178

100.0 m

09 45 771 4183



Cable type:

Industrial Ethernet Trailing Cable, 2 x 2 x AWG 22/7, star quad, double shielding

Sheath:

PUR green,  $\varnothing 6.5 \text{ mm}$

Connectors:

2 x HARTING RJ Industrial® IP 20 Data with overmoulded housings, 90° angled, right entries

Overmoulded housings can be supplied with left, top or bottom entry as well.





## RJ Industrial Fieldpatch Han® PushPull S

### Description

### Part No.

### Technical characteristics

#### System Cables for Industrial Ethernet, pre-assembled at both ends

for the cabling of Industrial Ethernet networks (for example in accordance with the PROFINET guideline), based on RJ 45 connectors.

Applications: industrial environments with high environmental stress, small mounting dimensions and frequent mating cycles.

Transmission properties in accordance with ISO/IEC 11 801:2002:

Class D

Mating face:

2 x RJ 45 in acc. with IEC 60603-7

Protection level:

IP 67/65 (when mated)

#### Pin assignment:

Signal	Function	Conductor colour	RJ 45 pin no. right	RJ 45 pin no. left
TD+	Transmission Data+	Yellow	1	1
TD-	Transmission Data-	Orange	2	2
RD+	Receiver Data+	White	3	3
RD-	Receiver Data-	Blue	6	6

#### Standard System Cable for Industrial Ethernet

Length:	1.5 m
	3.0 m
	5.0 m
	10.0 m
	20.0 m
	50.0 m
	100.0 m

09 45 745 1123
09 45 745 1125
09 45 745 1127
09 45 745 1151
09 45 745 1153
09 45 745 1156
09 45 745 1161



Cable type:

Industrial Ethernet Standard Cable, 2 x 2 x AWG 22/1, star quad, double shielding

Sheath:

PVC green, Ø 6.5 mm

Connectors:

2 x Han® PushPull S with IDC termination and fast locking technology

#### Stranded System Cable for Industrial Ethernet

Length:	1.5 m
	3.0 m
	5.0 m
	10.0 m
	20.0 m
	50.0 m
	100.0 m

09 45 745 1164
09 45 745 1166
09 45 745 1168
09 45 745 1173
09 45 745 1175
09 45 745 1178
09 45 745 1183



Cable type:

Industrial Ethernet Stranded Cable, 2 x 2 x AWG 22/7, star quad, double shielding

Sheath:

PVC green, Ø 6.5 mm

Connectors:

2 x Han® PushPull S with IDC termination and fast locking technology

#### Trailing System Cable for Industrial Ethernet

Length:	1.5 m
	3.0 m
	5.0 m
	10.0 m
	20.0 m
	50.0 m
	100.0 m

09 45 745 0023
09 45 745 0025
09 45 745 0027
09 45 745 0051
09 45 745 0053
09 45 745 0056
09 45 745 0061



Cable type:

Industrial Ethernet Trailing Cable, 2 x 2 x AWG 22/7, star quad, double shielding

Sheath:

PUR green, Ø 6.5 mm

Connectors:

2 x Han® PushPull S with IDC termination and fast locking technology



## RJ Industrial Fieldpatch Han® PushPull S / IP 20

Description	Part No.	Technical characteristics																									
<p><b>System Cables for Industrial Ethernet, pre-assembled at both ends</b></p> <p>for the cabling of Industrial Ethernet networks (for example in accordance with the PROFINET guideline), based on RJ 45 connectors.</p> <p>Applications: industrial environments with high environmental stress, small mounting dimensions and frequent mating cycles.</p>		<p>Transmission properties in accordance with ISO/IEC 11 801:2002: Class D</p> <p>Mating face: 2 x RJ 45 in acc. with IEC 60603-7</p> <p>Protection level: IP 20 / IP 67/65 (when mated)</p> <p>Pin assignment:</p> <table border="1"> <thead> <tr> <th>Signal</th> <th>Function</th> <th>Conductor colour</th> <th>RJ 45 pin no. right</th> <th>RJ 45 pin no. left</th> </tr> </thead> <tbody> <tr> <td>TD+</td> <td>Transmission Data+</td> <td>Yellow</td> <td>1</td> <td>1</td> </tr> <tr> <td>TD-</td> <td>Transmission Data-</td> <td>Orange</td> <td>2</td> <td>2</td> </tr> <tr> <td>RD+</td> <td>Receiver Data+</td> <td>White</td> <td>3</td> <td>3</td> </tr> <tr> <td>RD-</td> <td>Receiver Data-</td> <td>Blue</td> <td>6</td> <td>6</td> </tr> </tbody> </table>	Signal	Function	Conductor colour	RJ 45 pin no. right	RJ 45 pin no. left	TD+	Transmission Data+	Yellow	1	1	TD-	Transmission Data-	Orange	2	2	RD+	Receiver Data+	White	3	3	RD-	Receiver Data-	Blue	6	6
Signal	Function	Conductor colour	RJ 45 pin no. right	RJ 45 pin no. left																							
TD+	Transmission Data+	Yellow	1	1																							
TD-	Transmission Data-	Orange	2	2																							
RD+	Receiver Data+	White	3	3																							
RD-	Receiver Data-	Blue	6	6																							
<p>Standard System Cable for Industrial Ethernet</p> <p>Length: 1.5 m 3.0 m 5.0 m 10.0 m 20.0 m 50.0 m 100.0 m</p>	<p>09 45 701 1123 09 45 701 1125 09 45 701 1127 09 45 701 1151 09 45 701 1153 09 45 701 1156 09 45 701 1161</p>	<p>Cable type: Industrial Ethernet Standard Cable, 2 x 2 x AWG 22/1, star quad, double shielding</p> <p>Sheath: PVC green, Ø 6.5 mm</p> <p>Connectors: 1 x Han® PushPull S with IDC termination and fast locking technology 1 x HARTING RJ Industrial® IP 20 Data with IDC termination technology</p>																									
<p>Stranded System Cable for Industrial Ethernet</p> <p>Length: 1.5 m 3.0 m 5.0 m 10.0 m 20.0 m 50.0 m 100.0 m</p>	<p>09 45 701 1164 09 45 701 1166 09 45 701 1168 09 45 701 1173 09 45 701 1175 09 45 701 1178 09 45 701 1183</p>	<p>Cable type: Industrial Ethernet Stranded Cable, 2 x 2 x AWG 22/7, star quad, double shielding</p> <p>Sheath: PVC green, Ø 6.5 mm</p> <p>Connectors: 1 x Han® PushPull S with IDC termination and fast locking technology 1 x HARTING RJ Industrial® IP 20 Data with IDC termination technology</p>																									
<p>Trailing System Cable for Industrial Ethernet</p> <p>Length: 1.5 m 3.0 m 5.0 m 10.0 m 20.0 m 50.0 m 100.0 m</p>	<p>09 45 701 0023 09 45 701 0025 09 45 701 0027 09 45 701 0051 09 45 701 0053 09 45 701 0056 09 45 701 0061</p>	<p>Cable type: Industrial Ethernet Trailing Cable, 2 x 2 x AWG 22/7, star quad, double shielding</p> <p>Sheath: PUR green, Ø 6.5 mm</p> <p>Connectors: 1 x Han® PushPull S with IDC termination and fast locking technology 1 x HARTING RJ Industrial® IP 20 Data with IDC termination technology</p>																									



## RJ Industrial Fieldpatch IP 67 Data 3A

### Description

### Part No.

### Technical characteristics

#### System Cables for Industrial Ethernet, pre-assembled at both ends

for the cabling of Industrial Ethernet networks (for example in accordance with the PROFINET guideline), based on RJ 45 connectors.

Applications: industrial environments with high environmental stress and mechanical stress.

Transmission properties in accordance with ISO/IEC 11 801:2002:

Class D

Mating face:

2 x RJ 45 in acc. with IEC 60603-7

Protection level:

IP 67/65 (when mated)

#### Pin assignment:

Signal	Function	Conductor colour	RJ 45 pin no. right	RJ 45 pin no. left
TD+	Transmission Data+	Yellow	1	1
TD-	Transmission Data-	Orange	2	2
RD+	Receiver Data+	White	3	3
RD-	Receiver Data-	Blue	6	6

#### Standard System Cable for Industrial Ethernet

Length:	1.5 m
	3.0 m
	5.0 m
	10.0 m
	20.0 m
	50.0 m
	100.0 m

09 45 715 1123
09 45 715 1125
09 45 715 1127
09 45 715 1151
09 45 715 1153
09 45 715 1156
09 45 715 1161



Cable type:

Industrial Ethernet Standard Cable, 2 x 2 x AWG 22/1, star quad, double shielding

Sheath:

PVC green, Ø 6.5 mm

Connectors:

2 x HARTING RJ Industrial® IP 67 Data 3A with IDC termination technology and zinc die-cast full metal housing

#### Stranded System Cable for Industrial Ethernet

Length:	1.5 m
	3.0 m
	5.0 m
	10.0 m
	20.0 m
	50.0 m
	100.0 m

09 45 715 1164
09 45 715 1166
09 45 715 1168
09 45 715 1173
09 45 715 1175
09 45 715 1178
09 45 715 1183



Cable type:

Industrial Ethernet Stranded Cable, 2 x 2 x AWG 22/7, star quad, double shielding

Sheath:

PVC green, Ø 6.5 mm

Connectors:

2 x HARTING RJ Industrial® IP 67 Data 3A with IDC termination technology and zinc die-cast full metal housing

#### Trailing System Cable for Industrial Ethernet

Length:	1.5 m
	3.0 m
	5.0 m
	10.0 m
	20.0 m
	50.0 m
	100.0 m

09 45 715 0023
09 45 715 0025
09 45 715 0027
09 45 715 0051
09 45 715 0053
09 45 715 0056
09 45 715 0061



Cable type:

Industrial Ethernet Trailing Cable, 2 x 2 x AWG 22/7, star quad, double shielding

Sheath:

PUR green, Ø 6.5 mm

Connectors:

2 x HARTING RJ Industrial® IP 67 Data 3A with IDC termination technology and zinc die-cast full metal housing



## RJ Industrial Fieldpatch IP 67 Hybrid

### Description

### Part No.

### Technical characteristics

#### System Cables for Industrial Ethernet, pre-assembled at both ends

for the cabling of Industrial Ethernet networks (for example in accordance with the PROFINET guideline), based on RJ 45 connectors.

Applications: industrial environments with the need for simultaneous data and energy supply and with a high environmental stress on the connector.

Transmission properties in accordance with ISO/IEC 11 801:2002:

Class D

Sheath:

FRNC green, Ø 10.3 mm

Mating face:

2 x RJ 45 in acc. with IEC 60603-7 plus 4 x power supply

Protection level:

IP 67/65 (when mated)

#### Pin assignment:

Signal	Function	Conductor colour	RJ 45 pin no. right	RJ 45 pin no. left
TD+	Transmission Data+	Yellow	1	1
TD-	Transmission Data-	Orange	2	2
RD+	Receiver Data+	White	3	3
RD-	Receiver Data-	Blue	6	6

#### Hybrid System Cable for Industrial Ethernet

Length: 1.5 m

09 45 725 1323

3.0 m

09 45 725 1325

5.0 m

09 45 725 1327

10.0 m

09 45 725 1351

20.0 m

09 45 725 1353

50.0 m

09 45 725 1356

100.0 m

09 45 725 1361



Cable type:

Industrial Ethernet Hybrid Cable, 2 x 2 x AWG 22/7 plus 4 x power supply

Connectors:

2 x HARTING RJ Industrial® IP 67 Hybrid with IDC termination technology

Category 6



RJ Industrial Fieldpatch IP 20

Description	Part No.	Technical characteristics
<p><b>System Cables for Industrial Ethernet, pre-assembled at both ends</b></p> <p>for the application neutral cabling of Industrial networks in accordance with ISO/IEC 11 801, based on RJ 45 connectors.</p> <p>Applications: control cabinets and industrial environments with low environmental stress on the connector, and applications where 4 pairs or high end Ethernet Cabling is required.</p>		<p>Transmission properties in accordance with ISO/IEC 11 801:2002:</p> <p>Class E</p> <p>Sheath: PVC green, Ø 6.8 mm</p> <p>Mating face: 2 x RJ 45 in acc. with IEC 60603-7</p> <p>Protection level: IP 20 (when mated)</p>
<p>Stranded System Cable for Industrial Ethernet</p>  <p>Length: 1.5 m</p> <p>3.0 m</p> <p>5.0 m</p> <p>10.0 m</p> <p>20.0 m</p>	<p>09 45 751 1523</p> <p>09 45 751 1525</p> <p>09 45 751 1527</p> <p>09 45 751 1551</p> <p>09 45 751 1553</p>	<p>Cable type: Industrial Ethernet Stranded Cable, Category 6, 4 x 2 x AWG 27/7, shielded twisted pair</p> <p>Connectors: 2 x HARTING RJ Industrial® IP 20 Data, 4 pairs, Category 6</p>

Industrial interfaces

Category 6

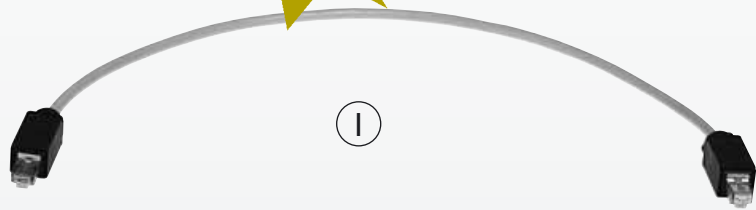

## RJ Industrial Fieldpatch Han® PushPull S

### Description

### Part No.

### Technical characteristics

#### System Cables for Industrial Ethernet, pre-assembled at both ends

for the application neutral cabling of Industrial networks in accordance with ISO/IEC 11 801, based on RJ 45 connectors.

Applications: industrial environments with high environmental stress, small mounting dimensions, frequent mating cycles and applications where 4 pairs or high end Ethernet Cabling is required.

Transmission properties in accordance with ISO/IEC 11 801:2002:

Class E

Sheath:

PVC green, Ø 6.8 mm

Mating face:

2 x RJ 45 in acc. with IEC 60603-7

#### Stranded System Cable for Industrial Ethernet



Length: 1.5 m

3.0 m

5.0 m

10.0 m

20.0 m

09 45 745 1523

09 45 745 1525

09 45 745 1527

09 45 745 1551

09 45 745 1553

Cable type: Industrial Ethernet Stranded Cable, Category 6, 4 x 2 x AWG 27/7, shielded twisted pair

Connectors: 2 x Han® PushPull S, 4 pairs, Category 6

Protection level: IP 67/65 (when mated)

#### Stranded System Cable for Industrial Ethernet



Length: 1.5 m

3.0 m

5.0 m

10.0 m

20.0 m

09 45 701 1509

09 45 701 1510

09 45 701 1511

09 45 701 1512

09 45 701 1514

Cable type: Industrial Ethernet Stranded Cable, Category 6, 4 x 2 x AWG 27/7, shielded twisted pair

Connectors: 1 x Han® PushPull S, 4 pairs, Category 6  
1 x HARTING RJ Industrial® IP 20 Data, 4 pairs, Category 6

Protection level: IP 20 / IP 67/65 (when mated)



Category 6



## RJ Industrial Fieldpatch IP 67 Data 3A

### Description

### Part No.

### Technical characteristics

#### System Cables for Industrial Ethernet, pre-assembled at both ends

for the application neutral cabling of Industrial networks in accordance with ISO/IEC 11 801, based on RJ 45 connectors.

Applications: industrial environments with high environmental stress, mechanical stress and applications where Class E Ethernet or 4 pairs cabling is required.

Transmission properties in accordance with ISO/IEC 11 801:2002:

Sheath: PVC green, Ø 6.8 mm  
 Mating face: 2 x RJ 45 in acc. with IEC 60603-7  
 Protection level: IP 67/65 (when mated)

Class E

PVC green, Ø 6.8 mm

2 x RJ 45 in acc. with IEC 60603-7

IP 67/65 (when mated)

#### Stranded System Cable for Industrial Ethernet



Length:	Part No.
1.5 m	09 45 715 1523
3.0 m	09 45 715 1525
5.0 m	09 45 715 1527
10.0 m	09 45 715 1551
20.0 m	09 45 715 1553

Cable type: Industrial Ethernet Stranded Cable, Category 6, 4 x 2 x AWG 27/7, shielded twisted pair

Connectors: 2 x HARTING RJ Industrial® IP 67 Data 3A with zinc die-cast full metal housing, 4 pairs, Category 6



## Housing with integrated patch cable

Description	Part No.	Technical characteristics
<p><b>System Cables for Industrial Ethernet, pre-assembled at both ends</b></p> <p>for the application neutral cabling of Industrial networks in accordance with ISO/IEC 11 801, based on RJ 45 connectors.</p>		<p>Transmission properties in accordance with ISO/IEC 11 801:2002: Class D</p> <p>Sheath: PVC green, Ø 6.8 mm</p> <p>Mating face: RJ 45 in acc. with IEC 60603-7</p>
<p>Han® PushPull S housing / IP 20</p> <p>ⓘ</p> <p>Length: 1.5 m 3.0 m</p>	<p>09 45 751 0123 09 45 751 0125</p>	<p>Housing: Han® PushPull S</p> <p>Connector: HARTING RJ Industrial® IP 20 Data, 4 pairs</p>
<p>IP 67 Data 3A housing / IP 20</p> <p>Length: 1.5 m 3.0 m</p>	<p>09 45 715 0123 09 45 715 0125</p>	<p>Housing: IP 67 Data 3A metal, grey</p> <p>Connector: HARTING RJ Industrial® IP 20 Data, 4 pairs</p>

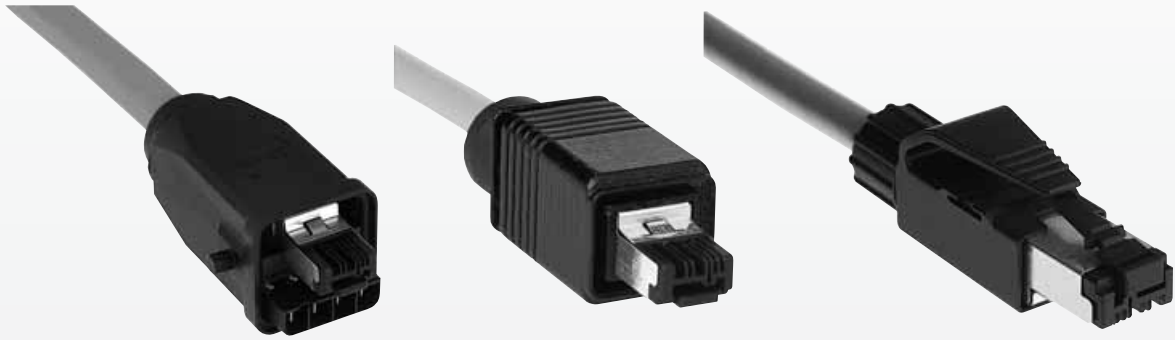

## HARTING RJ Industrial® Ethernet connector family

The modular HARTING RJ Industrial® family of connectors is based on the standard RJ 45 connector pattern, and is specifically developed for use in harsh industrial environments. It points the way forward in connecting Ethernet devices in industrial applications. In many circumstances it is necessary for connectors to be assembled on site, regardless of whether they are being used for power or communication. HARTING is making consistent use of their *HARAX*® rapid termination technology, which has been proven in many industrial applications. With *HARAX*® the user can terminate the cable at the connectors without the need for special tools. The design of the HARTING RJ Industrial® family of connectors allows for quick and easy termination and connection to Ethernet devices in either data only or hybrid networks.

HARTING RJ Industrial® is the first RJ 45 connector in the world that allows robust Ethernet cables with a solid and stranded AWG 22 cross section to be connected using IDC technology. The heart of each of these connectors is the RJ 45 data module with fast termination technology. This functions without needing to prestrip insulation from the cores and without special tools, creating a gas-tight connection, which is secure against vibration. The data module has four *HARAX*® fast termination contacts. These make reliable contact with stranded, industry-standard Category 5 cables with dimensions from AWG 22 to 24, and solid cables with conductor cross-sections from AWG 22 to 23.

HARTING has developed a complete family of connectors around this innovative data module, meeting all the needs of industrial environments. Solutions for IP 20 and IP 67 protection levels, standard, Push Pull and latching clip-locks are available.



Data and hybrid cables can be used. The user can fit stranded cores with a cross section of 1.5 mm<sup>2</sup> for the IDC power contacts on the Hybrid version, and these can be loaded with up to 16 A.

At the device end, panel feed throughs or couplings integrated directly into the device can be accommodated. Consistent application of SMD components for both data and power at the device end keeps manufacturing costs low, and permits high packing density within the assembly.

## Field assembly of Industrial Ethernet connectors

The facility of on-site assembly was given high priority in the development of the new HARTING RJ Industrial® family of connectors. As a result, the connector is not just faster to terminate, but is also easier to handle due to the reduced number of individual parts.

All of the HARTING RJ Industrial® range connectors can be re-terminated up to ten times. An electrician can carry out assembly of the IP 20 Data version on site in less than one minute, while the IP 67 Hybrid version requires less than three minutes. Dismantling is just as quick. New personnel can also learn the individual steps involved very quickly and carry them out reliably.

Another advantage of the quick-connection technology is provided by the industrial-quality shielding of the data module in the connector. Termination of the shield which in the past has been achieved by crimping is no longer necessary. In the RJ Industrial connection technology, a pair of shielding plates are simply pushed over the data module, and pressed together with an audible "click". With this, complete, 360 degree connection of the shield and the sheath is achieved.

Various special tools for handling the RJ 45 data module and the power leads are unnecessary. HARTING supplies all the necessary components in a complete set.

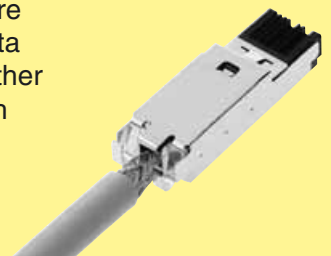





**Standardised connectors**

From the very beginning, HARTING saw it as its task to set a broad standard for Ethernet in industrial environments through a uniform connector solution. Through its involvement in the PNO (PROFIBUS Nutzerorganisation e.V.), the IAONA (Industrial Automation Open Networking Alliance e.V.), the

DKE (Deutsche Kommission Elektrotechnik Elektronik Informationstechnik) and also with the IEC (International Electrotechnical Committee), HARTING contributed to advancing the specification of industry-standard Ethernet connectors.

In addition to this an international standardisation process was initiated, because the HARTING approach is not a proprietary system, but an open solution for Industrial Ethernet interfaces.

		Device side			
		IP 20 Data Standard RJ 45 jack	Han® PushPull S	IP 67 Hybrid	IP 67 Data 3A
Cable side	IP 20 Data 	✓	✓	✓	✓
	Han® PushPull S 		✓		
	IP 67 Hybrid 			✓	
	IP 67 Data 3A 			✓	✓

Mating compatibility of the HARTING RJ Industrial® family

**Assembly operations**  
**HARTING RJ Industrial® IP 20 Data**

Only a few steps are necessary to quickly and reliably connect an Industrial Ethernet cable to a HARTING RJ Industrial® connector with IDC connection technology.

- ① Push the housing complete with cable gland over the outer insulation of the cable
- ② Strip the correct length of outer insulation and shielding braid
- ③ Prepare the cores to match the splicing piece in accordance with the colour code
- ④ Insert the cores into the splicing piece to the required depth
- ⑤ Place the splicing piece on the RJ 45 data module and engage it

- ⑥ Place the data module and the splicing piece into the supplied IDC assembly tool
- ⑦ Press the data module and the IDC assembly tool together, to make the insulation displacement contact
- ⑧ Remove the assembled data module from the IDC assembly tool
- ⑨ Put on the upper shield plate, and push it over the cable shield
- ⑩ Put the lower shield plate in place, and latch it to the upper shield plate with an audible click
- ⑪ Push the housing over the assembled data module, latching it into place with an audible click
- ⑫ Tighten the cable gland

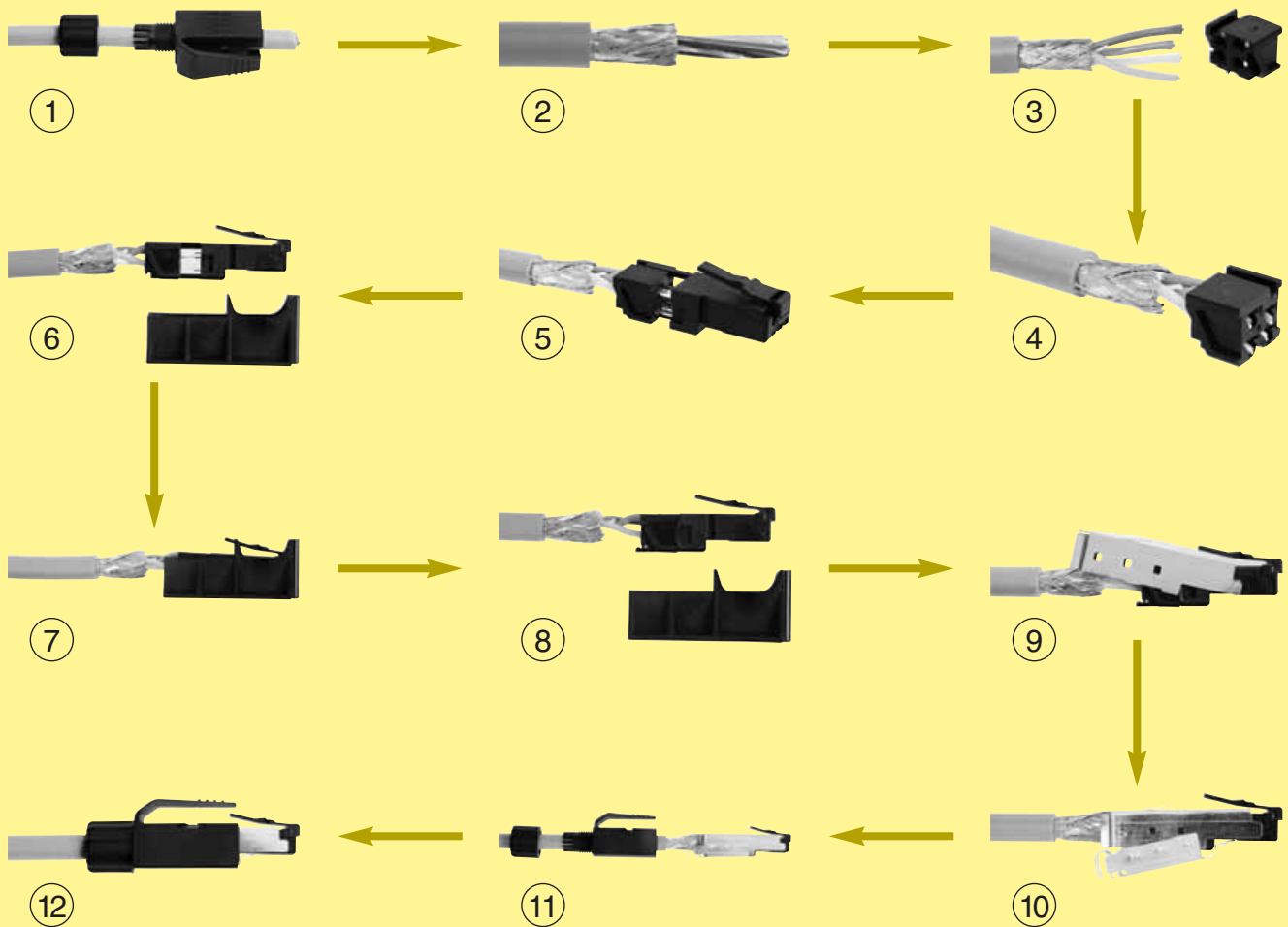

Industrial interfaces

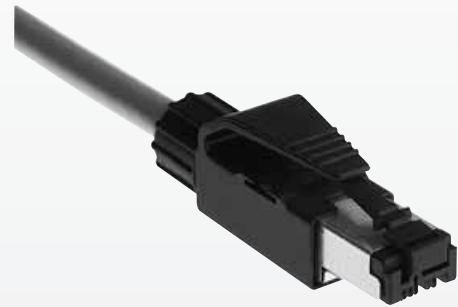

IP 20 Data connectors

Identification

Part No.

Drawing

Dimensions in mm

Connector set

incl. housing, cable gland and instruction manual

09 45 151 1100

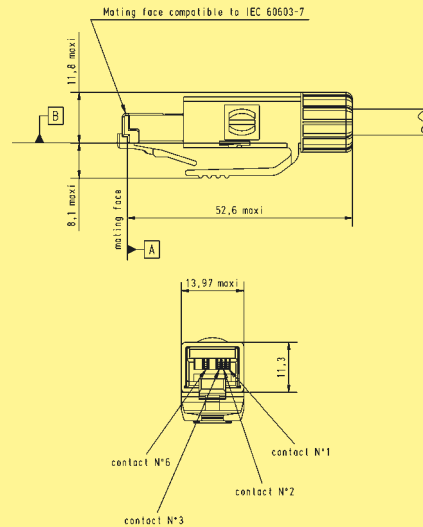

Technical characteristics

Transmission properties in accordance with Category 5 ISO/IEC 11 801:2002 and EN 50173-1

- Protection level: IP 20
- Mating interface: RJ 45 in accordance with IEC 60603-7
- Wire gauge data<sup>1)</sup>: AWG 22 - 24 stranded  
AWG 22 - 23 solid
- Temperature range: -40 °C ... +70 °C
- Cable sheath diameter: 6.5 mm - 6.9 mm
- Mating cycles: min. 750
- Housing material: Polycarbonate, black  
UL 94-V0



UL recognised, E102079

General information

The IP 20 Data connector complies with the requirements of industrial applications. This RJ 45 Ethernet connector can be connected to AWG-22 cables with IDC technology and is designed with a standard pitch of just 14 mm, which guarantees maximum packing density in the application. An additional latching clip on the housing makes its significantly easier to unlock the connector.

This connector can be assembled on site, permitting Industrial Ethernet installation cable to be connected directly to IP 20 devices located inside a control cabinet. A special panel feed through to provide the transition between protection level IP 67 and IP 20 is therefore not necessary. This lessens the installation work required from the customer, while the reduced number of contact points offers increased reliability.

<sup>1)</sup> Details see technical data sheet





Han® PushPull S connectors

Identification

Part No.

Drawing

Dimensions in mm

Connector set

incl. housing, cable gland and instruction manual

09 45 145 1100

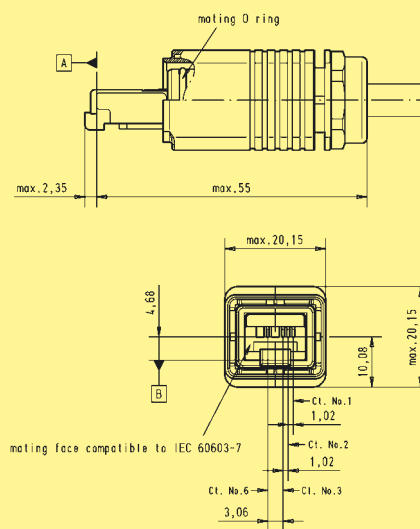

Protection cover for connectors with cord, IP 67/65

09 45 845 0001

Technical characteristics

Transmission properties in accordance with Category 5 ISO/IEC 11 801:2002 and EN 50173-1

Protection level:	IP 67/65
Locking mechanism:	Push Pull acc. to ISO/IEC 24 702 and IEC 61 076-3-106, variant 4
Mating interface:	RJ 45 in accordance with IEC 60603-7
Wire gauge data <sup>1)</sup> :	AWG 22 - 24 stranded AWG 22 - 23 solid
Temperature range:	-40 °C ... +70 °C
Cable sheath diameter:	6.5 mm - 8.6 mm
Mating cycles:	min. 750
Housing material:	Polyamide, black Polycarbonate, black UV resistant UL 94-V0
	UL recognised, E102079

General information

The IP 67 Data version in a Push Pull housing is fitted with innovative housing locking technology. The housing of the connector is locked tightly to the hood by means of a locking sleeve that surrounds it. The connector can be locked and unlocked using one hand and only minimal force. In spite of its high degree of protection, the housing is very compact, and is ideally suited for compact industrial applications.

The Han® PushPull S is thus the smallest IP 67/65 Industrial Ethernet connector based on RJ 45 with IDC connection technology in the world.





Han® PushPull S panel feed through

Identification	Part No.	Drawing	Dimensions in mm
<p><b>Panel feed through set</b> incl. housing and instruction manual, fixing holes M2.5</p> <p>(I)</p>	09 45 245 1102		
<p><b>Separate housing</b> incl. flat sealing for direct device integration, fixing holes M2.5</p> <p>(II)</p> <p>with clip</p> <p>without clip</p>	09 45 545 0021 09 45 545 0023		
<p><b>RJ 45 panel feed through</b> for direct device integration, Category 5, shielded</p> <p>(III)</p> <p>SMD through hole</p>	09 45 551 1100 09 45 551 1102		
<p><b>Protection cover for panel feed through</b> with cord, IP 67/65, fixing rings for M2.5</p> <p>(I)</p>	09 45 845 0004		
<p><b>IP 40 rubber protection</b> against pollution during transport</p> <p>(I)</p>	09 45 845 0003		

Industrial interfaces

Technical characteristics and general information see page 11.38



Han® PushPull S panel feed through

## Technical characteristics

Transmission properties in accordance with Category 5 ISO/IEC 11 801:2002 and EN 50173-1

Protection level:	IP 67/65
Locking mechanism:	Push Pull acc. to ISO/IEC 24 702 and IEC 61 076-3-106, variant 4
Mating interface internal and external:	RJ 45 jack in accordance with IEC 60603-7
Temperature range:	-40 °C ... +70 °C
Panel cut out:	21 x 27 mm
Fixing hole:	M2.5
Mating cycles:	min. 750
Housing material:	Polycarbonate, black UV resistant UL 94-V0
Material RJ 45 panel feed through:	Metal
	UL recognised, E102079

## General information

The IP 67 Data version in a Push Pull housing is fitted with innovative housing locking technology. The housing of the connector is locked securely to the hood by means of a surrounding locking sleeve. In spite of the high degree of protection, the panel feed through is very compact, having a space requirement of just 21 x 27 mm, the same space as for a M12 connector.

The Han® PushPull S panel feed through is compatible with RJ 45 connectors, which means that standard patch cables for service and test purposes can also be used here.

The data lines are connected at the rear via an RJ 45 jack meeting IP 20.

Optional the Push Pull interface can be integrated in the device directly, thus preventing the use of rear side data lines.

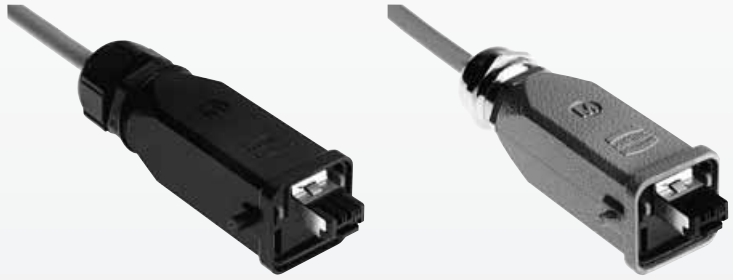

IP 67 Data 3A connectors

Identification	Part No.	Drawing	Dimensions in mm
----------------	----------	---------	------------------

Connector set

incl. housing, cable gland and instruction manual

Plastic version	straight	09 45 125 1100
	angled	09 45 125 1104
Standard metal version	straight	09 45 115 1100
	angled	09 45 115 1104
Metal version M	straight	09 45 115 1102
	angled	09 45 115 1106
Coding pin set		09 45 820 0000

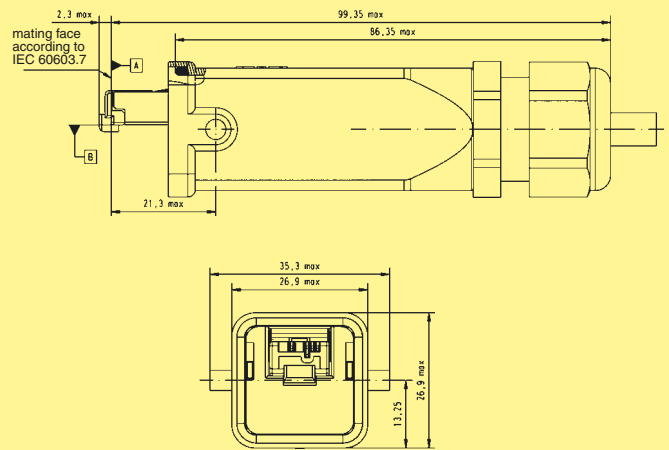

Dimensions valid for the straight plastic version

Protection cover for connectors with cord, IP 67/65

Plastic version, grey	09 20 003 5442
Standard metal version, grey	09 20 003 5422
Metal version M, black	09 37 003 5402

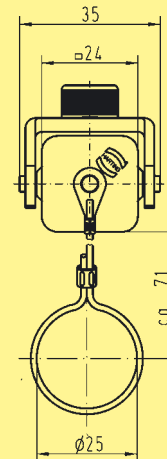

Dimensions valid for the plastic version



IP 67 Data 3A connectors

### Technical characteristics

Transmission properties in accordance with Category 5 ISO/IEC 11 801:2002 and EN 50173-1

Protection level:	IP 67/65
Mating interface:	RJ 45 in accordance with IEC 60603-7
Wire gauge data <sup>1)</sup> :	AWG 22 - 24 stranded AWG 22 - 23 solid
Temperature range:	-40 °C ... +70 °C
Cable sheath diameter:	6.0 mm - 9.0 mm
Mating cycles:	min. 500
Plastic housing material <sup>2)</sup> :	Polycarbonate, black UL 94-V0
Standard metal housing material <sup>2)</sup> :	Zinc die cast, grey
Metal housing M material <sup>2)</sup> :	Zinc die cast, alodined, powder coating, black
	UL recognised, E102079

### General information

The IP 67 Data version of the RJ Industrial is based on the RJ 45 Data module, integrated into a standard Han<sup>®</sup> 3A industry housing that can be used for most industrial applications. The housing is available in plastic or metal, and offers protection level IP 67/65.

RJ Industrial is available in Han<sup>®</sup> M housings for higher environmental stress as well.

Implementing a uniform pattern for all the connectors based on the Han<sup>®</sup> 3A contour for data and hybrid solutions means that all versions are plug-compatible for data signals. Optional coding prevents incorrect mating up to four different connectors.

<sup>1)</sup> Details see technical data sheet  
<sup>2)</sup> Details see catalogue "Industrial Connectors Han<sup>®</sup>"



IP 67 Data 3A panel feed through

Identification	Part No.	Drawing	Dimensions in mm
----------------	----------	---------	------------------

<b>Panel feed through set</b> incl. housing and instruction manual		
Plastic version	straight	09 45 225 1100
	angled	09 45 225 1108
Standard metal version	straight	09 45 215 1100
	angled	09 45 215 1108
Standard metal version with self-closing protective cap	straight	09 45 215 1103
Metal version M	straight	09 45 215 1102
	angled	09 45 215 1109
Coding pin set		09 45 820 0000

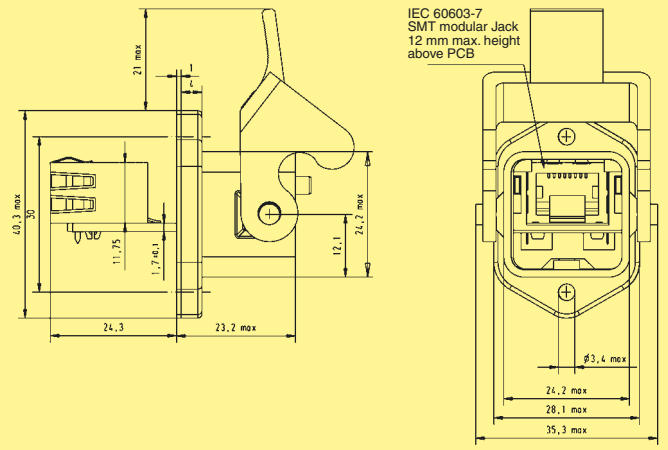

Dimensions valid for the straight plastic version

<b>Gender changer</b> incl. installation frame		
Plastic version		09 45 225 1107
Standard metal version		09 45 215 1107
Metal version M		09 45 215 1110
Coding pin set		09 45 820 0000

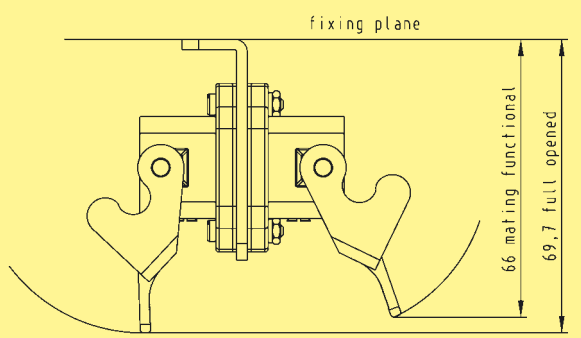

Dimensions valid for the plastic version

<b>Protection cover for panel feed through</b> IP 67/65		
Plastic version, black		09 20 003 5449
Standard metal version, grey		09 20 003 5425
Metal version M, black		09 37 003 5406

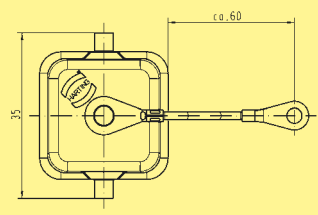

Dimensions valid for the plastic version

Industrial interfaces





IP 67 Data 3A panel feed through

## Technical characteristics

Transmission properties in accordance with Category 5 ISO/IEC 11 801:2002 and EN 50173-1

Protection level:	IP 67/65
Mating interface internal and external:	RJ 45 jack in accordance with IEC 60603-7
Panel cut out:	22 x 22 mm
Temperature range:	-40 °C ... +70 °C
Mating cycles:	min. 500
Plastic housing material <sup>1)</sup> :	Polycarbonate, black UL 94-V0
Standard metal housing material <sup>1)</sup> :	Zinc die cast, grey
Metal housing M material <sup>1)</sup> :	Zinc die cast, alodined, powder coating, black
	UL recognised, E102079

## General information

The IP 67 panel feed through data version of the RJ Industrial is based on an RJ 45 jack, integrated into a Han® 3A housing that can be used for most industrial applications. The housing is available in plastic or metal, and offers protection level IP 67/65.

RJ Industrial is available in Han® M housings for higher environmental stress as well.

Implementing a uniform plug pattern for all the connectors based on the 3A contour for data and hybrid solutions means that all versions are plug-compatible for data signals. Optional coding prevents incorrect mating up to four different connectors. The panel feed through is compatible with RJ 45 connectors, which means that standard patch cables for service and test purposes can be used. The data lines are connected at the rear via an RJ 45 jack meeting IP 20.



IP 67 Hybrid connectors

Identification	Part No.	Drawing	Dimensions in mm
<b>Connector set</b> incl. housing, cable gland and instruction manual	09 45 125 1300		
<b>Protection cover for connectors</b> with cord, IP 67/65	09 20 003 5442		

Technical characteristics

Transmission properties in accordance with Category 5 ISO/IEC 11 801:2002 and EN 50173-1

Protection level:	IP 67/65
Mating interface:	RJ 45 in accordance with IEC 60603-7 plus 4 x power supply
Wire gauge data:	AWG 22 - 24 stranded AWG 22 - 23 solid
Wire gauge power supply:	1.5 mm <sup>2</sup> stranded
Working voltage power supply:	48 V
Working current power supply:	see derating curve
Temperature range:	-40 °C ... +70 °C
Cable sheath diameter:	10 mm - 11 mm
Mating cycles:	min. 500
Housing material:	Polycarbonate, black UL 94-V0 UL recognised, E102079

General information

With the RJ Industrial Hybrid connector, HARTING has developed an interface solution that integrates the data lines and the power supply into one connector for hybrid Ethernet networks. The connector's geometry nevertheless maintains a clear separation between the data and the power contacts. This brings a significant reduction in the costs of installation and of field devices suitable for industrial application with hybrid cabling.

The four power contacts of the hybrid module have also been designed with *HARAX*<sup>®</sup> rapid termination technology, allowing stranded cables of up to 1.5 mm<sup>2</sup> to be connected.

Derating curve "Power contacts"

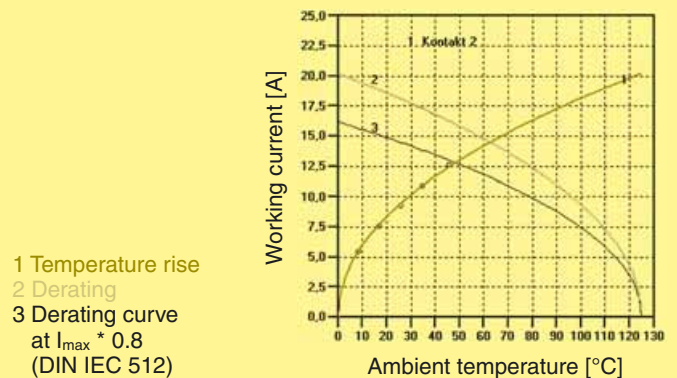



IP 67 Hybrid panel feed through

Identification	Part No.	Drawing	Dimensions in mm
<p><b>Panel feed through set</b> incl. housing and instruction manual</p> <p>Coding pin set</p> <p>(I)</p>	<p>09 45 225 1300</p> <p>09 45 820 0000</p>		
<p><b>Separate housing</b> incl. flat sealing for direct device integration</p> <p>Coding pin set</p> <p>(II)</p>	<p>09 45 525 0020</p> <p>09 45 820 0000</p>		
<p><b>Power module with 4 contacts</b> for direct device integration</p> <p>(III)</p>	<p>09 45 525 0040</p>		
<p><b>RJ 45 panel feed through</b> for direct device integration</p> <p>SMD</p>	<p>09 45 551 1100</p>		
<p><b>Protection cover</b> for panel feed through IP 67/65</p>	<p>09 20 003 5449</p>		

Industrial interfaces



## IP 67 Hybrid panel feed through

### Technical characteristics

Transmission properties in accordance with Category 5 ISO/IEC 11 801:2002 and EN 50173-1

Protection level: IP 67/65

Mating interface external: RJ 45 jack in accordance with IEC 60603-7 plus 4 x power supply

Mating interface internal: RJ 45 jack in accordance with IEC 60603-7 plus 4 x power supply with cage clamp 1.5 mm<sup>2</sup>

Working voltage power supply: 48 V

Working current power supply: see derating curve on page 03.13

Panel cut out: 22 x 22 mm

Temperature range: -40 °C ... +70 °C

Mating cycles: min. 500

Housing material: Polycarbonate, black  
UL 94-V0

Material RJ 45 panel feed through: Metal



UL recognised, E102079

### General information

With the RJ Industrial Hybrid connector, HARTING has developed an interface solution that integrates the data lines and the power supply into one connector for hybrid Ethernet networks. The connector's geometry nevertheless maintains a clear separation between the data and the power contacts. This brings a significant reduction in the costs of installation and of field devices suitable for industrial application with hybrid cabling.

The panel feed through is compatible with RJ 45 connectors, which means that the standard patch cables for service and test purposes can be used. The data lines are connected at the rear via an RJ 45 jack, while the power lines use a cage clamp terminal.

Optional the hybrid interface can be integrated in the device directly, thus preventing the use of rear side data lines.

### HARTING RJ Industrial® 4 pair

The HARTING RJ Industrial® Gigalink more than meets the tough requirements of Category 6 according to TIA/EIA 568 B.2-1:2002-06, EN 50173-1:2002 and ISO/IEC 11801:2002-09.

The integrated cable management system with simultaneous wiring radically reduces installation times in comparison with existing systems. The cable manager, which is colour-coded, supports the simultaneous insertion of the cable strands, so avoiding the time-consuming manual placement of the individual conductors.

The RJ Industrial includes an integrated cable adjustment system, such that a high quality connection is maintained in tough industrial environments over long periods, even under conditions of heavy vibration. This ensures that the

shielded twisted cores are reliably guided to their contacts within the connector. Without this innovation it would be possible for the shielding braid of the individual conductors to separate, resulting in a long-term deterioration in the crosstalk characteristic of the connector and therefore of the entire transmission line. The HARTING RJ Industrial® also exceeds the clearance and creepage requirements for industrial environments.

#### Connector family

Because of the innovative platform strategy implemented in the RJ Industrial Gigalink data module, all the other products in the RJ Industrial product family can also be used for Gigabit Ethernet.

This makes Gigabit Ethernet with Real CAT 6 also possible with IP 67 protection.

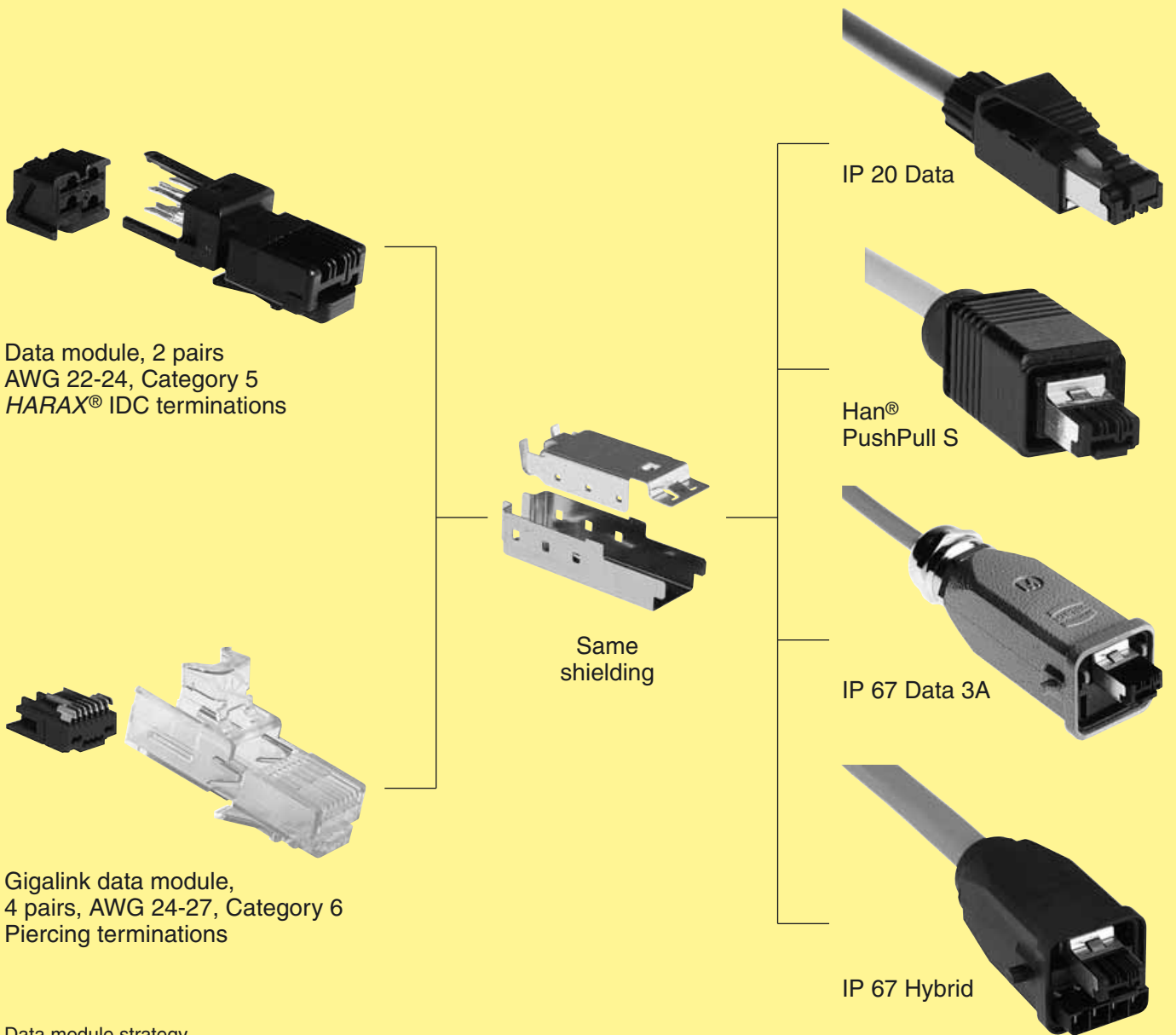

Industrial interfaces



The used CAT 6 data module adapter fits into the shielding plates of the 4 core data module with quick-connection technology. For this reason an existing 100 Mbit Fast Ethernet transmission line with HARTING RJ Industrial® connectors can easily be converted into a 1000 Mbit Gigabit Ethernet transmission line, without having to modify the connector's interface. This makes the HARTING RJ Industrial® connector family as future-proof as possible.

### Minimising cross-connection through wire management

There is no difference under Gigabit Ethernet between uplink and downlink ports. Every network device automatically recognises whether the device to which it is connected is a network card or a switch. There is therefore no need for cross-connected and through-connected cables found under 100 Mbit Fast Ethernet, where this functionality is not available.

The symmetrical structure of a 1:1 through-wired patch cable results in crossing of the wire pairs 2 and 4. This has a negative effect on the near-end crosstalk of the transmission route. For performance reasons, a symmetrical crossing of the pairs must be realized as near as possible to the connector. This is achieved by the colour-coded wire managers, which leads the conductor pairs in a defined way to the connection points on the RJ 45 jack (see figure "Wire manager"). Crossing the cross-connection in the cable manager instead of in the cable itself, so contributing to the high performance of the transmission route.

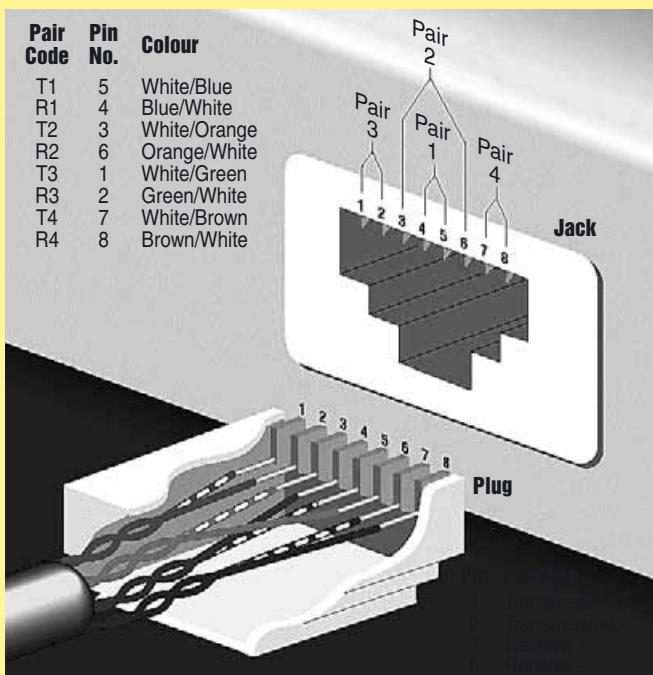

Connection of core pairs

### Wiring the data module

For historical reasons, TIA/EIA 568:2002 has two ways to connect the conductors at the connector. These describe which individual colour-coded conductors are to be brought to which contact in the connector.

- EIA/TIA 568:2002 A: This is the recommended connection variant in the EIA/TIA standard.
- EIA/TIA 568:2002 B: This connection variant matches the older AT&T 258 A colour code, which is still the most widely used wiring scheme.

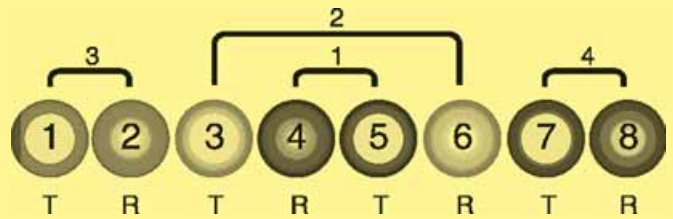

Connection in acc. with TIA/EIA 568A

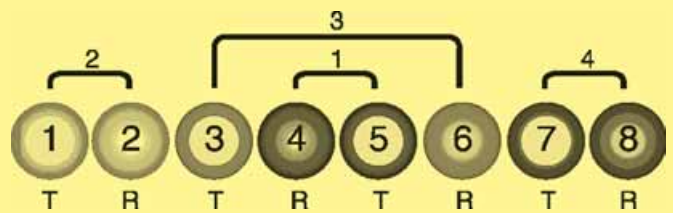

Connection in acc. with TIA/EIA 568B

The RJ 45 jack must be connected according to the appropriate scheme, depending on the application. For Gigabit Ethernet the connection is only to be made at the RJ 45 jack, not at the plug, since the conductor pairs in the patch leads are symmetrically routed due to the 1:1 auto-crossing.

The usage of different wire managers in a patch cord guarantees a symmetrical crossing of the wire pairs inside the connector. Thereby the Category 6 data transmission performance is assured.

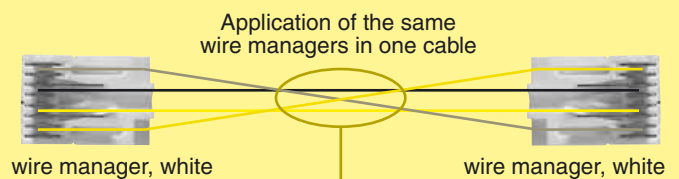
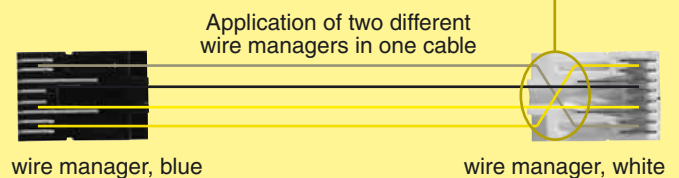

Crossover of the wire pairs leads to a degradation of the data transmission characteristics. The Category 6 performance can possibly not be achieved.

Wire manager



Category 6



IP 20 Data connectors, 4 pairs

Identification	Part No.	Drawing	Dimensions in mm
<b>Connector set</b> incl. housing, cable gland and instruction manual			
cable manager white <sup>2)</sup>	09 45 151 1500		
cable manager blue <sup>2)</sup>	09 45 151 1510		

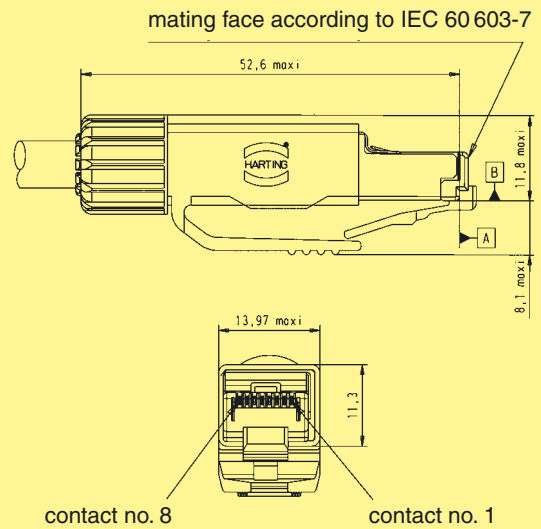

**Technical characteristics**

Transmission properties in accordance with Category 6 ISO/IEC 11 801:2002 and EN 50173-1

Protection level:	IP 20
Mating interface:	RJ 45 in accordance with IEC 60603-7
Wire gauge data <sup>1)</sup> :	AWG 24-27 stranded
Temperature range:	-40 °C ... +70 °C
Cable sheath diameter:	6.5 mm - 6.9 mm
Mating cycles:	min. 750
Housing material:	Polyamide, black UL 94-V0
	UL recognised, E102079

**General information**

The IP 20 data connector is an industrial type of RJ 45 connector for 4 pair and Gigabit Ethernet applications, to which flexible cables with AWG 26 may be connected.

For Category 6 patch cords it is recommended to use 1 connector with a white wire manager and 1 with a blue wire manager, in order to optimise the crosstalk between different signal pairs.

With a standard pitch of only 14 mm, maximum packing density in application is guaranteed.

Industrial interfaces

<sup>1)</sup> Details see technical data sheet  
<sup>2)</sup> Details see page 11.47



Han® PushPull S connectors, 4 pairs

Identification	Part No.	Drawing	Dimensions in mm
<b>Connector set</b> incl. housing, cable gland and instruction manual  cable manager white <sup>2)</sup>  cable manager blue <sup>2)</sup>	  09 45 145 1500  09 45 145 1510	mating face according to IEC 60 603-7  	
<b>Protection cover for connectors</b> with cord, IP 67/65	09 45 845 0001		

Technical characteristics

Transmission properties in accordance with Category 6 ISO/IEC 11 801:2002 and EN 50173-1

Protection level:	IP 67/65
Locking mechanism:	Push Pull acc. to ISO/IEC 24 702 and IEC 61 076-3-106, variant 4
Mating interface:	RJ 45 in accordance with IEC 60603-7
Wire gauge data <sup>1)</sup> :	AWG 24-27 stranded
Temperature range:	-40 °C ... +70 °C
Cable sheath diameter:	6.5 mm - 8.6 mm
Mating cycles:	min. 750
Housing material:	Polyamide, black Polycarbonate, black UV resistant UL 94-V0
	UL recognised, E102079

General information

The IP 67 data version in Push Pull housing is fitted with innovative housing locking technology. The housing of the connector is locked tightly to the coupling by means of a surrounding locking sleeve. The connector can be locked and unlocked using one hand and only a little force. In spite of its high degree of protection, the housing is very compact, and is ideally suited for compact industrial applications.

The Han® PushPull S Category 6 is ideally suited to compact industrial applications that require 4 pair or Gigabit Ethernet wiring.

For Category 6 patch cords it is recommended to use 1 connector with a white wire manager and 1 with a blue wire manager, in order to optimise the crosstalk between different signal pairs.



<sup>1)</sup> Details see technical data sheet  
<sup>2)</sup> Details see page 11.47



IP 67 Data 3A connectors, 4 pairs

Identification	Part No.	Drawing	Dimensions in mm
----------------	----------	---------	------------------

**Connector set**

incl. housing, cable gland and instruction manual

Plastic version      cable manager white<sup>1)</sup>      09 45 125 1500  
    cable manager blue<sup>1)</sup>      09 45 125 1510

Standard metal version  
    cable manager white<sup>1)</sup>      09 45 115 1500  
    cable manager blue<sup>1)</sup>      09 45 115 1510

Metal version M      cable manager white<sup>1)</sup>      09 45 115 1502  
    cable manager blue<sup>1)</sup>      09 45 115 1512

Coding pin set      09 45 820 0000

mating face according to IEC 60 603-7

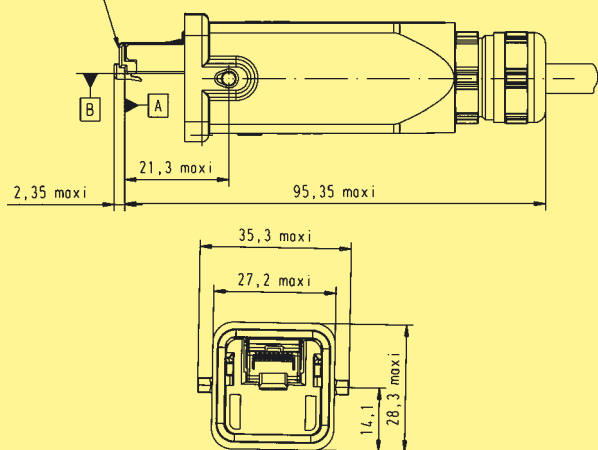

Dimensions valid for the standard metal version

**Protection cover for connectors**

with cord, IP 67/65

Plastic version, grey      09 20 003 5442

Standard metal version , grey      09 20 003 5422

Metal version M, black      09 37 003 5402

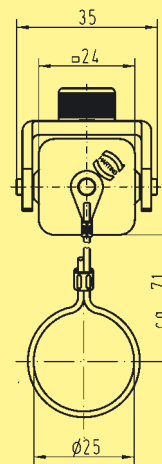

Dimensions valid for the plastic version

<sup>1)</sup> Details see page 11.47  
 Technical characteristics and general information see page 11.51



IP 67 Data 3A connectors, 4 pairs

### Technical characteristics

Transmission properties in accordance with Category 6 ISO/IEC 11 801:2002 and EN 50173-1

Protection level:	IP 67/65
Mating interface:	RJ 45 in accordance with IEC 60603-7
Wire gauge data <sup>1)</sup> :	AWG 24-27 stranded
Temperature range:	-40 °C ... +70 °C
Cable sheath diameter:	6.5 mm - 6.9 mm
Mating cycles:	min. 500
Plastic housing material <sup>2)</sup> :	Polycarbonate, black UL 94-V0
Standard metal housing material <sup>2)</sup> :	Zinc die cast, grey
Metal housing M material <sup>2)</sup> :	Zinc die cast, alodined, powder coating, black
	UL recognised, E102079

### General information

The IP 67 Data version of the RJ Industrial is based on the RJ 45 Category 6 Data module, integrated into a standard Han<sup>®</sup> 3A industry housing that can be used in any industrial application. The housing is practically available in plastic or metal, and offers protection class IP 67/65.

RJ Industrial is available in Han<sup>®</sup> M housings for higher environmental stress as well.



Implementing a uniform connector pattern for all the connectors based on the 3A contour for data and hybrid solutions means that all versions are plug-compatible for data signals. Use of optional coding prevents up to four connectors being incorrectly mated.

The HARTING RJ Industrial<sup>®</sup> Data 3A Category 6 is ideally suited to harsh industrial applications that require 4 pair or Gigabit Ethernet wiring.

For Category 6 patch cords it is recommended to use 1 connector with a white wire manager and 1 with a blue wire manager, in order to optimise the crosstalk between different signal pairs.

<sup>1)</sup> Details see technical data sheet

<sup>2)</sup> Details see catalogue "Industrial Connectors Han<sup>®</sup>"

Identification	Wire gauge (mm <sup>2</sup> )	Part No.	
<p><b>HARTING RJ Industrial® Gigalink Assembly Tool</b> for 4 pairs HARTING RJ Industrial® Gigalink connectors</p>		<p>09 45 800 0500</p>	 <p>With the RJ Industrial Gigalink Assembly Tool 4 pair connectors can be fast, easily and reliably connected to flexible cables.</p>
<p><b>HARTING RJ Industrial® Stripping Tool</b> Stripping Tool for 2 pairs PROFINET cables incl. blade cassette</p>		<p>09 45 800 0000</p>	
<p><b>Blade cassette</b></p>		<p>09 45 800 0001</p>	<p>The RJ Industrial Stripping Tool allows the insulation to be removed from suitable 2 pair and 4 pair cables for fast mounting with diameters between 2.5 - 8 mm quickly and easily. The tool is pre-set for a cable diameter of 6.5 mm. It allows the cable sheath and screening braid to be stripped consistently and simultaneously.</p>



HARTING offers with the Han® PushPull S Power connector an universal solution for the power supply in compact and robust applications. It is in its element wherever small dimensions are combined with a high protection class.

The connector is available in a 4 pole 48 V and a 2 pole 250 V version. The newly designed power contacts can carry up to 12 resp. 16 A each (see deratings). In spite of this high current carrying capacity the connector gets by with minimal dimensions and fulfils the industrial requirements for clearances and creepage distances at the same time.

Additionally the Han® PushPull S Power connector offers the protection class of IP 67 and 65. Beside numerous industrial use cases it is thereby suited for diverse applications in the fields of transportation and telecommunication.

The cable side of the Han® PushPull S Power is terminated with crimping technology. For the receptacle several solutions with different termination technologies are offered.

The innovative locking mechanism of the connector enables an easy plugging and pulling with just one hand. The mechanism is based on the same housing which is already established for the HARTING RJ Industrial® product family.

### Benefits

- Minimum space requirements in spite of high current carrying capacity
- Very compact housing in a high protection class
- Innovative Push Pull locking mechanism
- Protection against contact on plug AND receptacle side enables an easy and safe installation
- For low voltage (48 V) and for power supply (250 V) available
- Codeable without losing contacts
- Different termination technologies for individual device integration

### Typical application areas

- Factory and building automation
- Industrial electronics
- Telecommunication und wireless networks
- Transportation
- Industrial monitoring and camera systems
- Lighting and display technology
- Access control systems

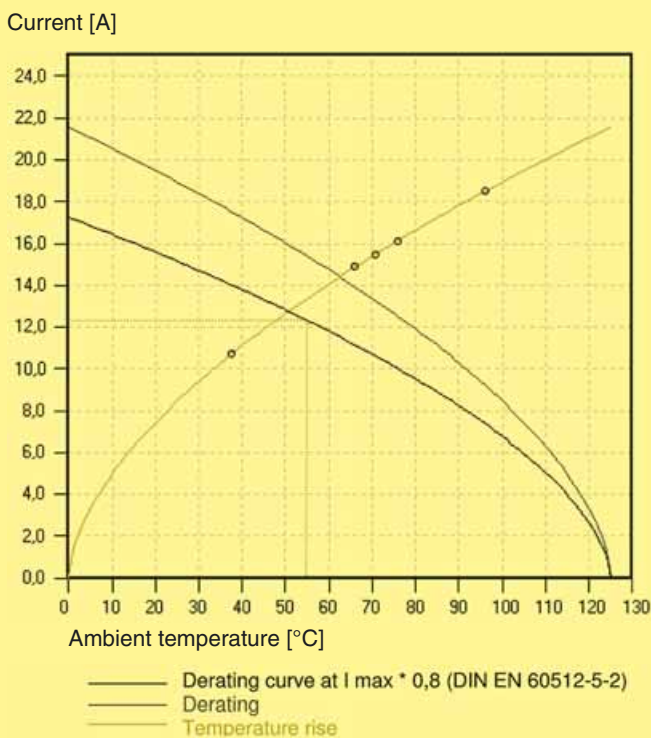

Derating diagram "low voltage, 48 V"; 4 contacts loaded

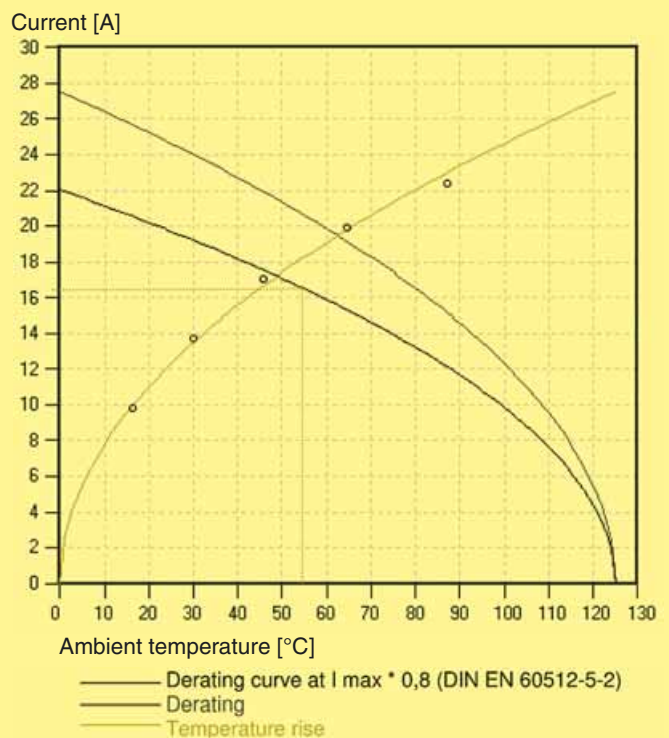

Derating diagram "power supply, 250 V"; 2 contacts loaded



### Overvoltage category

The overvoltage category is dependent on the mains voltage and the location at which the equipment is installed. It describes the maximum overvoltage resistance of a device in the event of a power supply system fault, e. g. in the event of a lightning strike.

The overvoltage category affects the dimensioning of components in that it determines the clearance air gap. Pursuant to the relevant standards, there are 4 overvoltage categories.

**Equipment for industrial use, all HARTING industrial connectors fall into Overvoltage Category III.**

Extract from DIN VDE 0110-1 and IEC 60664-1, Para. 2.2.2.1.1

**Equipment of overvoltage category III is equipment in fixed installations and for cases where the reliability and the availability of the equipment is subject to special requirements.**

**Note: Examples of such equipment are switches in the fixed installation and equipment for industrial use with permanent connection to the fixed installation.**

### Pollution degree

The dimensioning of operating equipment is dependent on environmental conditions. Any pollution or contamination may give rise to conductivity that, in combination with moisture, may affect the insulating properties of the surface on which it is deposited. The pollution degree influences the design of components in terms of the creepage distance.

The pollution degree is defined for exposed, unprotected insulation on the basis of environmental conditions.

**HARTING industrial connectors are designed as standard for Pollution Degree 3.**

**Pollution degree 3 in industrial, commercial and agricultural premises, unheated storage premises, workshops or boiler rooms, also for the electrical components of assembly or mounting equipment and machine tools.**

Extract from DIN VDE 0110-1 and IEC 60664-1, Para. 2.5.1

**Pollution degree 3: Conductive pollution occurs or dry non-conductive pollution occurs which becomes conductive due to condensation which is to be excepted.**

### Current carrying capacity

The current carrying capacity is determined in tests which are conducted on the basis of the DIN IEC 60512 part 3. The current carrying capacity is limited by the thermal properties of materials which are used for inserts as well as by the insulating materials. These components have a limiting temperature which should not be exceeded.

The relationship between the current, the temperature rise (loss at the contact resistance) and the ambient temperature of the connector is represented by a curve. On a linear co-ordinate system the current lies on the vertical line (ordinate) and the ambient temperature on the horizontal line (abscissa) which ends at the upper limiting temperature.

In another measurement the self-heating ( $\Delta t$ ) at different currents is determined.

At least 3 points are determined which are connected to a parabolic curve, the basic curve.

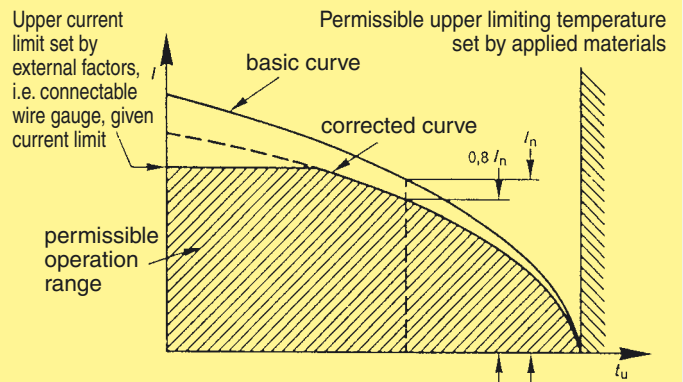

The corrected current carrying capacity curve is derived from this basic curve. The reasons for the correction are external factors that bring an additional limitation to the current carrying capacity, i.e. connectable wire gauge or an unequal dispersion of current.



Example of a current capacity curve

**Definition:** The rated current is the continuous, not interrupted current a connector can take when simultaneous power on all contacts is given, without exceeding the maximum temperature.

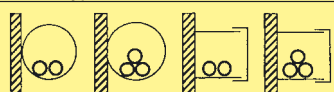
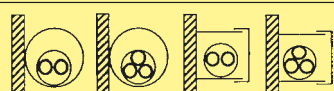
### Current carrying capacity of copper wires

Diameter [mm <sup>2</sup> ] of single wires in a three-phase system	0.75	1	1.5	2.5
Type of installation				
 B1 Wires in protective tubes and installation conduits	7.6	10.4	13.5	18.3
 B2 Cables and wires in protective tubes and installation conduits	–	9.6	12	16.5
 C Cables and wires at walls	–	11.7	15.2	21
 D Cables and wires on a bed	–	11.5	16.1	22

Depiction in accordance with DIN EN 60204 for PVC-insulated copper wires in an ambient temperature of + 40 °C under permanent operating conditions.

For different conditions and temperatures, installations, insulation materials or conductors the relevant corrections have to be carried out.



Han® PushPull S Power 4/0 connector for low voltage (48 V) applications

Identification	Part No.	Drawing	Dimensions in mm
<b>Connector set</b> incl. 4 turned crimp contacts (male), insulator body ( <b>grey</b> ), housing, cable gland	09 46 145 4400	<p>contact no.1, contact no.2, contact no.3, contact no.4, 20,15 maxi, 20 maxi, 41,5 maxi, sealing gland, washer and nut PG9</p>	
<b>Set of coding pins</b> To avoid accidental incorrect mating a coding system is required. The coding pins are inserted without loss of contacts.	09 46 840 0000		
<b>IP 67 / 65 protective cap with cord</b>	09 45 845 0001		

### Technical characteristics

Specifications	DIN VDE 0627, DIN VDE 0110, DIN EN 61 984
Working voltage	<b>48 V</b>
Working current per contact <sup>1)</sup>	<b>12 A @ 55 °C</b>
Rated impulse voltage	<b>1.5 kV (DIN EN 61 984)</b>
Overtoltage category	III (DIN VDE 0110 and IEC 60 664-1)
Pollution degree	3 (DIN VDE 0110 and IEC 60 664-1)
No. of current carrying contacts	<b>4</b>
Pre-leading PE contact	–
Contact resistance	max. 5 mΩ
Protection against contact	acc. to IEC DIN EN 60 529
Wire gauge	1.5 mm <sup>2</sup> (AWG 16) <sup>2)</sup> , stranded
Cable sheath diameter	6.9 - 8.6 mm
Protection class – mated	IP 67 / 65 (IEC DIN EN 60 529)
– unmated	IP 20 (IEC DIN EN 60 529)
Vibration and shock resistance	acc. to EN 50 155
Ambient temperature	– 40 ... + 70 °C
Mating security	Polarisation with polarisation nose, no mating of different connector variants possible
Coding	4 different possibilities, without losing contacts
Mating cycles	min. 750 <sup>2)</sup>
Strain relief	min. 100 N
Housing material	Polycarbonate and Polyamide, UL 94 V-0, UV resistant

Industrial interfaces

<sup>1)</sup> see derating diagram on page 11.54  
<sup>2)</sup> others on request



## Han® PushPull S Power 2/0 connector for (250 V) power supply

Identification	Part No.	Drawing	Dimensions in mm
<b>Connector set</b> incl. 3 turned crimp contacts (male) insulator body ( <b>black</b> ), housing, cable gland	09 46 145 3410		
<b>Set of coding pins</b> To avoid accidental incorrect mating a coding system is required. The coding pins are inserted without loss of contacts.	09 46 840 0000		
<b>IP 67 / 65 protective cap</b> with cord	09 45 845 0001		

## Technical characteristics

Specifications	DIN VDE 0627, DIN VDE 0110, DIN EN 61 984
Working voltage	<b>250 V</b>
Working current per contact <sup>1)</sup>	<b>16 A @ 55 °C</b>
Rated impulse voltage	<b>4.0 kV (DIN EN 61 984)</b>
Overvoltage category	III (DIN VDE 0110 and IEC 60 664-1)
Pollution degree	3 (DIN VDE 0110 and IEC 60 664-1)
No. of current carrying contacts	<b>2</b>
Pre-leading PE contact	<b>1</b>
Contact resistance	max. 5 mΩ
Protection against contact	acc. to IEC DIN EN 60 529
Wire gauge	1.5 mm <sup>2</sup> (AWG 16) <sup>2)</sup> , stranded
Cable sheath diameter	6.9 - 8.6 mm
Protection class – mated	IP 67 / 65 (IEC DIN EN 60 529)
– unmated	IP 20 (IEC DIN EN 60 529)
Vibration and shock resistance	acc. to EN 50 155
Ambient temperature	– 40 ... + 70 °C
Mating security	Polarisation with polarisation nose, no mating of different connector variants possible
Coding	4 different possibilities, without losing contacts
Mating cycles	min. 750 <sup>2)</sup>
Strain relief	min. 100 N
Housing material	Polycarbonate and Polyamide, UL 94 V-0, UV resistant

<sup>1)</sup> see derating diagram on page 11.54

<sup>2)</sup> others on request



Han® PushPull S Power 4/0 panel feed through for low voltage (48 V) applications

Identification	Part No.	Drawing	Dimensions in mm
<b>Panel feed through set</b> incl. 4 turned female contacts, insulator body ( <b>grey</b> ), receptacle housing  <b>for crimp termination</b>  with 90° solder pins (lead free acc. to RoHS) to be soldered onto a PCB, Pick-and-Place compatible, with Zero-Insertion-Force  with cage clamp termination	09 46 245 4400   09 46 245 4000  09 46 245 4001		
<b>Set of coding pins</b> To avoid accidental incorrect mating a coding system is required. The coding pins are inserted without loss of contacts.	09 46 840 0000		
<b>IP 67 / 65 protective cap</b> with cord	09 45 845 0004		

Technical characteristics

Specifications	DIN VDE 0627, DIN VDE 0110, DIN EN 61 984
Working voltage	<b>48 V</b>
Working current per contact <sup>1)</sup>	<b>12 A @ 55 °C</b>
Rated impulse voltage	<b>1.5 kV (DIN EN 61 984)</b>
Overtoltage category	III (DIN VDE 0110 and IEC 60 664-1)
Pollution degree	3 (DIN VDE 0110 and IEC 60 664-1)
No. of current carrying contacts	<b>4</b>
PE contact	–
Contact resistance	max. 5 mΩ
Protection against contact	acc. to IEC DIN EN 60 529
Wire gauge	– crimp 4 x 1.5 mm <sup>2</sup> (AWG 16) <sup>2)</sup> , stranded – cage clamp 4 x 1.5 mm <sup>2</sup> (AWG 16) <sup>2)</sup> , solid and stranded
Protection class	– mated IP 67 / 65 (IEC DIN EN 60 529) – unmated IP 20 (IEC DIN EN 60 529)
Vibration and shock resistance	acc. to EN 50 155
Ambient temperature	– 40 ... + 70 °C
Mating security	Polarisation with polarisation nose, no mating of different connector variants possible
Coding	4 different possibilities, without losing contacts
Mating cycles	min. 750 <sup>2)</sup>
Strain relief	min. 100 N
Housing material	Polycarbonate, UL 94 V-0, UV resistant

<sup>1)</sup> see derating diagram on page 11.54

<sup>2)</sup> others on request



## Han® PushPull S Power 2/0 panel feed through for (250 V) power supply

Identification	Part No.	Drawing	Dimensions in mm
<b>Panel feed through set</b> incl. 3 turned female contacts, insulator body ( <b>black</b> ), receptacle housing  for crimp termination	09 46 245 3410		
<b>Set of coding pins</b> To avoid accidental incorrect mating a coding system is required. The coding pins are inserted without loss of contacts.	09 46 840 0000		
<b>IP 67 / 65 protective cap</b> with cord	09 45 845 0004		

## Technical characteristics

Specifications	DIN VDE 0627, DIN VDE 0110, DIN EN 61 984
Working voltage	<b>250 V</b>
Working current per contact <sup>1)</sup>	<b>16 A @ 55 °C</b>
Rated impulse voltage	<b>4.0 kV (DIN EN 61 984)</b>
Overvoltage category	III (DIN VDE 0110 and IEC 60 664-1)
Pollution degree	3 (DIN VDE 0110 and IEC 60 664-1)
No. of current carrying contacts	<b>2</b>
PE contact	<b>1</b>
Contact resistance	max. 5 mΩ
Protection against contact	acc. to IEC DIN EN 60 529
Wire gauge	3 x 1.5 mm <sup>2</sup> (AWG 16) <sup>2)</sup> , stranded
Protection class	– mated IP 67 / 65 (IEC DIN EN 60 529) – unmated IP 20 (IEC DIN EN 60 529)
Vibration and shock resistance	acc. to EN 50 155
Ambient temperature	– 40 ... + 70 °C
Mating security	Polarisation with polarisation nose, no mating of different connector variants possible
Coding	4 different possibilities, without losing contacts
Mating cycles	min. 750 <sup>2)</sup>
Strain relief	min. 100 N
Housing material	Polycarbonate, UL 94 V-0, UV resistant

<sup>1)</sup> see derating diagram on page 11.54

<sup>2)</sup> others on request

Identification

Part No.

Han® PushPull Power  
8-indent crimping tool

09 46 800 0000



For wire gauges  
0.08 ... 4.0 mm<sup>2</sup>  
(AWG 28 ... 12).

Crimping tool depth adjustment gauge

Ø 1.02 mm

09 46 800 0002

For the fine adjustment of the crimping depth of the Han® PushPull Power 8-indent crimping tool.

Wire	Gauge
0.25 mm <sup>2</sup> ... 1.50 mm <sup>2</sup>	Ø 1.02 mm

Insertion tool

09 46 800 0099

Extraction tool

09 46 800 0098



For an easy insertion and extraction of the male and female crimp contacts into / out of the insulator body.

Crimp connection

A perfect crimp connection is gastight, therefore corrosion free and amounts to a cold weld of the parts being connected. For this reason, major features in achieving high quality crimp connections are the design of the contact crimping parts and of course the crimping tool itself. Wires to be connected must be carefully matched with the correct size of crimp contacts. If these basic requirements are met, users will be assured of highly reliable connections with low contact resistance and high resistance to corrosive attack.

The economic and technical advantages are:

- Constant contact resistance as a result of precisely repeated crimp connection quality
- Corrosion free connections as a result of cold weld action
- Pre-preparation of cable forms with crimp contacts fitted
- Optimum cost cable connection

Requirements for crimp connectors are laid down in DIN IEC 60 352-2, Amend. 2, as illustrated in the table.

Pull out force of stranded wire

The main criterion by which to judge the quality of a crimp connection is the retention force achieved by the wire conductor in the terminal section of the contact. DIN IEC 60 352, part 2, defines the extraction force in relation to the cross-section of the conductor. When fitted using HARTING crimping tools and subject to their utilization in an approved manner, our crimp connectors comply with the required extraction forces.

Crimping tools

Crimping tools (hand operated or automatic) are carefully designed to produce with high pressure forming parts a symmetrical connection of the crimping part of the contact and the wire being connected with the minimum increase in size at the connection point. The positioner automatically locates the crimp and wire at the correct point in the tool.

A ratchet in the tool performs 2 functions:

- ① It prevents insertion of the crimp into the tool for crimping before the jaws are fully open
- ② It prevents the tool being opened before the crimping action is completed

Identical, perfectly formed, connections can be produced using this crimping system.

Tensile strength of crimped connections

Conductor cross-section		Tensile strength
mm <sup>2</sup>	AWG	N
0.08	28	11
0.12	26	15
0.14		18
0.22	24	28
0.25		32
0.32	22	40
0.5	20	60
0.75		85
0.82	18	90
1.0		108
1.3	16	135
1.5		150
2.1	14	200
2.5		230
3.3	12	275
4.0		310

Extract from DIN IEC 60 352-2, Amend. 2, Table IV



Crimp-cross section  
HARTING crimp profile